

Microfabrication and Commercialization of a Chemical Gas Sensor

Steve Parshall

Spring 2006

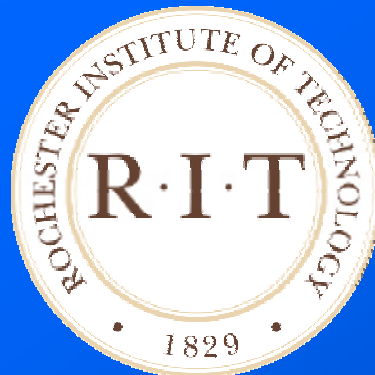

Motivation

- ? Typical fuel-cell and chromatography based devices for breath alcohol detection range from \$100-\$400+ per unit
- ? **Project Objective:** Design and fabricate a chemical gas sensor suitable for field breath-alcohol detection that is:
 - ? Portable
 - ? User-friendly
 - ? Reusable
 - ? Inexpensive



Sensor Design

- ? Designed using 6 inch platform to maximize real-estate
- ? Sensor consists of a single lithography step to define electrodes

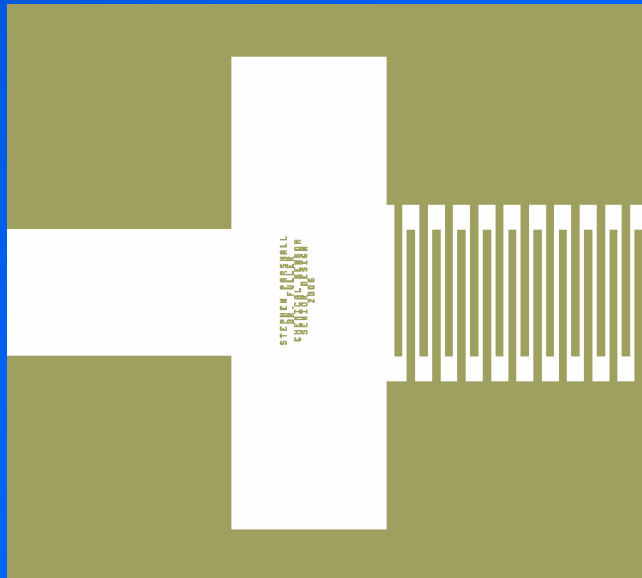

Figure 1: Mask defined interdigitated electrode spacing - 25 μm

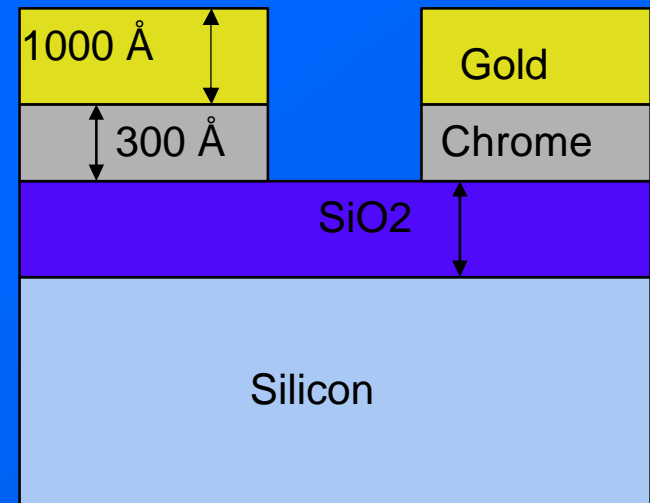

Figure 2: Device Cross-section

Final Device

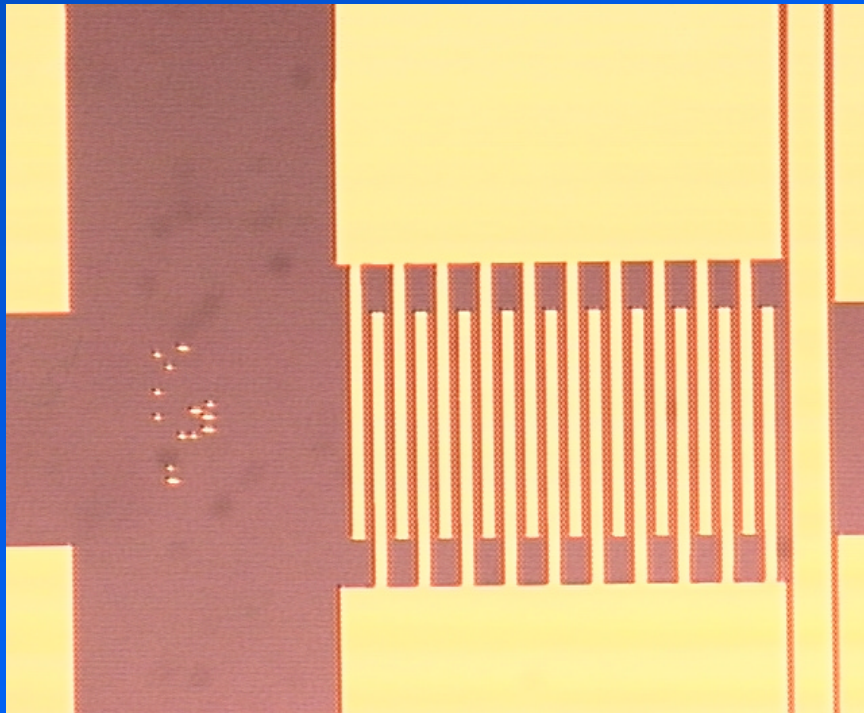

Figure 3: 5X Optical photo of completed sensor

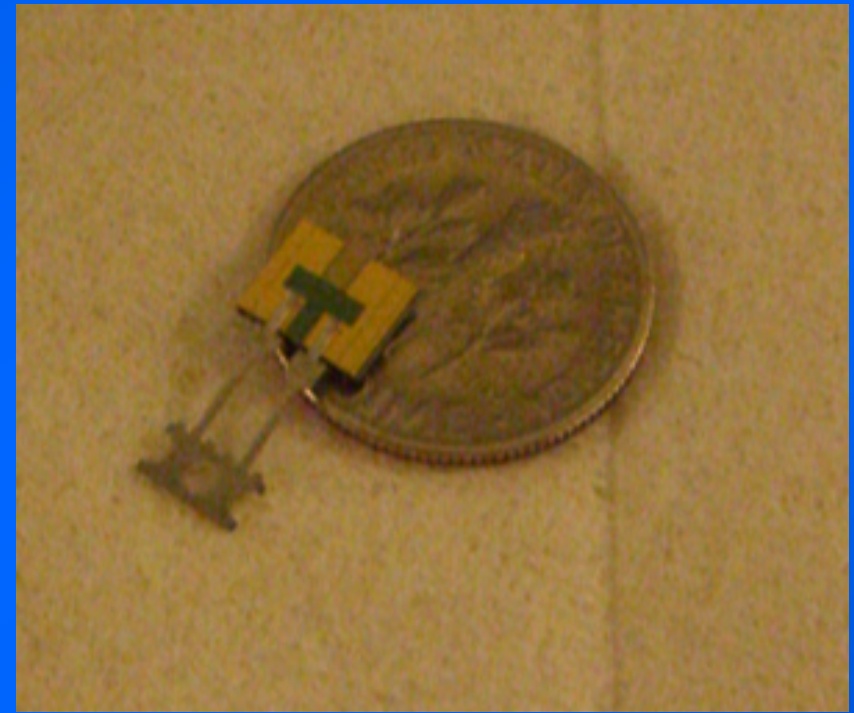
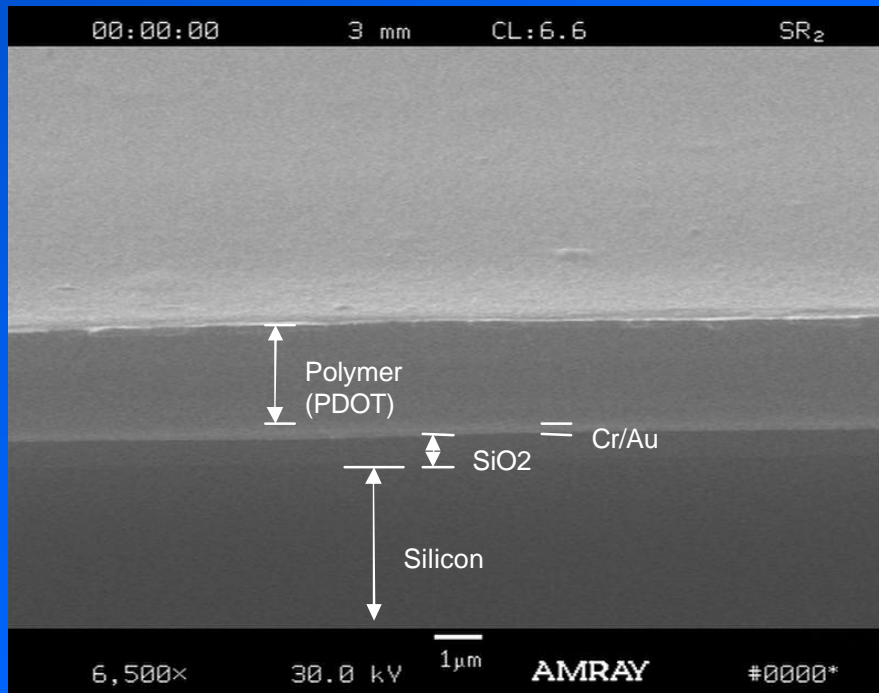

Figure 4: Completed sensor with chip pins attached

Polymer Application

- ? 2 μm of (3,4-polyethylenedioxythiophene-polystyrenesulfonate) PEDOT polymer is applied to interdigitated electrodes and cured at 100 $^{\circ}\text{C}$ for 30 minutes



SEM Cross-section and surface of sensor and polymer

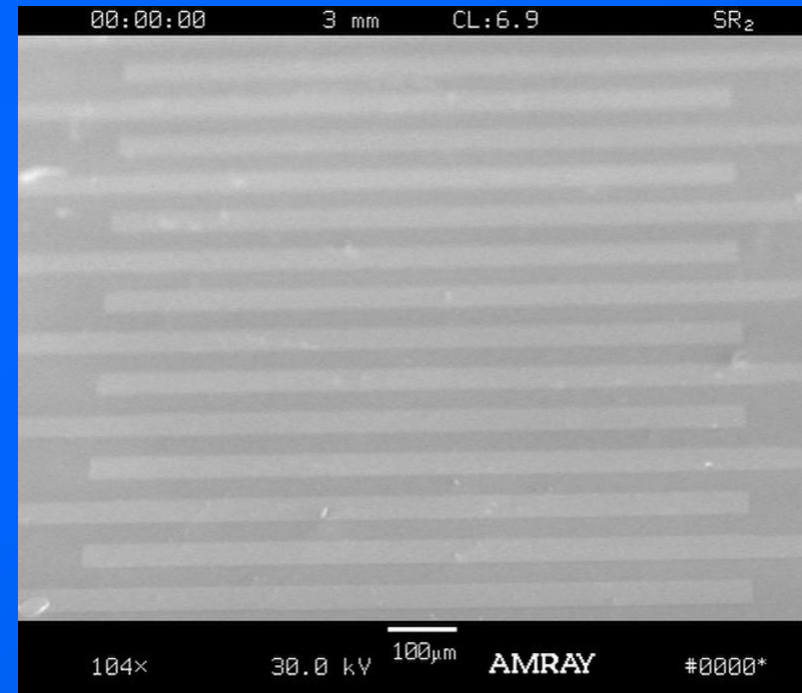

Aerial SEM image of sensor coated with polymer

Device Characterization

- ? PEDOT is a conductive polymer which upon exposure to ethanol vapors, will adsorb the ethanol causing the polymer to swell which results in a measurable change of resistance across the electrodes

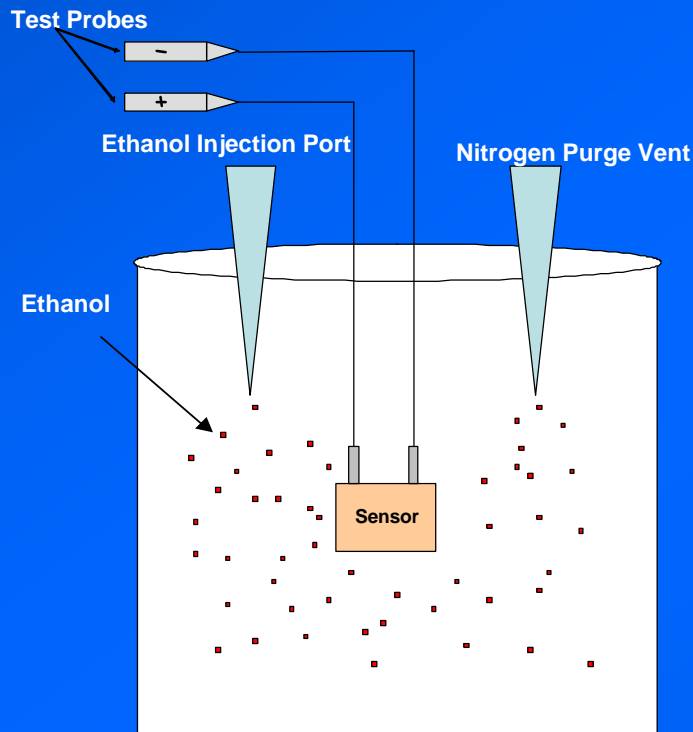

Experimental setup for introduction of ethanol to sensor under test

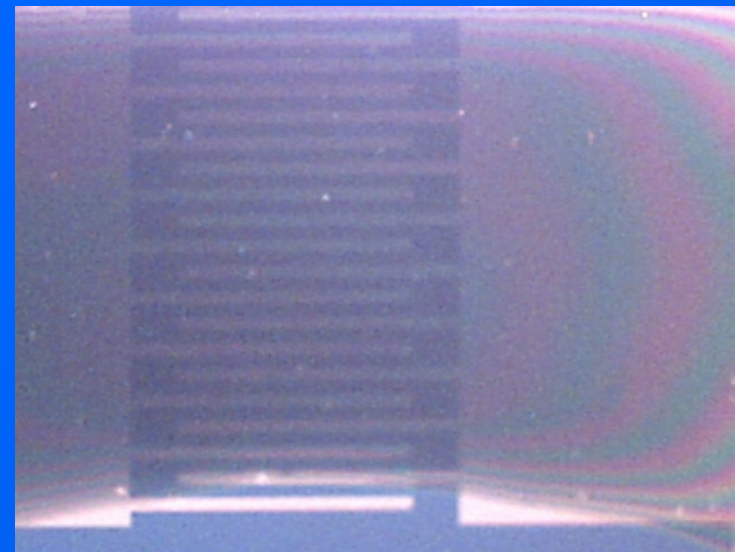

Optical photo of sensor coated with polymer

Baseline Testing

PEDOT-Coated Sensor

Chamber Volume: 250 mL

Injected Ethanol Concentration: 50 μ L

Temp: 27°C

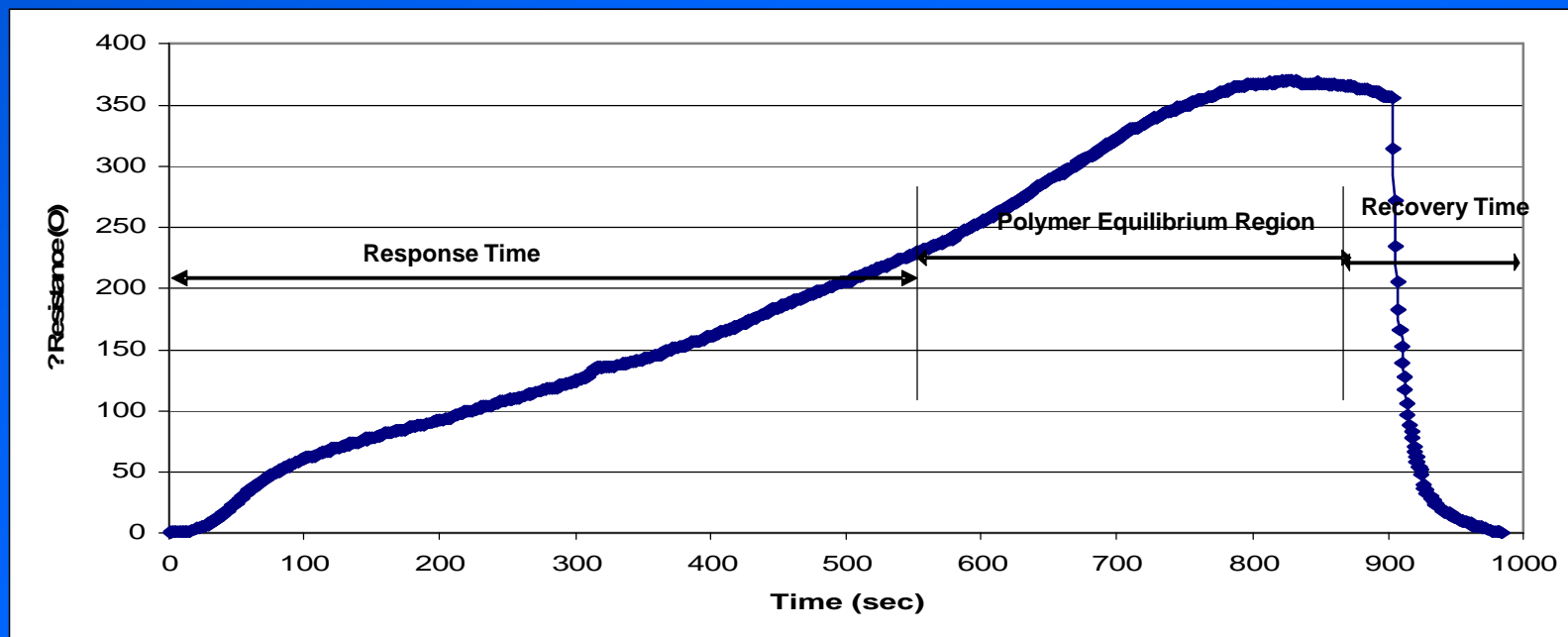

Ethanol injected into chamber



Sensor responds until polymer reaches saturation



Chamber is purged with Nitrogen

Baseline Sensor Response

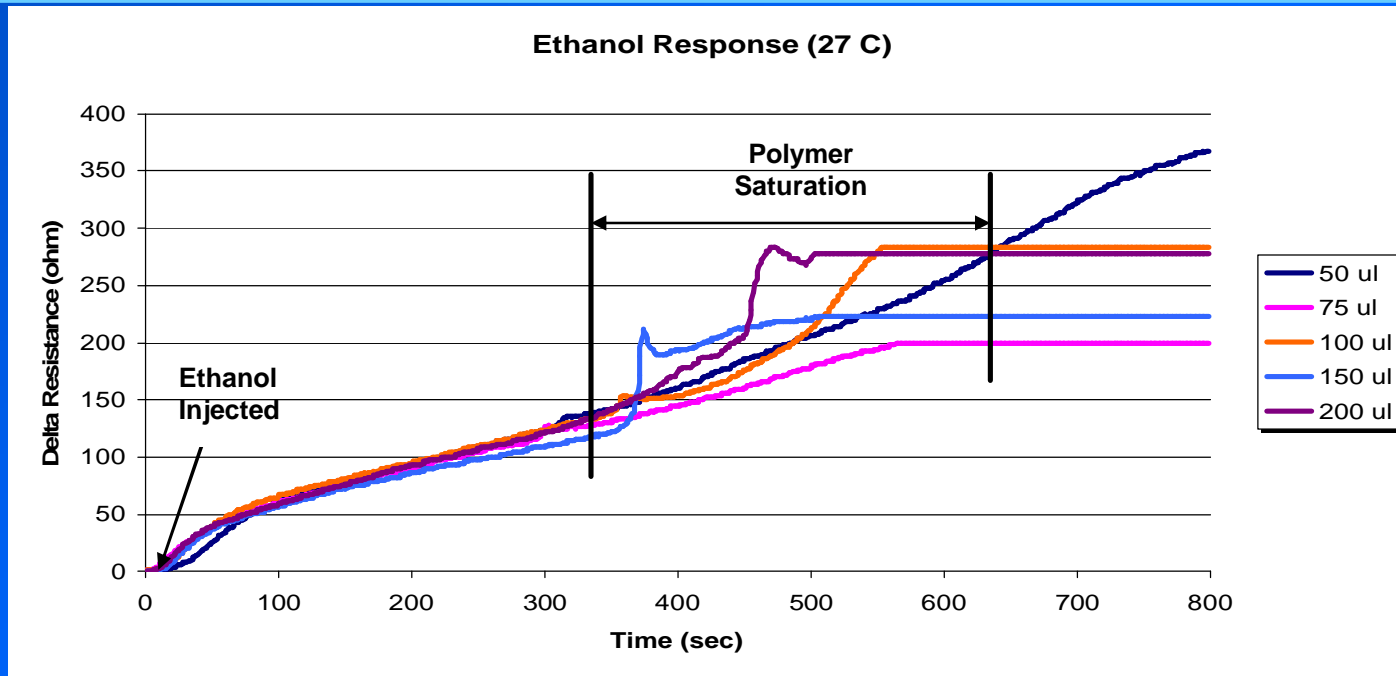

- ? Although the sensor responded to various concentrations of ethanol, the device would not be suitable for commercial breath alcohol detection applications:
 - ? Little or no distinction to increasing levels of ethanol concentrations
 - ? Slow response time (5+ minutes to reach equilibrium)
 - ? **Sensitivity of the device needs to be improved!!**

Polymer Modification

- ? To improve sensitivity, 100 mg of carbon (metalofullerenes As atomized) is added to 1 ml of PEDOT
- ? The carbon absorbs the ethanol vapors and allows the polymer to saturate and reach equilibrium much faster than the polymer alone, thus improving sensitivity

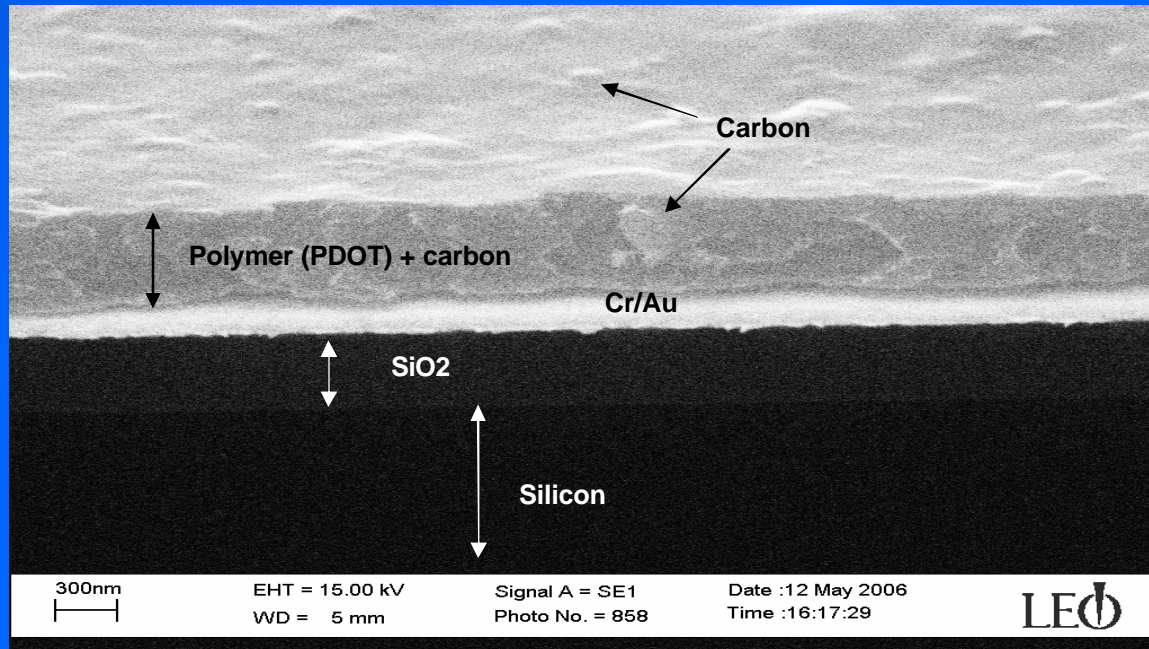

Ethanol Response

PEDOT-Coated Sensor with carbon

Chamber Volume: 250 mL

Injected Ethanol Concentration: 50 μ L

Temp: 27°C

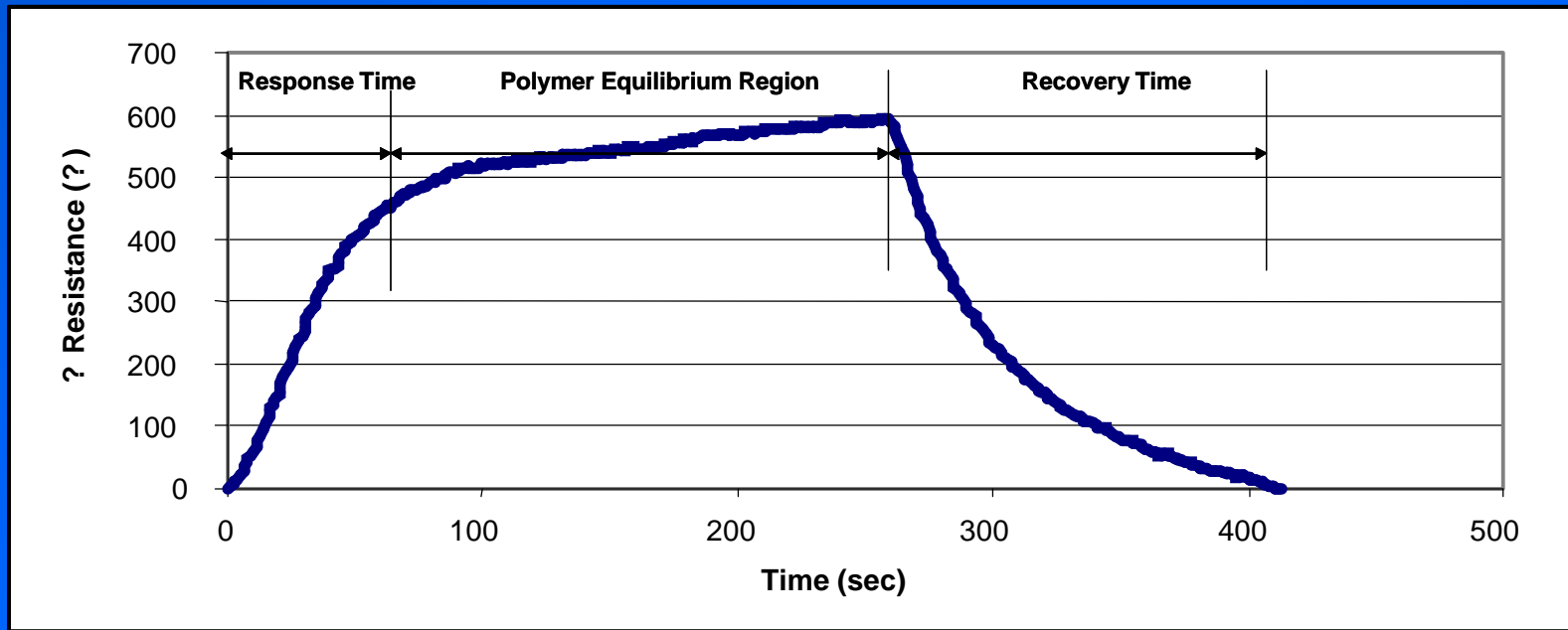

➔ Sensor response time improved to 60 seconds

Ethanol Response

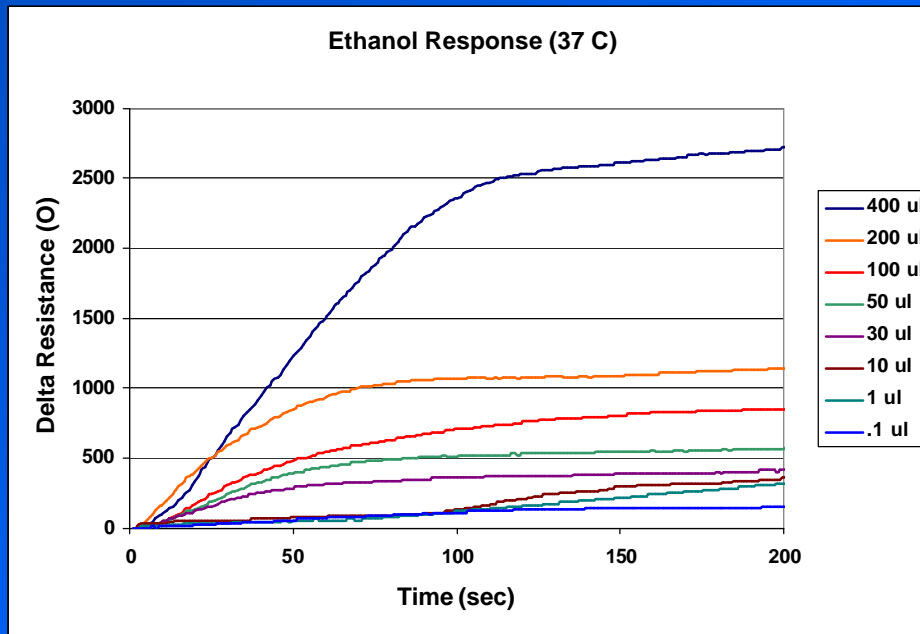

Response curve

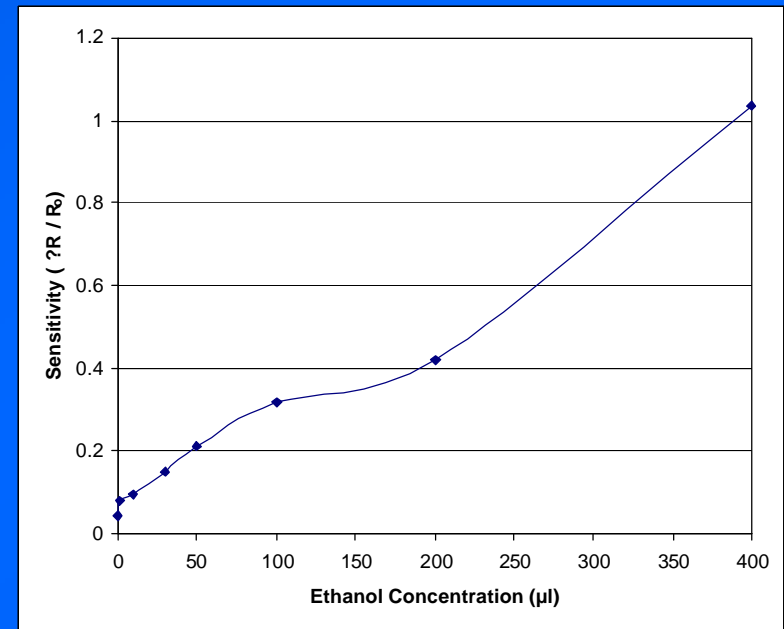

Sensitivity curve of sensor

- ? To simulate human breath, the test was performed at 37°C for ethanol concentrations ranging from 0.10 μl to 400 μl
 - ? The sensor easily distinguishes increasing concentrations of ethanol
 - ? Response time improved to 60 seconds

Commercial Application

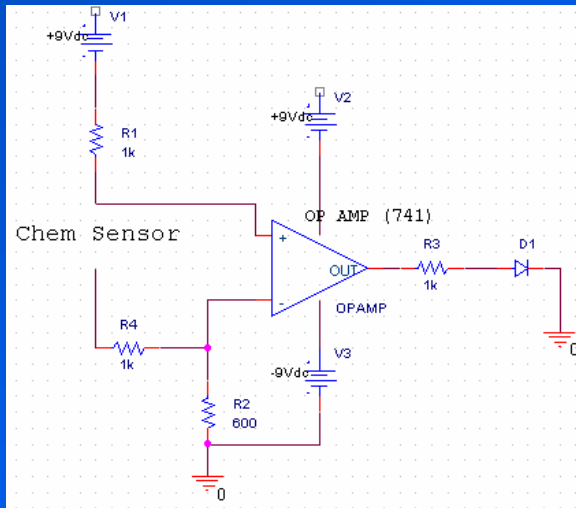

PPM	BAC
85	0.01
100	0.02
115	0.03
130	0.04
145	0.05
160	0.06
185	0.07
200	0.08
215	0.09
230	0.1

BAC = Blood Alcohol Concentration

BAC = wt. In gm of ethanol/100mL Blood

BAC = wt. In gm of ethanol/210L of Air

- ? The sensor exhibited a response time of 60 seconds with a recovery time of ~90 seconds even for the smallest tested ethanol concentration of $0.10 \mu\text{l}$
- ? $0.10 \mu\text{l}$ of ethanol in a 250 ml chamber is equivalent to a BAC level of 0.07*
- ? When packaged with an external feedback circuit, the sensor may be suitable for field breath-alcohol detection
- ? The proposed circuit operates on a 9V battery and would be lightweight and portable

* NY State maximum vehicle operation BAC level: 0.08

Project Summary

	Anticipated	Actual
Fabrication (cost)	\$944	\$1,120
Fabrication (time)	20 hours	44 hours
Materials (cost)	\$704	\$820
Testing (time)	20 hours	80+hours
Total (time)	40 hours	124 hours
Total (cost)	\$1,648	\$1,940
Sensors produced (5 wafer lot)	2860	2288
Cost per sensor	\$0.57	\$1.17

- ? Developed fabrication process for chemical gas sensor
- ? Successful characterization of polymer (PEDOT) response to ethanol
- ? Successful fabrication of low-cost, reusable chemical gas sensors
- ? Design of possible external feedback network which when packaged with the sensor may be suitable:
 - ? As a field breath alcohol screening device
 - ? For environmental monitoring applications



Acknowledgements

? SMFL Staff:

- ? Tom Grimsley: Administrative
- ? Sean O'Brian: Tool Certification

? Faculty

- ? Dr. Fuller: Principle Advisor
- ? Dr. K.S.V. Santhanam: Polymer Characterization
- ? Dr. Rommel: Project Guidance

? Students/Grad Students

- ? Jon Reese: SEM Images
- ? Tony Nguyen: SEM Images
- ? Kazuya Tokunaga
- ? Dave Pawlik

