

Universal Serial Bus Type-C Cable and Connector Specification

**Revision 1.0
August 11, 2014**

**Copyright © 2014, USB 3.0 Promoter Group:
Hewlett-Packard Company, Intel Corporation, Microsoft Corporation,
Renesas, STMicroelectronics, and Texas Instruments
All rights reserved.**

NOTE: Adopters may only use the USB Type-C cable and connector to implement USB or third party functionality as expressly described in this Specification; all other uses are prohibited.

LIMITED COPYRIGHT LICENSE: The USB 3.0 Promoters grant a conditional copyright license under the copyrights embodied in the USB Type-C Cable and Connector Specification to use and reproduce the Specification for the sole purpose of, and solely to the extent necessary for, evaluating whether to implement the Specification in products that would comply with the specification. Without limiting the foregoing, use of the Specification for the purpose of filing or modifying any patent application to target the Specification or USB compliant products is not authorized. Except for this express copyright license, no other rights or licenses are granted, including without limitation any patent licenses. In order to obtain any additional intellectual property licenses or licensing commitments associated with the Specification a party must execute the USB 3.0 Adopters Agreement. NOTE: By using the Specification, you accept these license terms on your own behalf and, in the case where you are doing this as an employee, on behalf of your employer.

INTELLECTUAL PROPERTY DISCLAIMER

THIS SPECIFICATION IS PROVIDED TO YOU "AS IS" WITH NO WARRANTIES WHATSOEVER, INCLUDING ANY WARRANTY OF MERCHANTABILITY, NON-INFRINGEMENT, OR FITNESS FOR ANY PARTICULAR PURPOSE. THE AUTHORS OF THIS SPECIFICATION DISCLAIM ALL LIABILITY, INCLUDING LIABILITY FOR INFRINGEMENT OF ANY PROPRIETARY RIGHTS, RELATING TO USE OR IMPLEMENTATION OF INFORMATION IN THIS SPECIFICATION. THE PROVISION OF THIS SPECIFICATION TO YOU DOES NOT PROVIDE YOU WITH ANY LICENSE, EXPRESS OR IMPLIED, BY ESTOPPEL OR OTHERWISE, TO ANY INTELLECTUAL PROPERTY RIGHTS.

All implementation examples and reference designs contained within this Specification are included as part of the limited patent license for those companies that execute the USB 3.0 Adopters Agreement.

All product names are trademarks, registered trademarks, or service marks of their respective owners.

CONTENTS

Specification Work Group Chairs / Specification Editors	10
Specification Work Group Contributors	10
Pre-Release Draft Industry Reviewing Companies That Provided Feedback.....	12
Revision History	12
1 Introduction	13
1.1 Purpose	13
1.2 Scope.....	13
1.3 Related Documents.....	14
1.4 Conventions.....	14
1.4.1 Precedence	14
1.4.2 Keywords	14
1.4.3 Numbering.....	15
1.5 Terms and Abbreviations	15
2 Overview	18
2.1 Introduction	18
2.2 USB Type-C Receptacles, Plugs and Cables	19
2.3 Configuration Process	20
2.3.1 DFP-to-UFP Attach/Detach Detection	21
2.3.2 Plug Orientation/Cable Twist Detection	21
2.3.3 Initial DFP-to-UFP (host-to-device) and Power Relationships Detection.....	21
2.3.4 USB Type-C VBUS Current Detection and Usage	22
2.3.5 USB PD Communication.....	22
2.3.6 Functional Extensions	22
2.4 VBUS.....	22
2.5 VCONN.....	23
2.6 Hubs	23
3 Mechanical.....	24
3.1 Overview	24
3.1.1 Compliant Connectors.....	24
3.1.2 Compliant Cable Assemblies	24
3.1.3 Compliant USB Type-C to Legacy Cable Assemblies	24
3.1.4 Compliant USB Type-C to Legacy Adapter Assemblies	25
3.2 USB Type-C Connector Mating Interfaces	26
3.2.1 Interface Definition.....	26
3.2.2 Reference Designs	42
3.2.3 Pin Assignments and Descriptions.....	49
3.3 Cable Construction and Wire Assignments.....	50
3.3.1 Cable Construction (Informative)	50
3.3.2 Wire Assignments	52
3.3.3 Wire Gauges and Cable Diameters (Informative)	53

3.4	Standard USB Type-C Cable Assemblies	55
3.4.1	USB Full-Featured Type-C Cable Assembly	55
3.4.2	USB 2.0 Type-C Cable Assembly.....	56
3.4.3	USB Type-C Captive Cable Assemblies	57
3.5	Legacy Cable Assemblies	57
3.5.1	USB Type-C to <i>USB 3.1</i> Standard-A Cable Assembly	58
3.5.2	USB Type-C to <i>USB 2.0</i> Standard-A Cable Assembly	59
3.5.3	USB Type-C to <i>USB 3.1</i> Standard-B Cable Assembly	60
3.5.4	USB Type-C to <i>USB 2.0</i> Standard-B Cable Assembly	61
3.5.5	USB Type-C to <i>USB 2.0</i> Mini-B Cable Assembly.....	62
3.5.6	USB Type-C to <i>USB 3.1</i> Micro-B Cable Assembly.....	63
3.5.7	USB Type-C to <i>USB 2.0</i> Micro-B Cable Assembly.....	65
3.6	Legacy Adapter Assemblies	65
3.6.1	USB Type-C to <i>USB 3.1</i> Standard-A Receptacle Adapter Assembly	66
3.6.2	USB Type-C to <i>USB 2.0</i> Micro-B Receptacle Adapter Assembly.....	67
3.7	Electrical Characteristics	69
3.7.1	Raw Cable (Informative)	69
3.7.2	Mated Connector (Normative)	70
3.7.3	USB Type-C to Type-C Passive Cable Assemblies (Normative)	74
3.7.4	USB Type-C to Legacy Cable Assemblies (Normative)	84
3.7.5	USB Type-C to USB Legacy Adapter Assemblies (Normative)	87
3.7.6	Shielding Effectiveness Requirements (Normative).....	89
3.7.7	DC Electrical Requirements (Normative)	90
3.8	Mechanical and Environmental Requirements (Normative).....	91
3.8.1	Mechanical Requirements.....	92
3.8.2	Environmental Requirements.....	93
3.9	Docking Applications (Informative)	95
3.10	Implementation Notes and Design Guides	96
3.10.1	EMC Management (Informative).....	96
3.10.2	Stacked and Side-by-Side Connector Physical Spacing (Informative)	98
3.10.3	Cable Mating Considerations (Informative).....	99
4	Functional.....	100
4.1	Signal Summary.....	100
4.2	Signal Pin Descriptions	100
4.2.1	SuperSpeed USB Pins	100
4.2.2	USB 2.0 Pins	101
4.2.3	Auxiliary Signal Pins.....	101
4.2.4	Power and Ground Pins	101
4.2.5	Configuration Pins	101
4.3	Sideband Use (SBU).....	101
4.4	Power and Ground.....	101
4.4.1	IR Drop.....	101
4.4.2	VBUS.....	102

4.4.3	VCONN.....	103
4.5	Configuration Channel (CC).....	104
4.5.1	Architectural Overview	104
4.5.2	CC Functional and Behavioral Requirements	115
4.5.3	USB Port Interoperability Behavior.....	131
4.6	Power.....	140
4.6.1	Power Requirements during USB Suspend.....	141
4.6.2	VBUS Power Provided Over a USB Type-C Cable	142
4.6.3	Supporting USB PD BFSK in Addition to USB PD BMC	144
4.7	USB Hubs	145
4.8	Chargers.....	145
4.8.1	DFP as a Power Source	145
4.8.2	Non-USB Charging Methods	146
4.8.3	Charging UFP	147
4.8.4	Charging a System with a Dead Battery	147
4.9	Electronically Marked Cables.....	147
4.10	VCONN-Powered Accessories.....	148
4.11	Parameter Values.....	149
4.11.1	Termination Parameters	149
4.11.2	Timing Parameters.....	151
4.11.3	Voltage Parameters.....	153
4.12	Summary of Ports by Product Type	155
5	Functional Extensions	157
5.1	Alternate Modes	157
5.1.1	Alternate Mode Architecture	157
5.1.2	Alternate Mode Requirements	157
5.1.3	Parameter Values	159
5.1.4	Example Alternate Mode – USB/PCIe Dock.....	160
5.2	Managed Active Cables.....	162
5.2.1	Requirements for Managed Active Cables that respond to SOP' and SOP"	162
5.2.2	Cable Message Structure	164
5.2.3	Modal Cable Management.....	164
A	Audio Adapter Accessory Mode	166
A.1.	Overview	166
A.2.	Detail	166
A.3.	Electrical Requirements	167
A.4.	Example Implementations	169
A.4.1.	Passive 3.5 mm to USB Type-C Adapter – Single Pole Detection Switch.....	169
A.4.2.	3.5 mm to USB Type-C Adapter Supporting 500 mA Charge-Through.....	169
B	Debug Accessory Mode	171

FIGURES

Figure 2-1 USB Type-C Receptacle Interface (Front View)	18
Figure 2-2 USB Full-Featured Type-C Plug Interface (Front View)	19
Figure 3-1 USB Type-C Receptacle Interface Dimensions.....	28
Figure 3-2 Reference Design USB Type-C Plug External EMC Spring Contact Zones	30
Figure 3-3 USB Full-Featured Type-C Plug Interface Dimensions	31
Figure 3-4 Reference Footprint for a USB Type-C Vertical Mount Receptacle (Informative).....	34
Figure 3-5 Reference Footprint for a USB Type-C Dual-Row SMT Right Angle Receptacle (Informative).....	35
Figure 3-6 Reference Footprint for a USB Type-C Hybrid Right-Angle Receptacle (Informative)	36
Figure 3-7 Reference Footprint for a USB Type-C Mid-Mount Dual-Row SMT Receptacle (Informative).....	37
Figure 3-8 Reference Footprint for a USB Type-C Mid-Mount Hybrid Receptacle (Informative).....	38
Figure 3-9 <i>USB 2.0</i> Type-C Plug Interface Dimensions	39
Figure 3-10 Reference Design of Receptacle Mid-Plate	42
Figure 3-11 Reference Design of the Retention Latch	43
Figure 3-12 Illustration of the Latch Soldered to the Paddle Card Ground.....	43
Figure 3-13 Reference Design of the USB Full-Featured Type-C Plug Internal EMC Spring	44
Figure 3-14 Reference Design of the <i>USB 2.0</i> Type-C Plug Internal EMC Spring	45
Figure 3-15 Reference Design of Internal EMC Pad.....	46
Figure 3-16 Reference Design of a USB Type-C Receptacle with External EMC Springs.....	47
Figure 3-17 Reference Design for a USB Full-Featured Type-C Plug Paddle Card.....	48
Figure 3-18 Illustration of a USB Full-Featured Type-C Cable Cross Section, a Coaxial Wire Example with VCONN.....	51
Figure 3-19 Illustration of a USB Full-Featured Type-C Cable Cross Section, a Coaxial Wire Example without VCONN.....	51
Figure 3-20 USB Full-Featured Type-C Standard Cable Assembly.....	55
Figure 3-21 USB Type-C to USB 3.1 Standard-A Cable Assembly	58
Figure 3-22 USB Type-C to <i>USB 2.0</i> Standard-A Cable Assembly	59
Figure 3-23 USB Type-C to <i>USB 3.1</i> Standard-B Cable Assembly.....	60
Figure 3-24 USB Type-C to <i>USB 2.0</i> Standard-B Cable Assembly.....	61
Figure 3-25 USB Type-C to <i>USB 2.0</i> Mini-B Cable Assembly	62
Figure 3-26 USB Type-C to <i>USB 3.1</i> Micro-B Cable Assembly	63
Figure 3-27 USB Type-C to <i>USB 2.0</i> Micro-B Cable Assembly	65
Figure 3-28 USB Type-C to <i>USB 3.1</i> Standard-A Receptacle Adapter Assembly	66
Figure 3-29 USB Type-C to <i>USB 2.0</i> Micro-B Receptacle Adapter Assembly	67
Figure 3-30 Illustration of USB Type-C Mated Connector.....	70
Figure 3-31 Recommended Impedance Limits of a USB Type-C Mated Connector.....	71
Figure 3-32 Recommended Ground Void Dimensions for USB Type-C Receptacle.....	71
Figure 3-33 Recommended Differential Insertion Loss Limits	72
Figure 3-34 Recommended Differential Return Loss Limits	72
Figure 3-35 Recommended Differential Crosstalk Limits between SuperSpeed Pairs.....	73
Figure 3-36 Recommended Differential Near-End and Far-End Crosstalk Limits between D+/D- Pair and SuperSpeed Pairs.....	73
Figure 3-37 Recommended Limits for Differential-to-Common-Mode Conversion.....	74
Figure 3-38 Illustration of Test Points for a Mated Cable Assembly	74
Figure 3-39 Recommended Differential Insertion Loss Requirement	75
Figure 3-40 Recommended Differential Return Loss Requirement.....	75
Figure 3-41 Recommended Differential Crosstalk Requirement	76
Figure 3-42 Recommended Differential Near-End and Far-End Crosstalk Requirement between USB D+/D- Pair and USB SuperSpeed Pair	76
Figure 3-43 Illustration of Insertion Loss Fit at Nyquist Frequency	77
Figure 3-44 Input Pulse Spectrum.....	78
Figure 3-45 IMR Limit as Function of ILfitatNq.....	79

Figure 3-46 IRL Limit as Function of ILfitatNq	80
Figure 3-47 Differential-to-Common-Mode Conversion Requirement.....	81
Figure 3-48 Requirement for Differential Coupling between CC and D+/D-.....	82
Figure 3-49 Requirement for Single-ended Coupling between VBUS and SBU_A/SBU_B and between VBUS and CC	82
Figure 3-50 Requirement for Differential Coupling between VBUS and D+/D-	83
Figure 3-51 Requirement for Single-Ended Coupling between SBU_A/SBU_B and CC, and for Differential Coupling between SBU_A/SBU_B and USB D+/D-	83
Figure 3-52 IMR Limit as Function of ILfitatNq for USB Type-C to Legacy Cable Assembly	87
Figure 3-53 IRL Limit as Function of ILfitatNq for USB Type-C to Legacy Cable Assembly	87
Figure 3-54 Cable Assembly Shielding Effectiveness Testing	90
Figure 3-55 Shielding Effectiveness Pass/Fail Criteria	90
Figure 3-56 LLCR Measurement Diagram.....	91
Figure 3-57 4-Axis Continuity Test	93
Figure 3-58 USB Type-C Cable Receptacle Flange Example.....	96
Figure 3-59 EMC Guidelines for Side Latch and Mid-plate.....	97
Figure 3-60 EMC Finger Connections to Plug Shell.....	97
Figure 3-61 EMC Pad Connections to Receptacle Shell	98
Figure 3-62 Examples of Connector Apertures.....	98
Figure 3-63 Recommended Minimum Spacing between Connectors.....	99
Figure 3-64 Recommended Minimum Plug Overmold Clearance	99
Figure 3-65 Cable Plug Overmold and an Angled Surface.....	99
Figure 4-1 Cable IR Drop.....	102
Figure 4-2 Cable IR Drop for powered cables.....	102
Figure 4-3 Logical Model for Data Bus Routing across USB Type-C-based Ports.....	105
Figure 4-4 Logical Model for USB Type-C-based Ports for the Direct Connect Device	106
Figure 4-5 Pull-Up/Pull-Down CC Model.....	107
Figure 4-6 Current Source/Pull-Down CC Model.....	107
Figure 4-7 DFP Functional Model for CC1 and CC2.....	110
Figure 4-8 DFP Functional Model Supporting USB PD Provider/Consumer	111
Figure 4-9 UFP Functional Model for CC1 and CC2.....	111
Figure 4-10 UFP Functional Model Supporting USB PD Consumer/Provider and VCONN_Swap.....	112
Figure 4-11 DRP Functional Model for CC1 and CC2.....	113
Figure 4-12 Connection State Diagram: DFP	115
Figure 4-13 Connection State Diagram: UFP.....	116
Figure 4-14 Connection State Diagram: UFP with Accessory Support.....	117
Figure 4-15 Connection State Diagram: DRP	118
Figure 4-16 Connection State Diagram: DRP with Accessory and Try.DFP Support	119
Figure 4-17 UFP Power Sub-States	128
Figure 4-18 DFP to UFP Functional Model.....	131
Figure 4-19 DFP to DRP Functional Model	132
Figure 4-20 DRP to UFP Functional Model	133
Figure 4-21 DRP to DRP Functional Model – CASE 1	134
Figure 4-22 DRP to DRP Functional Model – CASE 2	135
Figure 4-23 DFP to DFP Functional Model.....	136
Figure 4-24 UFP to UFP Functional Model.....	137
Figure 4-25 DFP to Legacy Device Port Functional Model.....	137
Figure 4-26 Legacy Host Port to UFP Functional Model.....	138
Figure 4-27 DRP to Legacy Device Port Functional Model	139
Figure 4-28 Legacy Host Port to DRP Functional Model	140
Figure 4-29 UFP Monitoring for Current in Pull-Up/Pull-Down CC Model.....	143
Figure 4-30 UFP Monitoring for Current in Current Source/Pull-Down CC Model.....	143
Figure 4-31 USB PD over CC Pins.....	144
Figure 4-32 USB PD BMC Signaling over CC.....	144
Figure 4-33 Example implementation of CC input protection in a UFP	145

Figure 4-34 Electronically Marked Cable with VCONN connected through the cable	148
Figure 4-35 Electronically Marked Cable with SOP' at both ends	148
Figure 4-36 DRP Timing.....	151
Figure 5-1 Pins Available for Reconfiguration over the Full-Featured Cable	158
Figure 5-2 Pins Available for Reconfiguration for Direct Connect Applications.....	158
Figure 5-3 USB/PCIe Dock Example	160
Figure 5-4 Managed Active Cable Plug SOP' and SOP" Assignment.....	163
Figure 5-5 Managed Active Cable.....	164
Figure A-1 Example Passive 3.5 mm to USB Type-C Adapter.....	169
Figure A-2 Example 3.5 mm to USB Type-C Adapter Supporting 500 mA Charge-Through	170

TABLES

Table 2-1 Summary of power supply options	23
Table 3-1 USB Type-C Standard Cable Assemblies	24
Table 3-2 USB Type-C Legacy Cable Assemblies.....	25
Table 3-3 USB Type-C Legacy Adapter Assemblies.....	25
Table 3-4 USB Type-C Receptacle Interface Pin Assignments	49
Table 3-5 USB Type-C Receptacle Interface Pin Assignments for USB 2.0-only Support	50
Table 3-6 USB Type-C Standard Cable Wire Assignments.....	52
Table 3-7 USB Type-C Cable Wire Assignments for Legacy Cables/Adapters	53
Table 3-8 Reference Wire Gauges for standard USB Type-C Cable Assemblies.....	54
Table 3-9 Reference Wire Gauges for USB Type-C to Legacy Cable Assemblies.....	54
Table 3-10 USB Full-Featured Type-C Standard Cable Assembly Wiring.....	56
Table 3-11 <i>USB 2.0</i> Type-C Standard Cable Assembly Wiring	57
Table 3-12 USB Type-C to <i>USB 3.1</i> Standard-A Cable Assembly Wiring.....	58
Table 3-13 USB Type-C to <i>USB 2.0</i> Standard-A Cable Assembly Wiring.....	59
Table 3-14 USB Type-C to <i>USB 3.1</i> Standard-B Cable Assembly Wiring.....	60
Table 3-15 USB Type-C to <i>USB 2.0</i> Standard-B Cable Assembly Wiring.....	61
Table 3-16 USB Type-C to <i>USB 2.0</i> Mini-B Cable Assembly Wiring	62
Table 3-17 USB Type-C to <i>USB 3.1</i> Micro-B Cable Assembly Wiring.....	64
Table 3-18 USB Type-C to <i>USB 2.0</i> Micro-B Cable Assembly Wiring.....	65
Table 3-19 USB Type-C to <i>USB 3.1</i> Standard-A Receptacle Adapter Assembly Wiring.....	67
Table 3-20 USB Type-C to <i>USB 2.0</i> Micro-B Receptacle Adapter Assembly Wiring.....	68
Table 3-21 Differential Insertion Loss Examples for USB SuperSpeed with Twisted Pair Construction	69
Table 3-22 Differential Insertion Loss Examples for USB SuperSpeed with Coaxial Construction.....	70
Table 3-23 Coupling Matrix for Low Speed Signals	81
Table 3-24 USB D+/D- Signal Integrity Requirements.....	84
Table 3-25 USB D+/D- Signal Integrity Requirements for USB Type-C to Legacy USB Cable Assemblies.....	85
Table 3-26 Design Targets for USB Type-C to <i>USB 3.1</i> Gen 2 Legacy Cable Assemblies (Informative)	85
Table 3-27 USB Type-C to <i>USB 3.1</i> Gen 2 Legacy Cable Assembly Signal Integrity Requirements (Normative)	86
Table 3-28 USB D+/D- Signal Integrity Requirements for USB Type-C to Legacy USB Adapter Assemblies (Normative).....	88
Table 3-29 Design Targets for USB Type-C to <i>USB 3.1</i> Standard-A Adapter Assemblies (Informative)	88
Table 3-30 USB Type-C to <i>USB 3.1</i> Standard-A Receptacle Adapter Assembly Signal Integrity Requirements (Normative).....	89
Table 3-31 Environmental Test Conditions	94
Table 3-32 Reference Materials.....	95
Table 4-1 USB Type-C List of Signals	100
Table 4-2 VCONN Source Characteristics.....	103

Table 4-3 VCONN Sink Characteristics.....	104
Table 4-4 USB Type-C-based Port Interoperability	106
Table 4-5 DFP Perspective	108
Table 4-6 DFP and UFP Behaviors by State	109
Table 4-7 USB PD Swapping Port Behavior Summary.....	114
Table 4-8 Mandatory and Optional States.....	130
Table 4-9 Precedence of power source usage	141
Table 4-10 DFP CC Termination (Rp) Requirements.....	149
Table 4-11 UFP CC Termination (Rd) Requirements.....	150
Table 4-12 Powered cable Termination Requirements.....	150
Table 4-13 UFP CC Termination Requirements.....	150
Table 4-14 SBU Termination Requirements	150
Table 4-15 VBUS and VCONN Timing Parameters.....	151
Table 4-16 DRP Timing Parameters	152
Table 4-17 CC Timing	152
Table 4-18 CC Voltages on DFP Side – Default USB.....	153
Table 4-19 CC Voltages on DFP Side – 1.5 A @ 5 V.....	153
Table 4-20 CC Voltages on DFP Side – 3.0 A @ 5 V.....	153
Table 4-21 Voltage on UFP CC Pins (Default USB Type-C Current only).....	153
Table 4-22 Voltage on UFP CC pins (Multiple DFP Current Advertisements).....	154
Table 4-23 Summary of Ports and Behaviors by Product Type	156
Table 5-1 USB Safe State Electrical Requirements	159
Table 5-2 USB Billboard Device Class Availability Following Alternate Mode Entry Failure	159
Table 5-3 Alternate Mode Signal Noise Ingression Requirements.....	159
Table 5-4 SOP' and SOP'' Timing.....	164
Table A-1 USB Type-C Analog Audio Pin Assignments.....	167
Table A-2 USB Type-C Analog Audio Pin Electrical Parameter Ratings.....	168

Specification Work Group Chairs / Specification Editors

Intel Corporation (USB 3.0 Promoter company)	Yun Ling – Mechanical WG co-chair, Mechanical Chapter Co-editor Bob Dunstan – Functional WG co-chair, Specification Co-author Brad Saunders – Plenary/Functional WG chair, Specification Co-author
Seagate	Alvin Cox, Mechanical WG co-chair, Mechanical Chapter Co-editor

Specification Work Group Contributors

Advanced-Connectek, Inc. (ACON)	Glen Chandler Jeff Chien Lee (Dick Lee) Ching Conrad Choy	Vicky Chuang Aven Kao Danny Liao Alan MacDougall	Alan Tsai Stephen Yang
Advanced Micro Devices	Steve Capezza	Walter Fry	Will Harris
Agilent Technologies, Inc.	James Choate		
Apple	Mahmoud Amini Sree Anantharaman Paul Baker Jason Chung David Conroy Bill Cornelius	William Ferry Zheng Gao Girault Jones Keong Kam Min Kim Chris Ligtenberg	Nathan Ng James Orr Keith Porthouse Sascha Tietz Colin Whitby-Strevens Dennis Yarak
Cypress Semiconductor	Mark Fu Rushil Kadakia	Anup Nayak Jagadeesan Raj	Sanjay Sancheti Subu Sankaran
Dell	Mohammed Hijazi David Meyers	Sean O'Neal Ernesto Ramirez	Thomas Voor
DisplayLink (UK) Ltd.	Pete Burgers	Richard Petrie	
Electronics Testing Center, Taiwan	Sophia Liu		
Foxconn	Asroc Chen Allen Cheng Jason Chou Edmond Choy Bob Hall	Chien-Ping Kao Ji Li Ann Liu Terry Little Steve Sedio	Pei Tsao AJ Yang Yuan Zhang Jessica Zheng Andy Yao
Foxlink/Cheng Uei Precision Industry Co., Ltd.	Robert Chen Sunny Chou Carrie Chuang Wen-Chuan Hsu Alex Hsue	Armando Lee Dennis Lee Justin Lin Tse Wu Ting	Steve Tsai Wen Yang Wiley Yang Junjie Yu
Google	Joshua Boilard Jim Guerin Jeffrey Hayashida Mark Hayter	Nithya Jagannathan Lawrence Lam Ingrid Lin Adam Rodriguez	David Schneider Ken Wu
Granite River Labs	Mike Engbretson	Johnson Tan	
Hewlett Packard (USB 3.0 Promoter company)	Alan Berkema Robin Castell	Michael Krause Jim Mann	Linden McClure Mike Pescetto

Hirose Electric Co., Ltd.	Jeremy Buan William MacKillop	Gourgen Oganessyan	Sid Tono
Intel Corporation (USB 3.0 Promoter company)	Dave Ackelson Mike Bell Kuan-Yu Chen Hengju Cheng Bob Dunstan Paul Durley Howard Heck Hao-Han Hsu Abdul (Rahman) Ismail	James Jaussi Luke Johnson Jerzy Kolinski Christine Krause Yun Ling Xiang Li Guobin Liu Steve McGowan	Chee Lim Nge Sridharan Ranganathan Brad Saunders Amit Srivastava Ron Swartz Karthi Vadivelu Rafal Wielicki
Japan Aviation Electronics Industry Ltd. (JAE)	Kenji Hagiwara Masaki Kimura Toshio Masumoto Joe Motojima Ron Muir Tadashi Okubo Kazuhiro Saito	Kimiaki Saito Yuichi Saito Mark Saubert Toshio Shimoyama Tatsuya Shioda Atsuo Tago Masaaki Takaku	Jussi Takaneva Tomohiko Tamada Kentaro Toda Kouhei Ueda Takakazu Usami Masahide Watanabe Youhei Yokoyama
JPC/Main Super Inc.	Sam Tseng	Ray Yang	
LeCroy Corporation	Daniel H. Jacobs		
Lenovo	Rob Bowser Tomoki Harada	Wei Lie	Howard Locker
Lotes Co., Ltd.	Ariel Delos Reyes Ernest Han Mark Ho	Regina Liu-Hwang Max Lo Charles Kaun	JinYi Tu Jason Yang
LSI Corporation	Dave Thompson		
Luxshare-ICT	Josue Castillo Daniel Chen Lisen Chen	CY Hsu Alan Kinningham John Lin	Stone Lin Pat Young
MegaChips Corporation	Alan Kobayashi		
Microchip (SMSC)	Josh Averyt Mark Bohm	Donald Perkins	Mohammed Rahman
Microsoft Corporation (USB 3.0 Promoter company)	Randy Aull Fred Bhesania Anthony Chen Marty Evans Vivek Gupta Robbie Harris	Robert Hollyer Kai Inha Jayson Kastens Andrea Keating Eric Lee	Ivan McCracken Toby Nixon Gene Obie Srivatsan Ravindran David Voth
MQP Electronics Ltd.	Sten Carlsen	Pat Crowe	
Nokia Corporation	Daniel Gratiot Pekka Leinonen	Samuli Makinen Pekka Talmola	Timo Toivola Panu Ylihaavisto
Renesas Electronics Corp. (USB 3.0 Promoter company)	Nobuo Furuya	Philip Leung	Kiichi Muto
Rohm Co., Ltd.	Mark Aaldering Kris Bahar Yusuke Kondo	Arun Kumar Vijendra Kuroodi Chris Lin	Takashi Sato Hiroshi Yoshimura

Samsung Electronics Co., Ltd.	Soondo Kim Woonki Kim	Jagoun Koo Cheolho Lee	Jun Bum Lee
Seagate	Alvin Cox Tony Priborsky	Tom Skaar	Dan Smith
STMicroelectronics (USB 3.0 Promoter company)	Nicolas Florenchie Joel Huloux	Christophe Lorin Patrizia Milazzo	Federico Musarra Pascal Legrand
Tektronics, Inc.	Randy White		
Texas Instruments (USB 3.0 Promoter company)	Jawaid Ahmad Richard Hubbard Scott Jackson Yoon Lee	Grant Ley Win Maung Lauren Moore Martin Patoka	Brian Quach Wes Ray Anwar Sadat Deric Waters
Tyco Electronics Corp. (TE Connectivity Ltd.)	Max Chao Robert E. Cid Kengo Ijiro Eiji Ikematsu Joan Leu Clark Li Mike Lockyer	Jim McGrath Takeshi Nakashima Luis A. Navarro Masako Saito Yoshiaki Sakuma Gavin Shih Hiroshi Shirai	Scott Shuey Hidenori Taguchi Bernard Vetten Ryan Yu Sjoerd Zwartkruis
VIA Technologies Inc.	Terrance Shih	Jay Tseng	Fong-Jim Wang

Pre-Release Draft Industry Reviewing Companies That Provided Feedback

Aces	Johnson Components & Equipment Co., Ltd.	Parade Technology
Allion Labs, Inc.	Joinsoon Electronics Mfg. Co. Ltd.	Pericom
Analogix Semiconductor	JST Mfg. Co., Ltd.	Qualcomm
BizLink International Corp.	Korea Electric Terminal	Semtech Corporation
Corning Optical Communications LLC	Marvell Semiconductor	Shenzhen Deren Electronic Co., Ltd.
Cypress Semiconductor	Motorola Mobility LLC	Silicon Image
Etron Technology Inc.	NEC	Simula Technology Corp.
Fairchild Semiconductor	Newnex Technology Corp.	SMK Corporation
Fujitsu Ltd.	NXP Semiconductors	Sony Corporation
Industrial Technology Research Institute (ITRI)	PalCONN/PalNova (Palpilot International Corp.)	Sumitomo Electric Industries Toshiba Corporation

Revision History

Revision	Date	Description
1.0	August 11, 2014	Initial Release

1 Introduction

With the continued success of the USB interface, there exists a need to adapt USB technology to serve newer computing platforms and devices as they trend toward smaller, thinner and lighter form-factors. Many of these newer platforms and devices are reaching a point where existing USB receptacles and plugs are inhibiting innovation, especially given the relatively large size and internal volume constraints of the Standard-A and Standard-B versions of USB connectors. Additionally, as platform usage models have evolved, usability and robustness requirements have advanced and the existing set of USB connectors were not originally designed for some of these newer requirements. This specification is to establish a new USB connector ecosystem that addresses the evolving needs of platforms and devices while retaining all of the functional benefits of USB that form the basis for this most popular of computing device interconnects.

1.1 Purpose

This specification defines the USB Type-C receptacles, plug and cables.

The USB Type-C Cable and Connector Specification is guided by the following principles:

- Enable new and exciting host and device form-factors where size, industrial design and style are important parameters
- Work seamlessly with existing USB host and device silicon solutions
- Enhance ease of use for connecting USB devices with a focus on minimizing user confusion for plug and cable orientation

The USB Type-C Cable and Connector Specification defines a new receptacle, plug, cable and detection mechanisms that are compatible with existing USB interface electrical and functional specifications. This specification covers the following aspects that are needed to produce and use this new USB cable/connector solution in newer platforms and devices, and that interoperate with existing platforms and devices:

- USB Type-C receptacles, including electro-mechanical definition and performance requirements
- USB Type-C plugs and cable assemblies, including electro-mechanical definition and performance requirements
- USB Type-C to legacy cable assemblies and adapters
- USB Type-C-based device detection and interface configuration, including support for legacy connections
- USB Power Delivery optimized for the USB Type-C connector

The USB Type-C Cable and Connector Specification defines a standardized mechanism that supports Alternate Modes, such as repurposing the connector for docking-specific applications.

1.2 Scope

This specification is intended as a supplement to the existing [USB 2.0](#), [USB 3.1](#) and [USB Power Delivery](#) specifications. It addresses only the elements required to implement and support the USB Type-C receptacles, plugs and cables.

Normative information is provided to allow interoperability of components designed to this specification. Informative information, when provided, may illustrate possible design implementations.

1.3 Related Documents

- USB 2.0** *Universal Serial Bus Revision 2.0 Specification*
This includes the entire document release package.
<http://www.usb.org/developers/docs>
- USB 3.1** *Universal Serial Bus Revision 3.1 Specification*
This includes the entire document release package.
<http://www.usb.org/developers/docs>
- USB PD** *USB Power Delivery Specification, Revision 2.0, August 11, 2014*
<http://www.usb.org/developers/docs>
- USB BB** *USB Billboard Device Class Specification, Revision 1.0, August 11, 2014*
<http://www.usb.org/developers/docs>
- USB BC** *Battery Charging Specification, Revision 1.2 (including errata and ECNs through March 15, 2012), March 15, 2012*
<http://www.usb.org/developers/docs>

1.4 Conventions

1.4.1 Precedence

If there is a conflict between text, figures, and tables, the precedence shall be tables, figures, and then text.

1.4.2 Keywords

The following keywords differentiate between the levels of requirements and options.

1.4.2.1 Informative

Informative is a keyword that describes information with this specification that intends to discuss and clarify requirements and features as opposed to mandating them.

1.4.2.2 May

May is a keyword that indicates a choice with no implied preference.

1.4.2.3 N/A

N/A is a keyword that indicates that a field or value is not applicable and has no defined value and shall not be checked or used by the recipient.

1.4.2.4 Normative

Normative is a keyword that describes features that are mandated by this specification.

1.4.2.5 Optional

Optional is a keyword that describes features not mandated by this specification. However, if an optional feature is implemented, the feature shall be implemented as defined by this specification (optional normative).

1.4.2.6 Reserved

Reserved is a keyword indicating reserved bits, bytes, words, fields, and code values that are set-aside for future standardization. Their use and interpretation may be specified by future extensions to this specification and, unless otherwise stated, shall not be utilized or adapted by vendor implementation. A reserved bit, byte, word, or field shall be set to zero by the

sender and shall be ignored by the receiver. Reserved field values shall not be sent by the sender and, if received, shall be ignored by the receiver.

1.4.2.7 Shall

Shall is a keyword indicating a mandatory (normative) requirement. Designers are mandated to implement all such requirements to ensure interoperability with other compliant Devices.

1.4.2.8 Should

Should is a keyword indicating flexibility of choice with a preferred alternative. Equivalent to the phrase “it is recommended that”.

1.4.3 Numbering

Numbers that are immediately followed by a lowercase “b” (e.g., 01b) are binary values. Numbers that are immediately followed by an uppercase “B” are byte values. Numbers that are immediately followed by a lowercase “h” (e.g., 3Ah) are hexadecimal values. Numbers not immediately followed by either a “b”, “B”, or “h” are decimal values.

1.5 Terms and Abbreviations

Term	Description
Accessory Mode	A reconfiguration of the connector based on the presence of Rd/Rd or Ra/Ra on CC1/CC2, respectively.
Active cable	An Electronically Marked Cable with additional electronics to condition the data path signals.
Alternate Mode	Operation defined by a vendor or standards organization that is associated with a SVID assigned by the USB-IF. Entry and exit into and from an Alternate Mode is controlled by the USB PD Structured VDM Enter Mode and Exit Mode commands.
Audio Adapter Accessory Mode	The Accessory Mode defined by the presence of Ra/Ra on CC1/CC2, respectively. See Appendix A.
BFSK	Binary Frequency Shift Keying used for USB PD communication over VBUS.
BMC	Biphase Mark Coding used for USB PD communication over the CC wire.
Captive cable	A cable that is terminated on one end with a USB Type-C plug and has a vendor-specific connect means (hardwired or custom detachable) on the opposite end.
CC	Configuration Channel (CC) used in the discovery, configuration and management of connections across a USB Type-C cable.
Debug Accessory Mode	The Accessory Mode defined by the presence of Rd/Rd on CC1/CC2, respectively. See Appendix B.
Default VBUS	VBUS voltage as defined by the USB 2.0 and USB 3.1 specifications. Note: where used, 5 V connotes the same meaning.

Term	Description
DFP	Downstream Facing Port, specifically associated with the flow of data in a USB connection. Typically the ports on a host or the ports on a hub to which devices are connected. In its initial state, the DFP sources VBUS and VCONN, and supports data. A charge-only DFP port only sources VBUS.
Direct connect	The host's DFP is connected directly with no USB hub in between, either via a cable or without (e.g., thumb drive), to the device's UFP.
DRP	The acronym used in this specification to refer to a USB data port that can operate as either a DFP or a UFP. The role that the port offers may be fixed to either a DFP or UFP or may alternate between the two port states. The port's role may be changed dynamically. Note: this term is not to be confused with the terminology in the USB Power Delivery specification where "dual-role port" refers to power roles.
DR_Swap	USB PD Data Role Swap.
Electronically Marked Cable	A USB Type-C cable that uses USB PD to provide the cable's characteristics.
Initiator	The port initiating a Vendor Defined Message. It is independent of the port's PD role (e.g., Provider, Consumer, Provider/Consumer, or Consumer/Provider). In most cases, the Initiator will be a host.
Passive cable	A cable that does not incorporate any electronics to condition the data path signals. A passive cable may or may not be electronically marked.
Powered cable	A cable with electronics in the plug that requires VCONN indicated by the presence of Ra between the VCONN pin and ground.
PR_Swap	USB PD Power Role Swap.
Responder	The port responding to the Initiator of a Vendor Defined Message (VDM). It is independent of the port's PD role (e.g., Provider, Consumer, Provider/Consumer, or Consumer/Provider). In most cases, the Responder will be a device.
SBU	Sideband Use.
SID	A Standard ID (SID) is a unique 16-bit value assigned by the USB-IF to identify an industry standard.
SVID	General reference to either a SID or a VID. Used by USB PD Structured VDMs when requesting SIDs and VIDs from a device.
Type-A	A general reference to all versions of USB "A" plugs and receptacles.
Type-B	A general reference to all versions of USB "B" plugs and receptacles.
Type-C Plug	A USB plug conforming to the mechanical and electrical requirements in this specification.
Type-C Port	The USB port associated to a USB Type-C receptacle. This includes the USB signaling, CC logic, multiplexers and other associated logic.
Type-C Receptacle	A USB receptacle conforming to the mechanical and electrical requirements of this specification.

Term	Description
UFP	Upstream Facing Port, specifically associated with the flow of data in a USB connection. The port on a device or a hub that connects to a host or the DFP of a hub. In its initial state, the UFP sinks VBUS and supports data.
USB 2.0 Type-C Cable	A USB Type-C to Type-C cable that only supports USB 2.0 data operation. This cable does not include USB 3.1 or SBU wires.
USB 2.0 Type-C Plug	A USB Type-C plug specifically designed to implement the USB 2.0 Type-C cable.
USB Full-Featured Type-C Cable	A USB Type-C to Type-C cable that supports USB 2.0 and USB 3.1 data operation. This cable includes SBU wires.
USB Full-Featured Type-C Plug	A USB Type-C plug specifically designed to implement the USB Full-Featured Type-C cable.
VCONN-powered accessory	An accessory that is powered from VCONN to operate in an Alternate Mode.
VCONN_Swap	USB PD VCONN Swap.
VDM	Vendor Defined Message as defined by the USB PD specification.
VID	A Vendor ID (VID) is a unique 16-bit value assigned by the USB-IF to identify a vendor.

2 Overview

2.1 Introduction

The USB Type-C receptacle, plug and cable provide a smaller, thinner and more robust alternative to existing [USB 3.1](#) interconnect (Standard and Micro USB cables and connectors). This new solution targets use in very thin platforms, ranging from ultra-thin notebook PCs down to smart phones where existing Standard-A and Micro-AB receptacles are deemed too large, difficult to use, or inadequately robust. Some key specific enhancements include:

- The USB Type-C receptacle may be used in very thin platforms as its total system height for the mounted receptacle is under 3 mm
- The USB Type-C plug enhances ease of use by being plug-able in either upside-up or upside-down directions
- The USB Type-C cable enhances ease of use by being plug-able in either direction between host and devices

While the USB Type-C interconnect no longer physically differentiates plugs on a cable by being an A-type or B-type, the USB interface still maintains such a host-to-device logical relationship. Determination of this host-to-device relationship is accomplished through a [Configuration Channel](#) (CC) that is connected through the cable. In addition, the [Configuration Channel](#) is used to set up and manage power and Alternate/Accessory Modes.

Using the [Configuration Channel](#), the USB Type-C interconnect defines a simplified 5 volt VBUS-based power delivery and charging solution that supplements what is already defined in the [USB 3.1 Specification](#). More advanced power delivery and battery charging features over the USB Type-C interconnect are based on the [USB Power Delivery Specification](#). As a product implementation improvement, the USB Type-C interconnect shifts the [USB PD](#) communication protocol from being communicated over VBUS to being delivered across the USB Type-C [Configuration Channel](#).

The USB Type-C receptacle, plug and cable designs are intended to support future USB functional extensions. As such, consideration was given to frequency scaling performance, pin-out arrangement and the configuration mechanisms when developing this solution. The definition of future USB functional extensions is not in the scope of this specification but rather will be provided in future releases of the base USB Specification, i.e., beyond the existing [USB 3.1 Specification](#).

Figure 2-1 illustrates the comprehensive functional signal plan for the USB Type-C receptacle, not all signals shown are required in all platforms or devices. As shown, the receptacle signal list functionally delivers both [USB 2.0](#) (D+ and D-) and [USB 3.1](#) (TX and RX pairs) data buses, USB power (VBUS) and ground (GND), [Configuration Channel](#) signals (CC1 and CC2), and two Sideband Use (SBU) signal pins. Multiple sets of USB data bus signal locations in this layout facilitate being able to functionally map the USB signals independent of plug orientation in the receptacle. For reference, the signal pins are labeled.

Figure 2-1 USB Type-C Receptacle Interface (Front View)

A1	A2	A3	A4	A5	A6	A7	A8	A9	A10	A11	A12
GND	TX1+	TX1-	VBUS	CC1	D+	D-	SBU1	VBUS	RX2-	RX2+	GND
GND	RX1+	RX1-	VBUS	SBU2	D-	D+	CC2	VBUS	TX2-	TX2+	GND
B12	B11	B10	B9	B8	B7	B6	B5	B4	B3	B2	B1

Figure 2-2 illustrates the comprehensive functional signal plan for the USB Type-C plug. Only one CC pin is connected through the cable to establish signal orientation and the other CC pin is repurposed as VCONN for powering electronics in the USB Type-C plug. Also, only one set of [USB 2.0](#) D+/D- wires are implemented in a USB Type-C cable. For USB Type-C cables that only intend to support [USB 2.0](#) functionality, the [USB 3.1](#) and SBU signals are not implemented.

Figure 2-2 USB Full-Featured Type-C Plug Interface (Front View)

A12	A11	A10	A9	A8	A7	A6	A5	A4	A3	A2	A1
GND	RX2+	RX2-	VBUS	SBU1	D-	D+	CC	VBUS	TX1-	TX1+	GND
GND	TX2+	TX2-	VBUS	VCONN			SBU2	VBUS	RX1-	RX1+	GND
B1	B2	B3	B4	B5	B6	B7	B8	B9	B10	B11	B12

2.2 USB Type-C Receptacles, Plugs and Cables

Cables and connectors, including USB Type-C to USB legacy cables and adapters, are explicitly defined within this specification. These are the only connectors and cables that are authorized by the licensing terms of this specification. All licensed cables and connectors are required to comply with the compliance and certification requirements that are developed and maintained by the [USB-IF](#).

The following USB Type-C receptacles and plugs are defined.

- USB Type-C receptacle for [USB 2.0](#), [USB 3.1](#) and full-featured platforms and devices
- USB Full-Featured Type-C plug
- [USB 2.0](#) Type-C plug

The following USB Type-C cables are defined.

- USB Full-Featured Type-C cable with a USB Full-Featured Type-C plug at both ends for [USB 3.1](#) and full-featured applications
- [USB 2.0](#) Type-C cable with a [USB 2.0](#) Type-C plug at both ends for [USB 2.0](#) applications
- Captive cable with either a USB Full-Featured Type-C plug or [USB 2.0](#) Type-C plug at one end

All of the defined USB Type-C receptacles, plugs and cables support USB charging applications, including support for the optional USB Type-C-specific implementation of the [USB Power Delivery Specification](#) (See Section 4.6.2.4).

All USB Full-Featured Type-C cables are electronically marked. [USB 2.0](#) Type-C cables may be electronically marked. See Section 4.9 for the requirements of Electronically Marked Cables.

The following USB Type-C to USB legacy cables and adapters are defined.

- [USB 3.1](#) Type-C to Legacy Host cable with a USB Full-Featured Type-C plug at one end and a [USB 3.1](#) Standard-A plug at the other end – *this cable supports use of a USB Type-C-based device with a legacy USB host*

- [USB 2.0](#) Type-C to Legacy Host cable with a [USB 2.0](#) Type-C plug at one end and a [USB 2.0](#) Standard-A plug at the other end – *this cable supports use of a USB Type-C-based device with a legacy [USB 2.0](#) host (primarily for mobile charging and sync applications)*
- [USB 3.1](#) Type-C to Legacy Device cable with a USB Full-Featured Type-C plug at one end and a [USB 3.1](#) Standard-B plug at the other end – *this cable supports use of legacy [USB 3.1](#) hubs and devices with a USB Type-C-based host*
- [USB 2.0](#) Type-C to Legacy Device cable with a [USB 2.0](#) Type-C plug at one end and a [USB 2.0](#) Standard-B plug at the other end – *this cable supports use of legacy [USB 2.0](#) hubs and devices with a USB Type-C-based host*
- [USB 2.0](#) Type-C to Legacy Mini Device cable with a [USB 2.0](#) Type-C plug at one end and a [USB 2.0](#) Mini-B plug at the other end – *this cable supports use of legacy devices with a [USB 2.0](#) Type-C-based host*
- [USB 3.1](#) Type-C to Legacy Micro Device cable with a USB Full-Featured Type-C plug at one end and a [USB 3.1](#) Micro-B plug at the other end – *this cable supports use of legacy [USB 3.1](#) hubs and devices with a USB Type-C-based host*
- [USB 2.0](#) Type-C to Legacy Micro Device cable with a [USB 2.0](#) Type-C plug at one end and a [USB 2.0](#) Micro-B plug at the other end – *this cable supports use of legacy [USB 2.0](#) hubs and devices with a USB Type-C-based host*
- [USB 3.1](#) Type-C to Legacy Standard-A adapter with a USB Full-Featured Type-C plug at one end and a [USB 3.1](#) Standard-A receptacle at the other end – *this adapter supports use of a legacy USB “thumb drive” style device or a legacy USB ThinCard device with a [USB 3.1](#) Type-C-based host*
- [USB 2.0](#) Type-C to Legacy Micro-B adapter with a [USB 2.0](#) Type-C plug at one end and a [USB 2.0](#) Micro-B receptacle at the other end – *this adapter supports charging a USB Type-C-based mobile device using a legacy USB Micro-B-based chargers, either captive cable-based or used in conjunction with a legacy [USB 2.0](#) Standard-A to Micro-B cable*

Implementations of USB Type-C to USB legacy cables may support [USB PD](#) BFSK-based communications by incorporating the required [USB PD](#) plug and cable requirements for the legacy connector end of the cable. USB Type-C to USB legacy adapters do not support [USB PD](#) BFSK-based communications.

USB Type-C receptacle to USB legacy adapters are explicitly not defined or allowed. Such adapters would allow many invalid and potentially unsafe cable connections to be constructed by users.

2.3 Configuration Process

The USB Type-C receptacle, plug and cable solution incorporates a configuration process to detect a downstream facing port to upstream facing port (DFP-to-UFP) connection for VBUS management and host-to-device connected relationship determination.

The configuration process is used for the following:

- DFP-to-UFP attach/detach detection
- Plug orientation/cable twist detection
- Initial DFP-to-UFP (host-to-device) and power relationships detection
- USB Type-C VBUS current detection and usage
- [USB PD](#) communication
- Discovery and configuration of functional extensions

Two pins on the USB Type-C receptacle, CC1 and CC2, are used for this purpose. Within a standard USB Type-C cable, only a single CC pin position within each plug of the cable is connected through the cable.

2.3.1 DFP-to-UFP Attach/Detach Detection

Initially, DFP-to-UFP attach is detected by a host or hub port (DFP) when one of the CC pins at its USB Type-C receptacle senses a specified resistance to GND. Subsequently, DFP-to-UFP detach is detected when the CC pin that was terminated at its USB Type-C receptacle is no longer terminated to GND.

Power is not applied to the USB Type-C host or hub receptacle (VBUS or VCONN) until the DFP detects the presence of an attached device (UFP) port. When a DFP-to-UFP attach is detected, the DFP is expected to enable power to the receptacle and proceed to normal USB operation with the attached device. When a DFP-to-UFP detach is detected, the port sourcing VBUS removes power.

2.3.2 Plug Orientation/Cable Twist Detection

The USB Type-C plug can be inserted into a receptacle in either one of two orientations, therefore the CC pins enable a method for detecting plug orientation in order to determine which SuperSpeed USB data signal pairs are functionally connected through the cable. This allows for signal routing, if needed, within a DFP or UFP to be established for a successful connection.

2.3.3 Initial DFP-to-UFP (host-to-device) and Power Relationships Detection

Unlike existing USB Type-A and Type-B receptacles and plugs, the mechanical characteristics of the USB Type-C receptacle and plug do not inherently establish the relationship of USB host and device ports. The CC pins on the receptacle also serve to establish an initial DFP-to-UFP and power relationships prior to the normal USB enumeration process.

For the purpose of defining how the CC pins are used to establish the initial DFP-to-UFP relationship, the following port behavior modes are defined.

1. Host-only – for this mode, the port exclusively behaves as a DFP
2. Device-only – for this mode, the port exclusively behaves as a UFP
3. Dual-role – for this mode, the port can behave either as a DFP or UFP

The host-only and device-only ports behaviorally map to traditional USB host ports and USB device ports, respectively. When a host-only port is attached to a device-only port, the behavior from the user's perspective follows the traditional USB host-to-device port model. However, the USB Type-C connector solution does not physically prevent host-to-host or device-to-device connections. In this case, the resulting host-to-host or device-to-device connection results in a safe but non-functional situation.

Initially, the DFP sources VBUS and the UFP sinks VBUS. [USB PD](#) may then be used to independently swap both the data and power roles of the ports.

USB hubs have two types of ports, a single UFP that is connected up to a host or another hub and one or more DFPs for connecting other devices.

A port that supports dual-role operation by being able to shift to the appropriate connected mode when attached to either a host-only or device-only port is a DRP. In the special case of a DRP being attached to another DRP, an initialization protocol across the CC pins is used to establish the initial host-to-device relationship, and in this case, the determination of which is DFP or UFP is random from the user's perspective.

Two methods are defined to allow a USB Type-C DRP to functionally swap data roles, one managed using [USB PD](#) DR_Swap and the other emulating a disconnect/reconnect sequence (see Figure 4-16). As an alternative to role swapping, a USB Type-C DRP may provide useful functionality by when operating as a host, exposing a CDC/network (preferably TCP/IP) stack or when operating as a device, exposing a CDC/network interface.

2.3.4 USB Type-C Vbus Current Detection and Usage

With the USB Type-C connector solution, a DFP (host or downstream hub port) may implement higher source current over VBUS to enable faster charging of mobile devices or powering devices that require more current than is specified in the [USB 3.1 Specification](#). All USB host and hub ports advertise via the CC pins the level of current that is presently available. The USB device port is required to manage its load to stay within the current level offered by the host or hub, including dynamically scaling back the load if the host or hub port changes its advertisement to a lower level as indicated over the CC pins.

Three current levels at default VBUS are defined by [USB Type-C Current](#):

- Default values as defined by a USB Specification
- 1.5 A
- 3.0 A

The higher [USB Type-C Current](#) levels that can be advertised allows hosts and devices that do not implement [USB PD](#) to take advantage of higher charging current.

2.3.5 USB PD Communication

[USB Power Delivery](#) is a feature on products (hosts, hubs and devices). [USB PD](#) communications is used to:

- Establish power contracts that allow voltage and current outside that defined by the [USB 2.0](#) and [USB 3.1](#) specifications.
- Change the port sourcing VBUS.
- Change the port sourcing VCONN.
- Swap DFP and UFP roles.
- Communicate with cables.

The USB Type-C connector solution provides a new path for [USB PD](#) communications. Rather than superimposing a Binary Frequency Shift Keying (BFSK) on VBUS, the [USB PD](#) Bi-phase Mark Coded (BMC) communications are carried on the CC wire. In USB Type-C to legacy applications, the use of [USB PD](#) BFSK is allowed.

2.3.6 Functional Extensions

Functional extensions (see Chapter 5) are enabled via a communications channel across CC using methods defined by the [USB Power Delivery Specification](#).

2.4 VBUS

VBUS provides a path to deliver power between a host and a device, and between a charger and a host/device. A simplified high-current supply capability is defined for hosts and chargers that optionally support current levels beyond the [USB 2.0](#) and [USB 3.1](#) specifications. The [USB Power Delivery Specification](#) is supported.

Table 2-1 summarizes the power supply options available from the perspective of a device with the USB Type-C connector. Not all options will be available to the device from all host

or hub ports – only the first two listed options are mandated by the base USB specifications and form the basis of [USB Type-C Current](#) at the Default USB Power level.

Table 2-1 Summary of power supply options

Mode of Operation	Nominal Voltage	Maximum Current	Notes
USB 2.0	5 V	500 mA	Default Current, based on definitions in the base specifications
USB 3.1	5 V	900 mA	
USB BC 1.2	5 V	Up to 1.5 A	Legacy charging
USB Type-C Current @ 1.5 A	5 V	1.5 A	Supports higher power devices
USB Type-C Current @ 3.0 A	5 V	3 A	Supports higher power devices
USB PD	Configurable up to 20 V	Configurable up to 5 A	Directional control and power level management

The USB Type-C receptacle is specified for current capability of 5 A whereas standard USB Type-C cable assemblies are rated for 3 A. The higher rating of the receptacle enables systems to deliver more power over directly attached docking solutions or using appropriately designed chargers with captive cables when implementing [USB PD](#). Also, USB Type-C cable assemblies designed for [USB PD](#) and appropriately identified via electronic marking are allowed to support up to 5 A.

2.5 VCONN

Once the connection between host and device is established, the CC pin (CC1 or CC2) in the receptacle that is not connected via the CC wire through the standard cable is repurposed to source VCONN to power circuits in the plug needed to implement Electronically Marked Cables (see Section 4.9). Initially, the DFP sources VCONN and the source may be swapped using [USB PD](#) VCONN_Swap.

Electronically marked cables may use VBUS instead of VCONN as VBUS is available across the cable. VCONN functionally differs from VBUS in that it is isolated from the other end of the cable. VCONN is independent of VBUS and, unlike VBUS which can use [USB PD](#) to support higher voltages, VCONN voltage is fixed at 5 V.

2.6 Hubs

USB hubs implemented with USB Type-C receptacles are required to clearly identify the upstream facing port. This requirement is needed because a user can no longer know which port on a hub is the upstream facing port and which ports are the downstream facing ports by the type of receptacles that are exposed, i.e., USB Type-B is the upstream facing port and USB Type-A is a downstream facing port.

3 Mechanical

3.1 Overview

3.1.1 Compliant Connectors

The USB Type-C specification defines the following standard connectors:

- USB Type-C receptacle
- USB Full-Featured Type-C plug
- USB 2.0 Type-C plug

3.1.2 Compliant Cable Assemblies

Table 3-1 summarizes the USB Type-C standard cable assemblies along with the primary differentiating characteristics. The cable lengths listed in the table are informative and represents the practical length based on cable performance requirements. All cables that are either full-featured and/or are rated at more than 3 A current are [Electronically Marked Cables](#).

Table 3-1 USB Type-C Standard Cable Assemblies

Cable Ref	Plug 1	Plug 2	USB Version	Cable Length	Current Rating	USB Power Delivery (BMC)	USB Type-C Electronically Marked
CC2-3	C	C	USB 2.0	≤ 4 m	3 A	Supported	Optional
CC2-5					5 A		Required
CC3G1-3	C	C	USB 3.1 Gen1	≤ 2 m	3 A	Supported	Required
CC3G1-5					5 A		
CC3G2-3	C	C	USB 3.1 Gen2	≤ 1 m	3 A	Supported	Required
CC3G2-5					5 A		

USB Type-C products are also allowed to have a captive cable. See Section 3.4.3.

3.1.3 Compliant USB Type-C to Legacy Cable Assemblies

Table 3-2 summarizes the USB Type-C legacy cable assemblies along with the primary differentiating characteristics. The cable lengths listed in the table are informative and represents the practical length based on cable performance requirements. All cables that are either [USB 3.1](#) Gen2 and/or are rated at more than 3 A current are [Electronically Marked Cables](#). [USB 3.1](#) Type-C legacy cables assemblies that only offer performance up to [USB 3.1](#) Gen1 are not allowed by this specification.

Table 3-2 USB Type-C Legacy Cable Assemblies

Cable Ref	Plug 1	Plug 2	USB Version	Cable Length	Current Rating	USB Power Delivery (BFSK) ¹	USB Type-C Electronically Marked
AC2-1.5	A	C ²	USB 2.0	≤ 4 m	1.5 A	Optional	N/A
AC2-5					5 A	Supported	Required
AC3G2-1.5	A	C ²	USB 3.1 Gen2	≤ 1 m	1.5 A	Optional	N/A
AC3G2-5					5 A	Supported	Required
CB2-1.5	C ³	B	USB 2.0	≤ 4 m	1.5 A	Optional	Optional
CB2-5					5 A	Supported	Required
CB3G2-1.5	C ³	B	USB 3.1 Gen2	≤ 1 m	1.5 A	Optional	Required
CB3G2-5					5 A	Supported	
CmB2	C ³	Mini-B	USB 2.0	≤ 4 m	500 mA	N/A	N/A
CuB2-1.5	C ³	Micro-B	USB 2.0	≤ 2 m	1.5 A	Optional	Optional
CuB2-3					3 A	Supported	
CuB3G2-1.5	C ³	Micro-B	USB 3.1 Gen2	≤ 1 m	1.5 A	Optional	Required
CuB3G2-3					3 A	Supported	

Notes:

1. This capability only functions with USB Type-C products that incorporate [USB PD](#) BFSK support in addition to [USB PD](#) BMC – support for [USB PD](#) BFSK will not likely be common for products based on USB Type-C. For all legacy adapter cables that will be certified for [USB PD](#) BFSK usage, the legacy plug is required to be the [USB PD](#) version of the plug and appropriate [USB PD](#) cable marking is required. See Section 4.6.3.
2. USB Type-C plugs associated with the “B” end of a legacy adapter cable are required to have Rp termination incorporated into the plug assembly – see Section 4.5.3.2.2.
3. USB Type-C plugs associated with the “A” end of a legacy adapter cable are required to have Rd termination incorporated into the plug assembly – see Section 4.5.3.2.1.

3.1.4 Compliant USB Type-C to Legacy Adapter Assemblies

Table 3-3 summarizes the USB Type-C legacy adapter assemblies along with the primary differentiating characteristics. The cable lengths listed in the table are informative and represents the practical length based on cable performance requirements.

Table 3-3 USB Type-C Legacy Adapter Assemblies

Adapter Ref	Plug	Receptacle	USB Version	Cable Length	Current Rating	USB Power Delivery (BFSK)	USB Type-C Electronically Marked
CuBR2-1.5	C ¹	Micro-B	USB 2.0	≤ 0.15 m	1.5 A	N/A	N/A
CAR3G1-1.5	C ²	A	USB 3.1 Gen1	≤ 0.15 m	1.5 A	N/A	Optional

Notes:

1. USB Type-C plugs associated with the “B” end of a legacy adapter are required to have Rp termination incorporated into the plug assembly – see Section 4.5.3.2.2.
2. USB Type-C plugs associated with the “A” end of a legacy adapter are required to have Rd termination incorporated into the plug assembly – see Section 4.5.3.2.1.

3.2 USB Type-C Connector Mating Interfaces

This section defines the connector mating interfaces, including the connector interface drawings, pin assignments and descriptions.

3.2.1 Interface Definition

Figure 3-1 and Figure 3-3 show, respectively, the USB Type-C receptacle and USB Full-Featured Type-C plug interface dimensions. Figure 3-9 shows the [USB 2.0](#) Type-C plug interface dimensions. The dimensions that govern the mating interoperability are specified. All the REF dimensions are provided for reference only, not hard requirements.

Key features, configuration options, and design areas that need attention:

1. Figure 3-1 shows a vertical-mount receptacle. Other PCB mounting types such as right-angle mount and mid-mount are allowed.
2. A mid-plate is required between the top and bottom signals inside the receptacle tongue to manage crosstalk in full-featured applications. The mid-plate shall be connected to the PCB ground with at least two grounding points. A reference design of the mid-plate is provided in Section 3.2.2.1.
3. Retention of the cable assembly in the receptacle is achieved by the side-latches in the plug and features on the sides of the receptacle tongue. Side latches are required for all plugs except plugs used for docking with no cable attached. Side latches shall be connected to ground inside the plug. A reference design of the side latches is provided in Section 3.2.2.2 along with its grounding scheme. Docking applications may not have side latches, requiring special consideration regarding EMC (Electromagnetic Compatibility).
4. The EMC shielding springs are required inside the cable plug. The shielding spring shall be connected to the plug shell. Section 3.2.2.3 shows reference designs of the EMC spring.
5. Shorting of any signal or power contact spring to the plug metal shell is not allowed. The spring in the deflected state should not touch the plug shell. An isolation layer (e.g., Kapton tape placed on the plug shell) is recommended to prevent accidental shorting due to plug shell deformation.
6. The USB Type-C receptacle shall provide an EMC ground return path through one of the following options:
 - Fingers in the receptacle outer shell
 - Internal EMC pads
 - Both external fingers in the shell and internal EMC pads

If fingers in the receptacle outer shell are used, then the mated plug for receptacle springs shall make contact within the zones defined in Figure 3-2. A minimum of six separate contact points are required. Additional fingers and points of contact are allowed. See Section 3.2.2.4 for a reference design of the shell fingers.

If internal EMC pads are present in the receptacle, then they shall comply with the requirements defined in Figure 3-1. The shielding pads shall be connected to the receptacle shell. If no receptacle shell is present, then the receptacle shall provide a means to connect the shielding pad to ground. See Section 3.2.2.3 for a reference design of the shielding pad and ground connection.

7. This specification defines the USB Type-C receptacle shell length. To be certified at the connector level, a USB Type-C receptacle connector shall have features that comply with the defined shell dimensions. The shell length is not applicable when

- the USB Type-C receptacle certification is done at the system level instead of the component level. If a USB Type-C receptacle connector is certified at the system level, then the connector mounted in the associated system hardware shall pass all applicable electrical and mechanical compliance tests.
8. The USB Type-C connector mating interface is defined so that the electrical connection may be established without the receptacle shell. To prevent excessive misalignment of the plug when it enters or exits the receptacle, the enclosure should have features to guide the plug for insertion and withdrawal when a modified receptacle shell is present. If the USB Type-C receptacle shell is modified from the specified dimension, then the recommended lead in from the receptacle tongue to the plug point of entry is 1.5 mm minimum when mounted in the system.
 9. A paddle card (e.g., PCB) may be used in the USB Type-C plug to manage wire termination and electrical performance. Section 3.2.2.5 includes the guidelines and a design example for a paddle card.
 10. This specification does not define standard footprints. Figure 3-4 shows an example SMT (surface mount) footprint for the vertical receptacle shown in Figure 3-1. Additional reference footprints and mounting configurations are shown in Figure 3-5, Figure 3-6, Figure 3-7, and Figure 3-8.
 11. The receptacle shell shall be connected to the PCB ground plane.
 12. All VBUS pins shall be connected together in the USB Type-C plug.
 13. All Ground return pins shall be connected together in the USB Type-C plug.
 14. All VBUS pins shall be connected together at the USB Type-C receptacle when it is in its mounted condition (e.g., all VBUS pins bussed together in the PCB).
 15. All Ground return pins shall be connected together at the USB Type-C receptacle when it is in its mounted condition (e.g., all Ground return pins bussed together in the PCB).

Figure 3-1 USB Type-C Receptacle Interface Dimensions

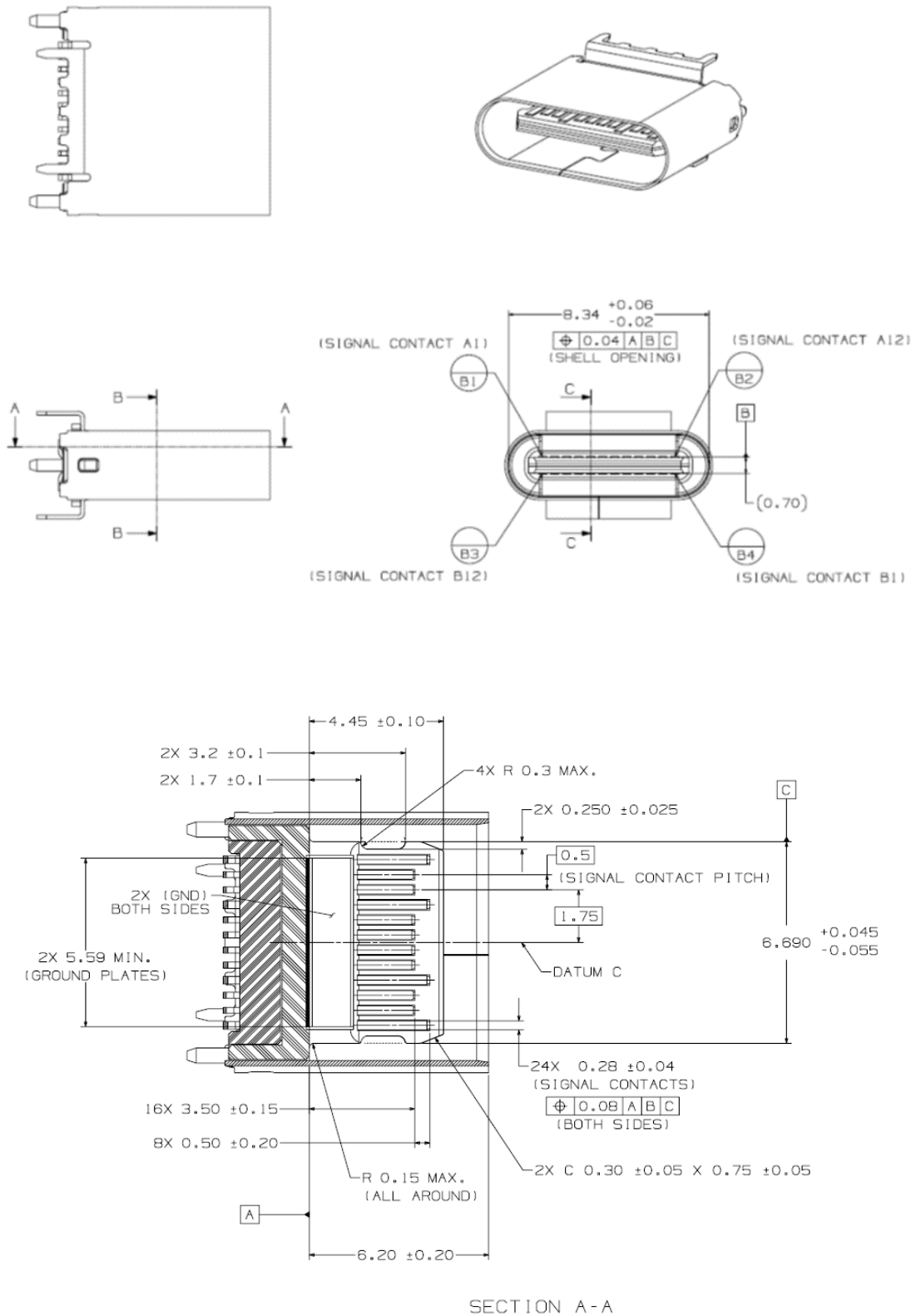

Figure 3-1 USB Type-C Receptacle Interface Dimensions, cont.

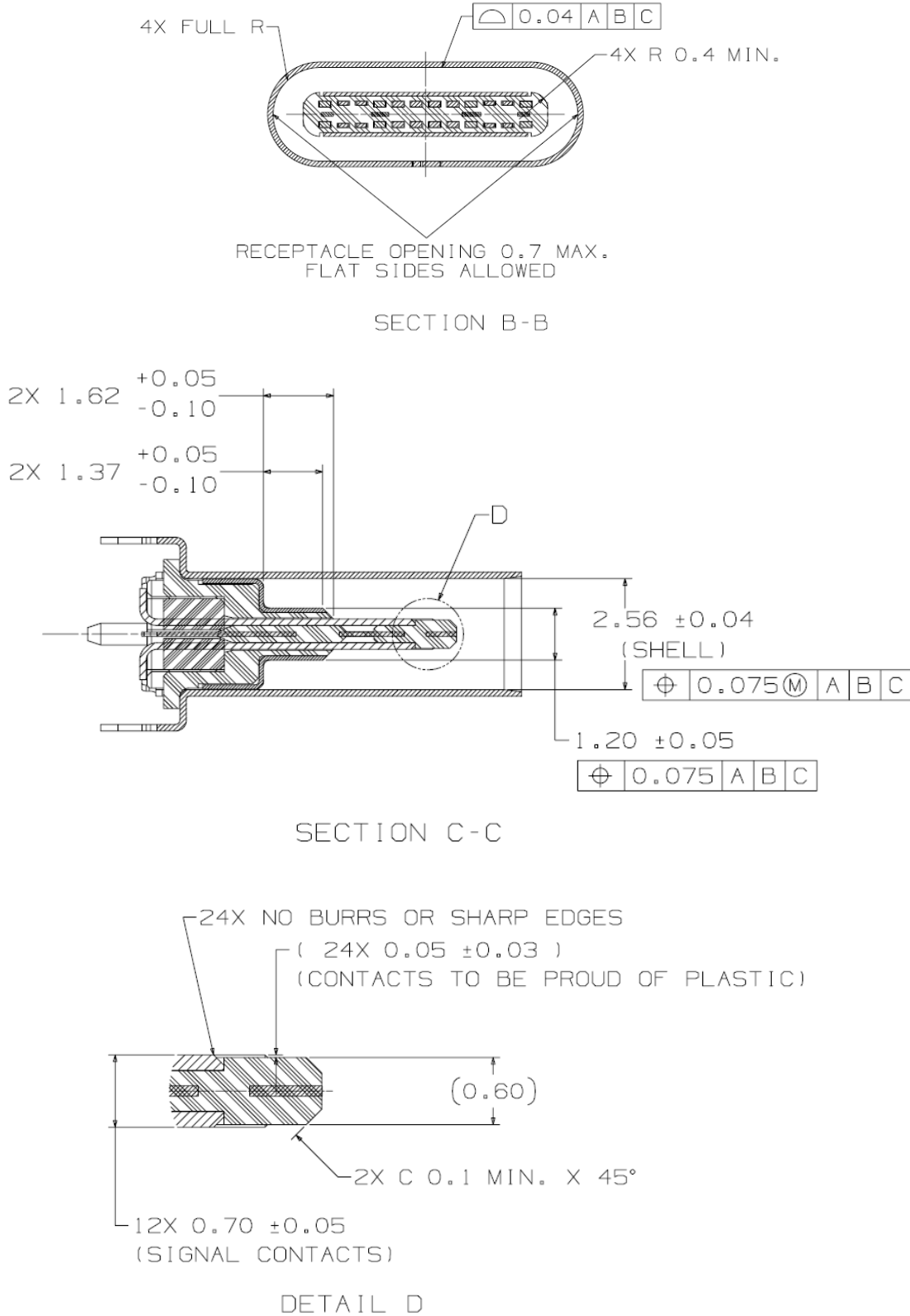

Figure 3-2 Reference Design USB Type-C Plug External EMC Spring Contact Zones

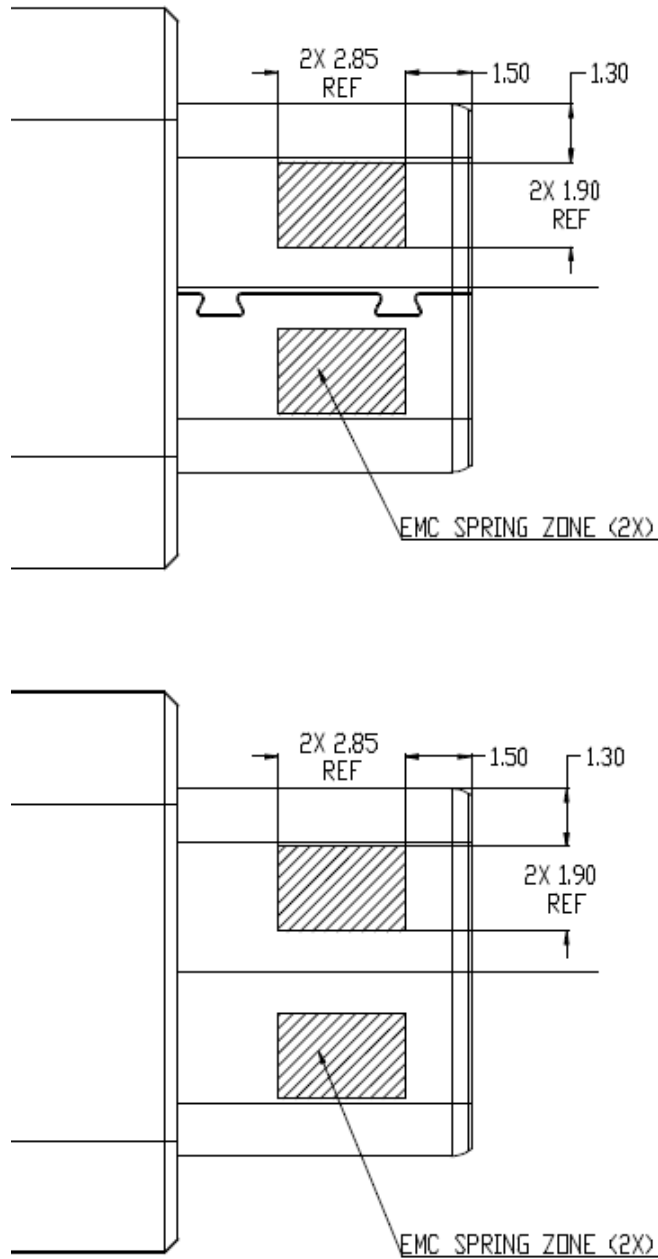

Figure 3-3 USB Full-Featured Type-C Plug Interface Dimensions

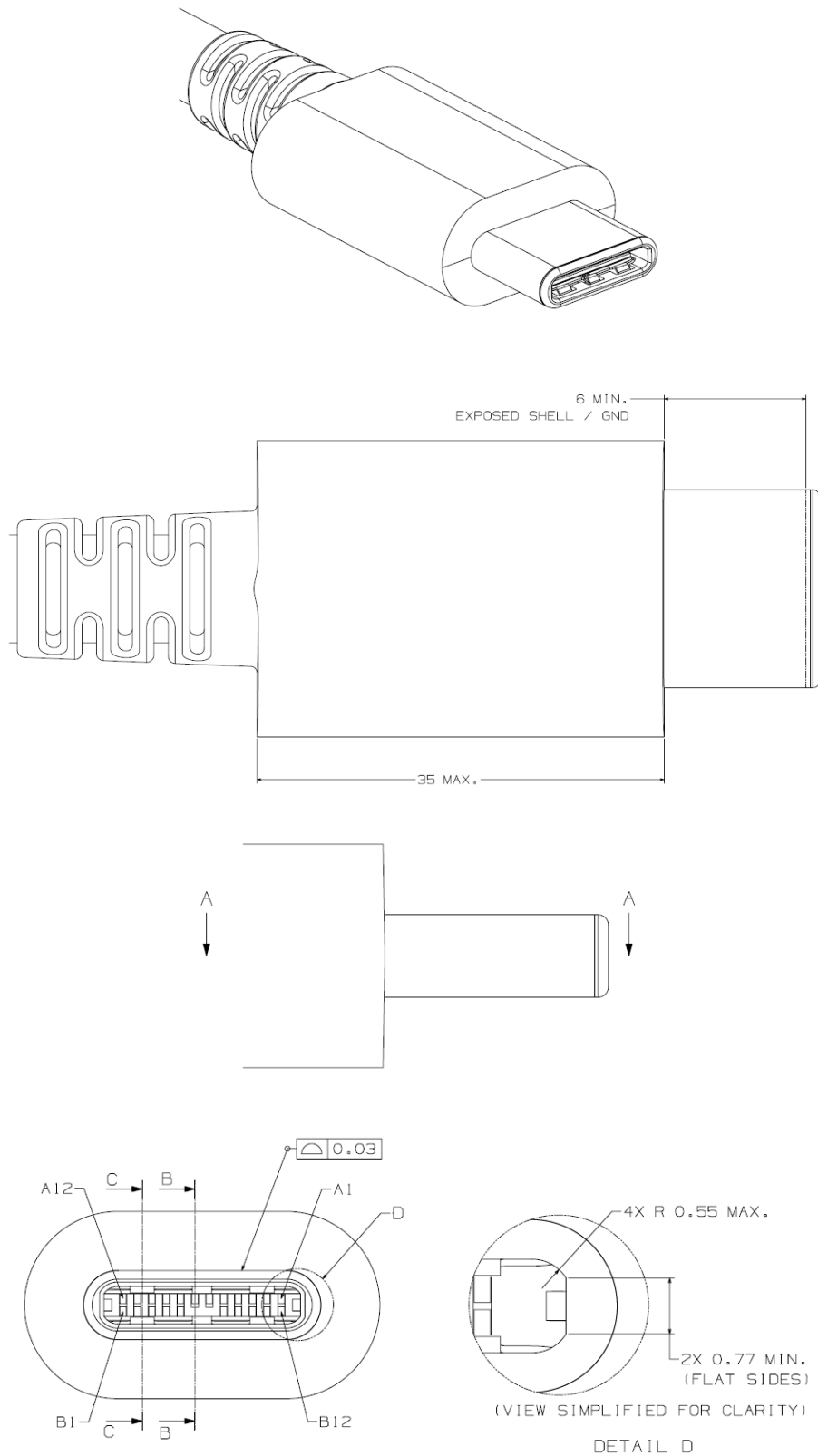

Figure 3-3 USB Full-Featured Type-C Plug Interface Dimensions, cont.

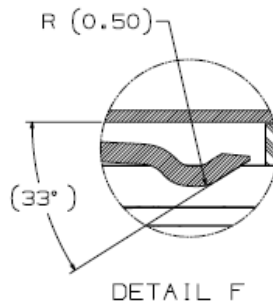
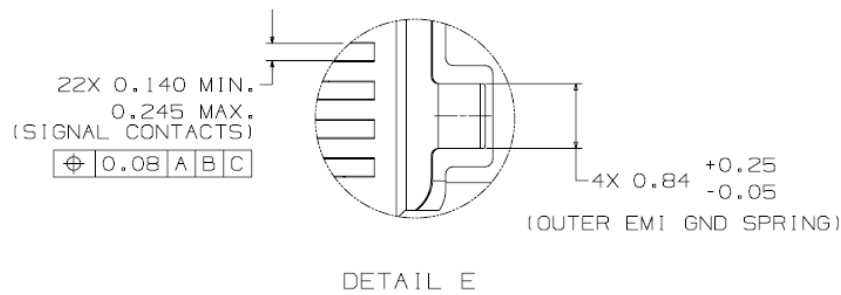
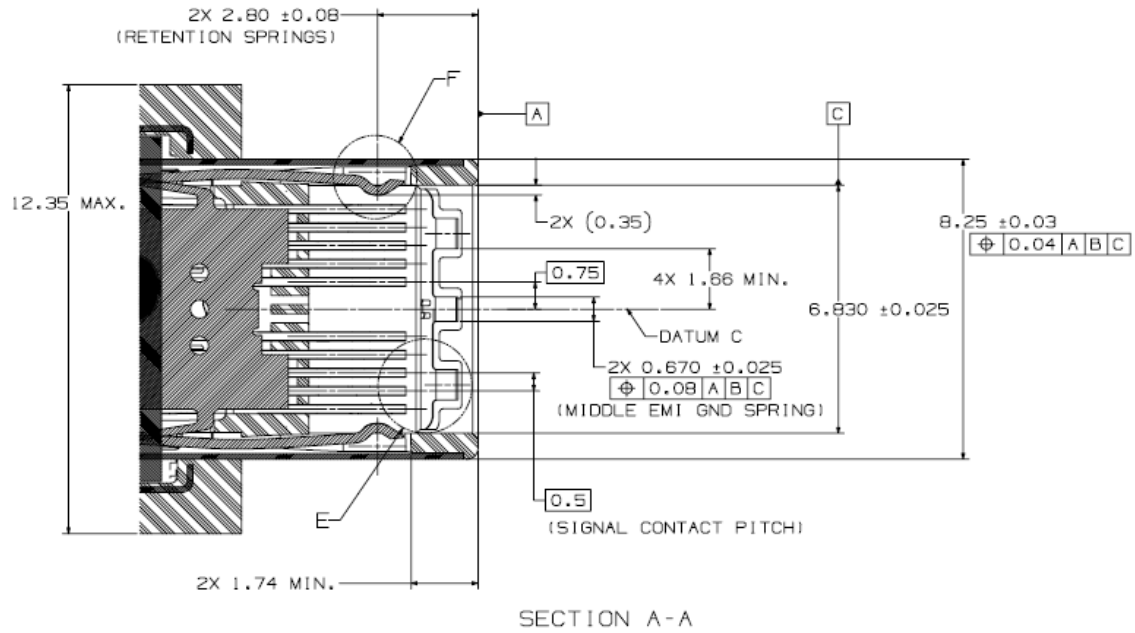
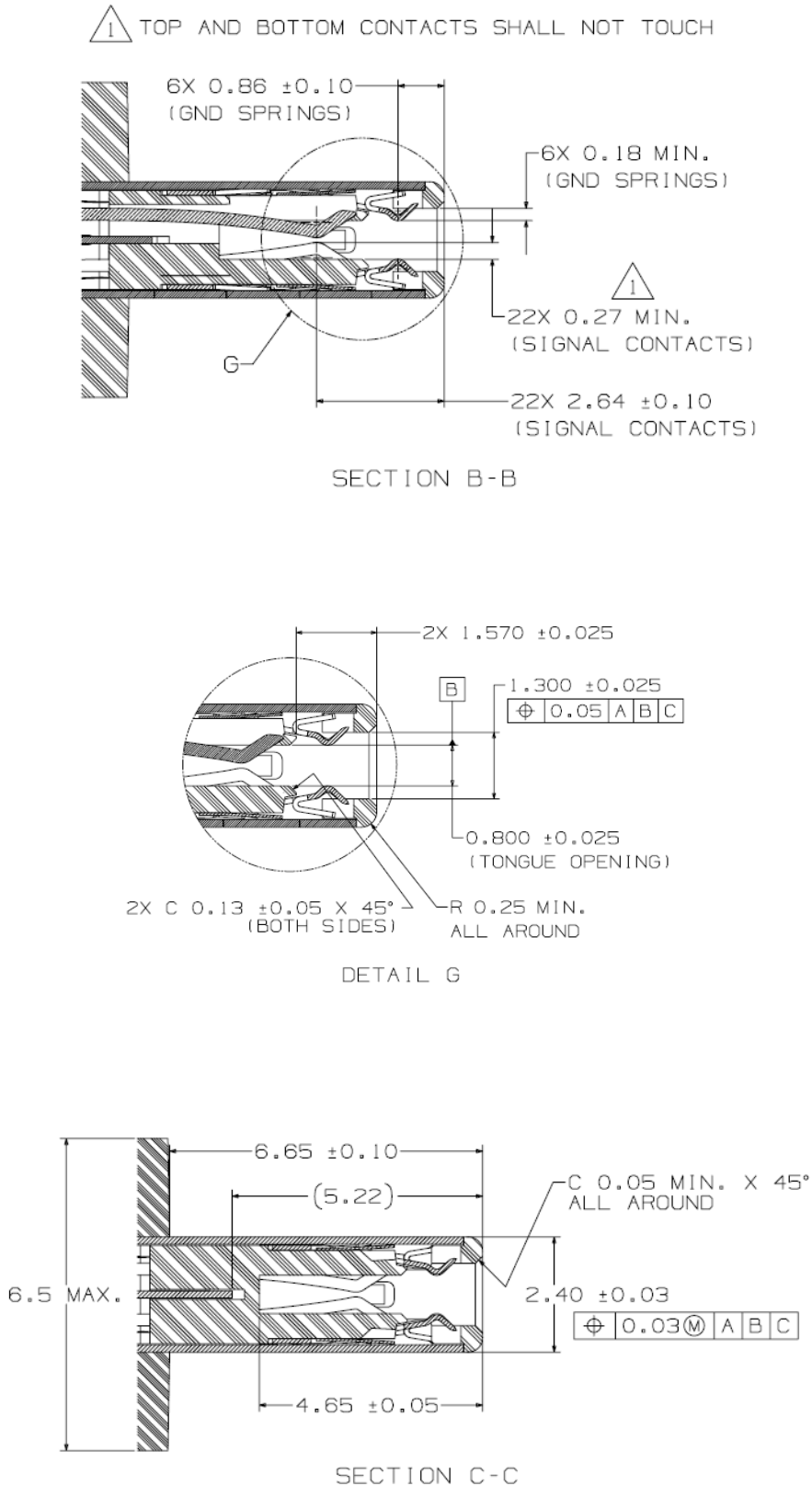

Figure 3-3 USB Full-Featured Type-C Plug Interface Dimensions, cont.



**Figure 3-4 Reference Footprint for a USB Type-C Vertical Mount Receptacle
(Informative)**

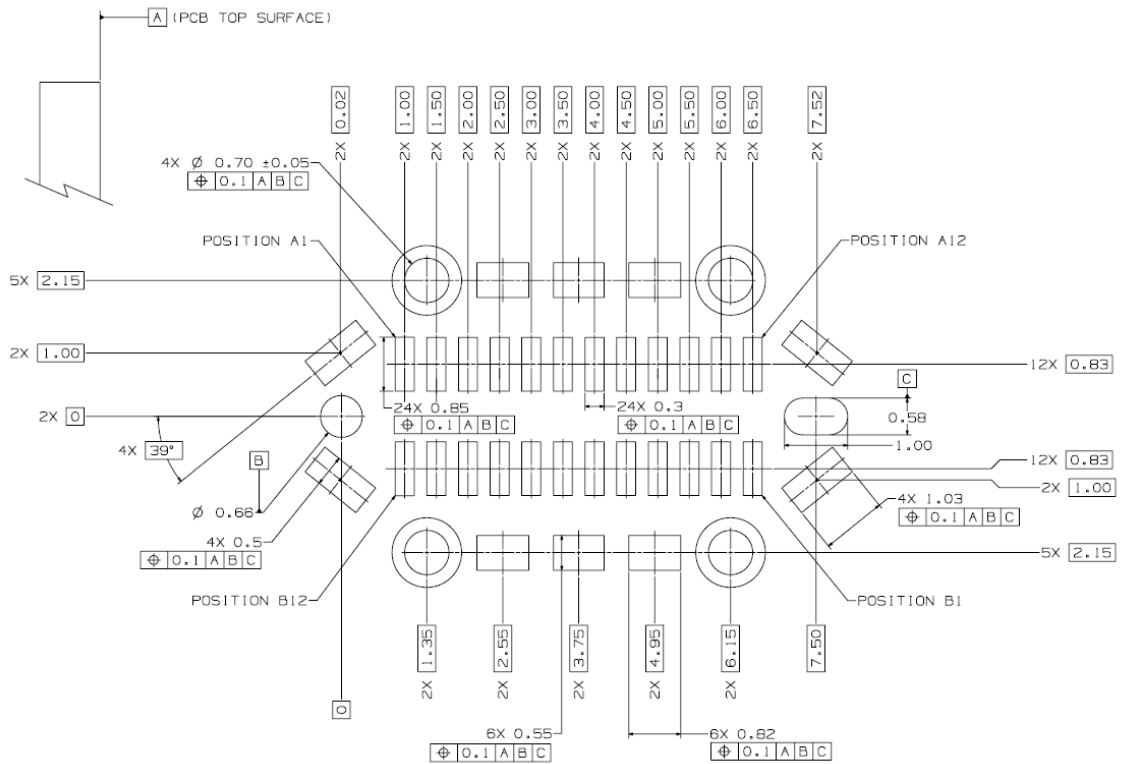
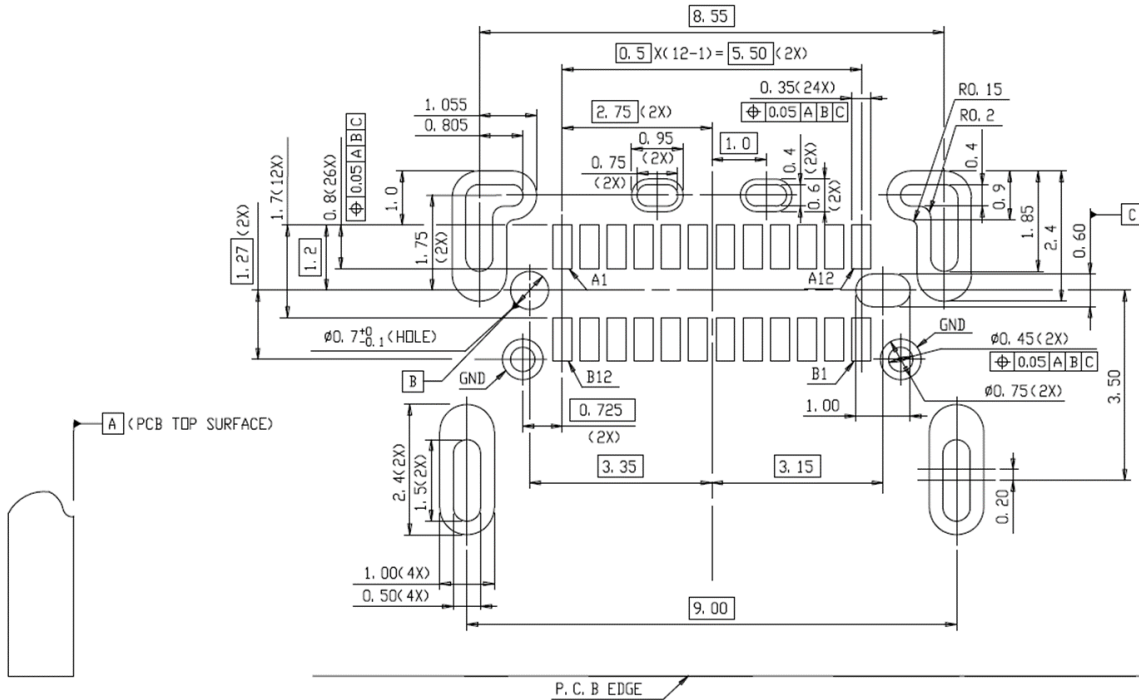
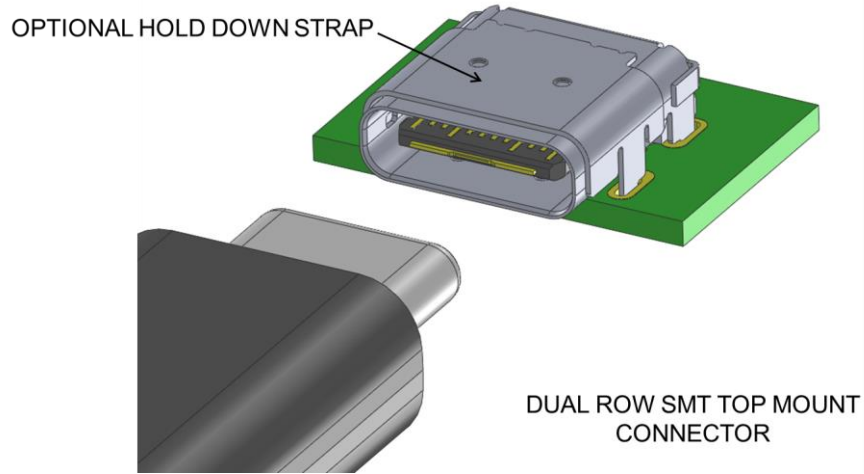

Figure 3-5 Reference Footprint for a USB Type-C Dual-Row SMT Right Angle Receptacle (Informative)



**Figure 3-6 Reference Footprint for a USB Type-C Hybrid Right-Angle Receptacle
(Informative)**

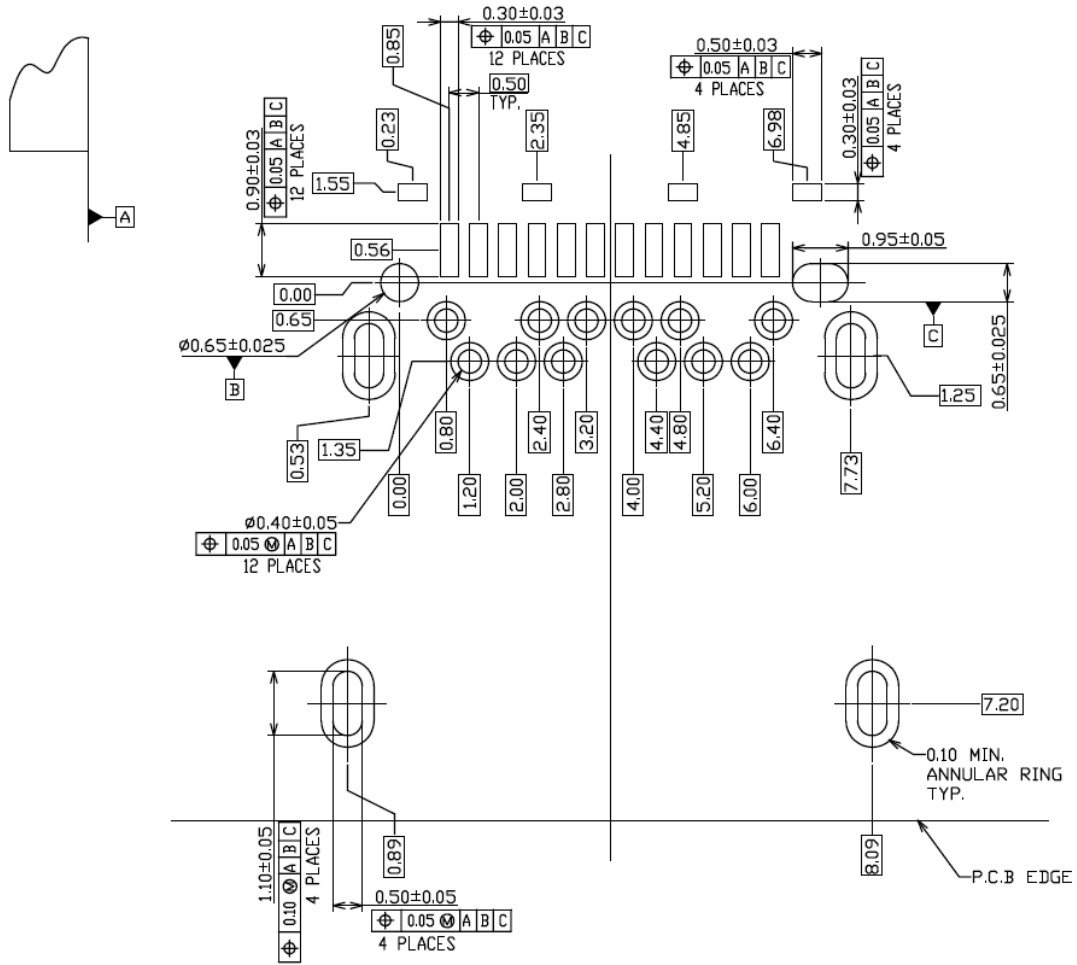
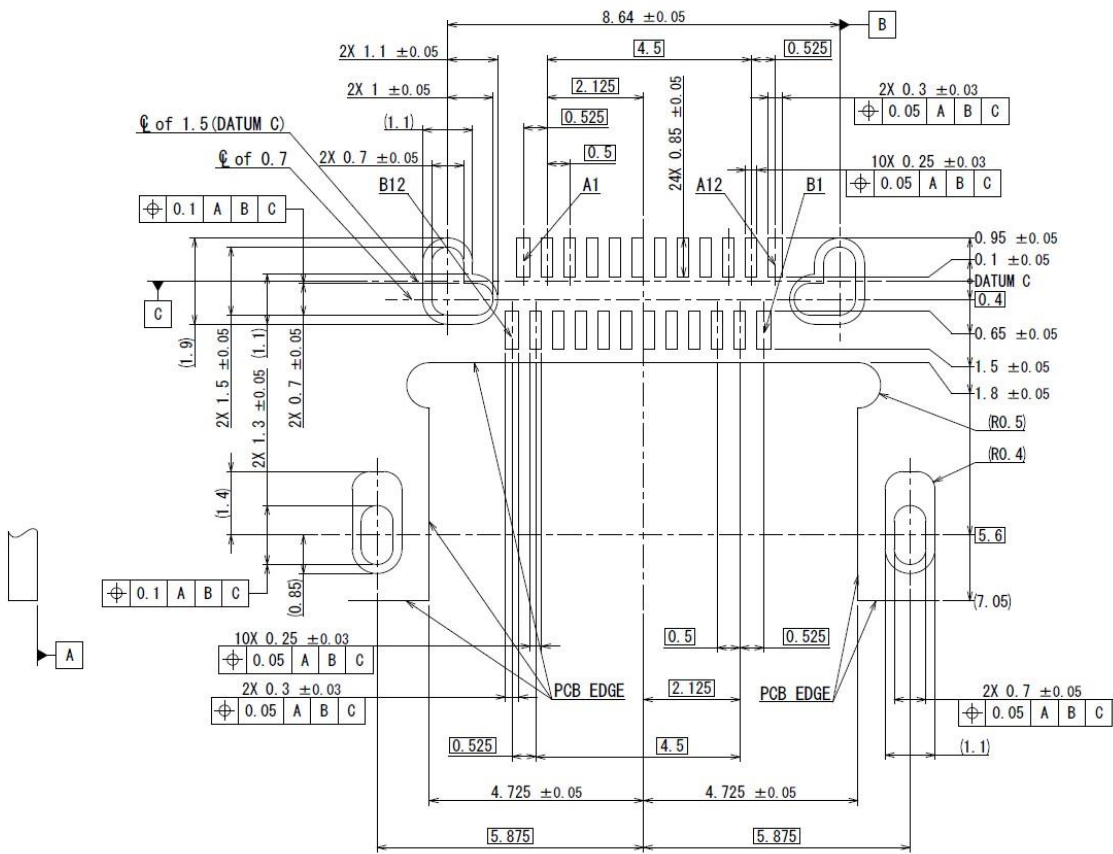
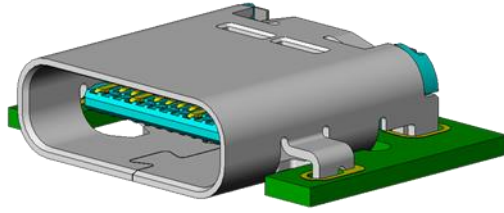
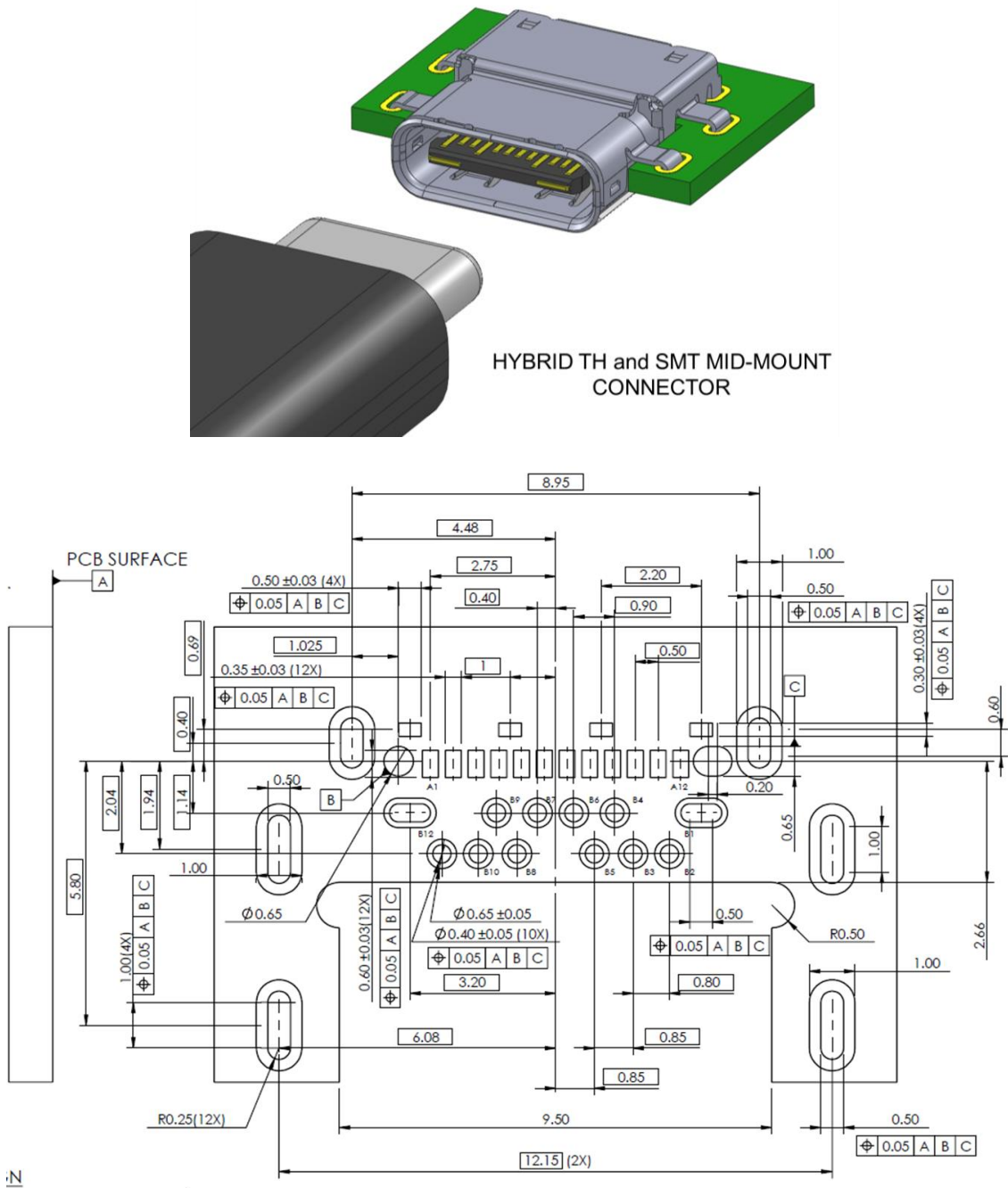

Figure 3-7 Reference Footprint for a USB Type-C Mid-Mount Dual-Row SMT Receptacle (Informative)



**Figure 3-8 Reference Footprint for a USB Type-C Mid-Mount Hybrid Receptacle
(Informative)**



This specification requires that all contacts be present in the mating interface of the USB Type-C receptacle connector, but allows the plug to include only the contacts required for [USB PD](#) and [USB 2.0](#) functionality for applications that only support [USB 2.0](#). The [USB 2.0](#) Type-C plug is shown in Figure 3-9. The following design simplifications may be made when only [USB 2.0](#) is supported:

- Only the contacts necessary to support [USB PD](#) and [USB 2.0](#) are required in the plug. All other pin locations may be unpopulated. See Table 3-5. All contacts are required to be present in the mating interface of the USB Type-C receptacle connector.
- Unlike the USB Full-Featured Type-C plug, the internal EMC springs may be formed from the same strip as the signal, power, and ground contacts. The internal EMC springs contact the inner surface of the plug shell and mate with the receptacle EMC pads when the plug is seated in the receptacle.
- A paddle card inside the plug may not be necessary if wires are directly attached to the contact pins.

Figure 3-9 [USB 2.0](#) Type-C Plug Interface Dimensions

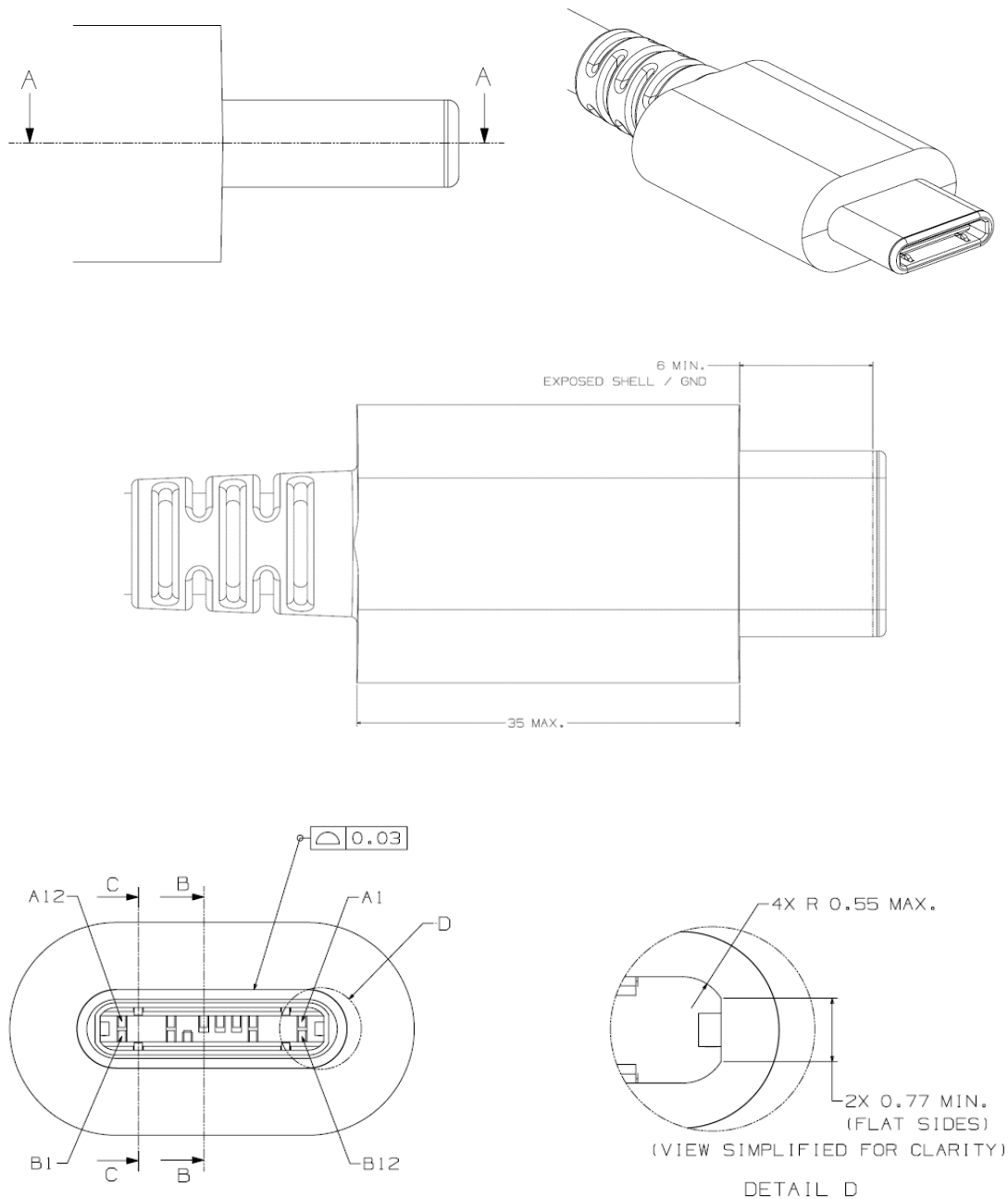

Figure 3-9 **USB 2.0** Type-C Plug Interface Dimensions, cont.

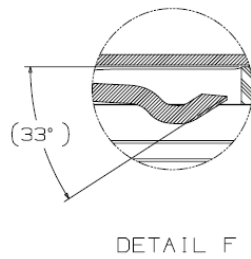
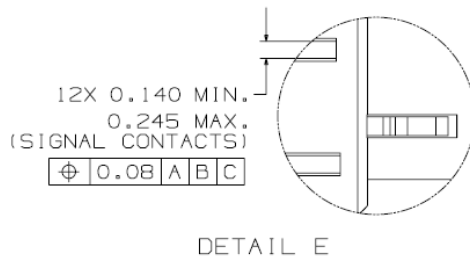
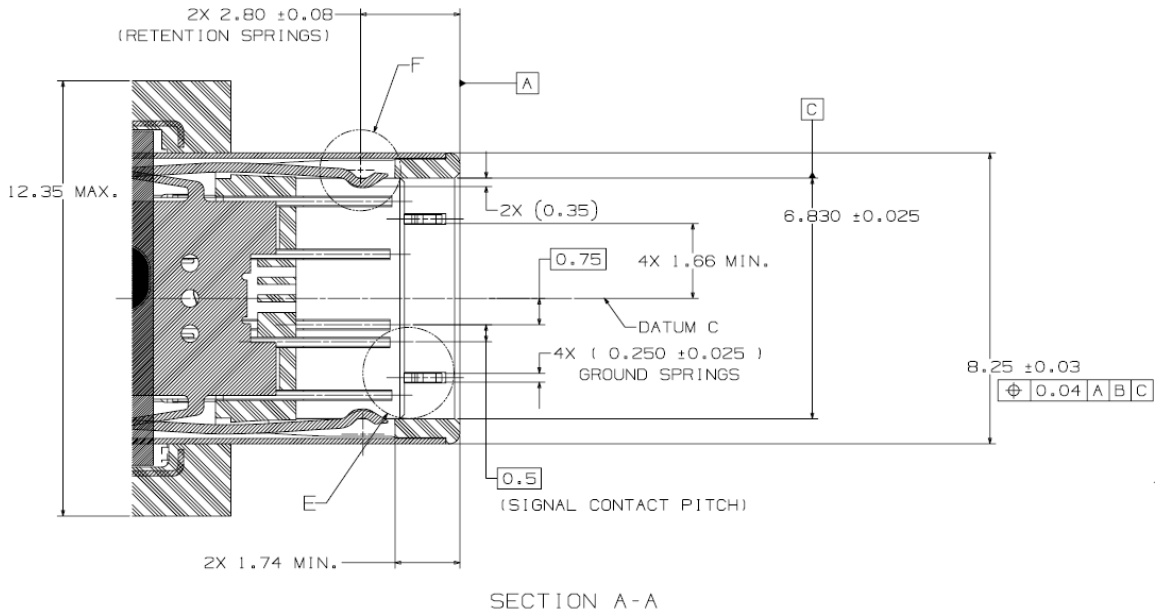
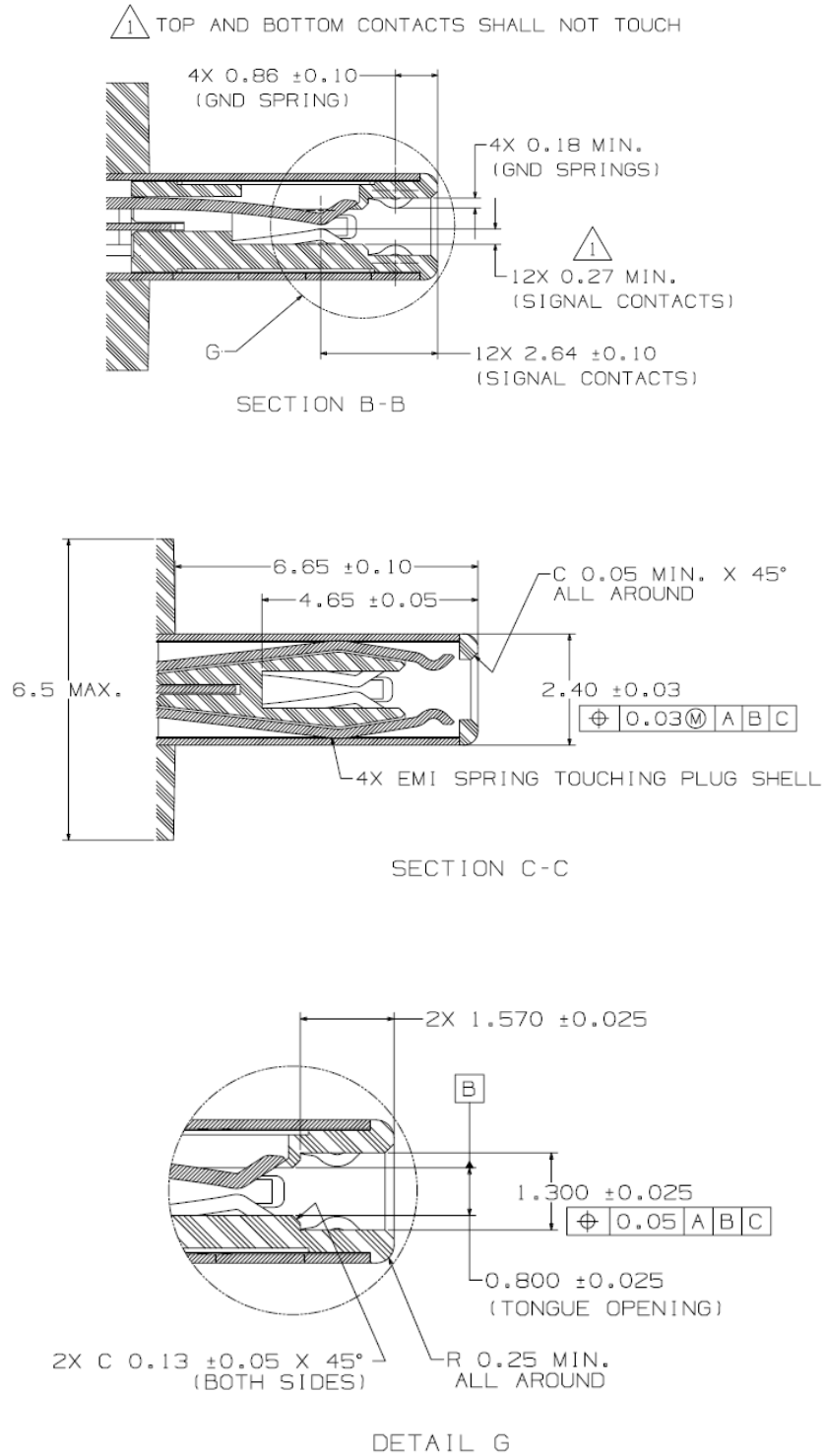

Figure 3-9 **USB 2.0** Type-C Plug Interface Dimensions, cont.



3.2.2 Reference Designs

This section provides reference designs for a few key features of the USB Type-C connector. The reference designs are provided as acceptable design examples. They are not normative.

3.2.2.1 Receptacle Mid-Plate (Informative)

The signals between the top and bottom of the receptacle tongue are isolated by a mid-plate inside the tongue. Figure 3-10 shows a reference design of the mid-plate. It is important to pay attention to the following features of the middle plate:

- The distance between the signal contacts and the mid-plate should be accurately controlled since the variation of this distance may significantly impact impedance of the connector.
- The mid-plate in this particular design protrudes slightly beyond the front surface of the tongue. This is to protect the tongue front surface from damage caused by mis-insertion of small objects into the receptacle.
- The mid-plate is required to be directly connected to the PCB ground with at least two grounding points.
- The sides of the mid-plate mate with the plug side latches, making ground connections to reduce EMC. Proper surface finishes are necessary in the areas where the side latches and mid-plate connections occur.

Figure 3-10 Reference Design of Receptacle Mid-Plate

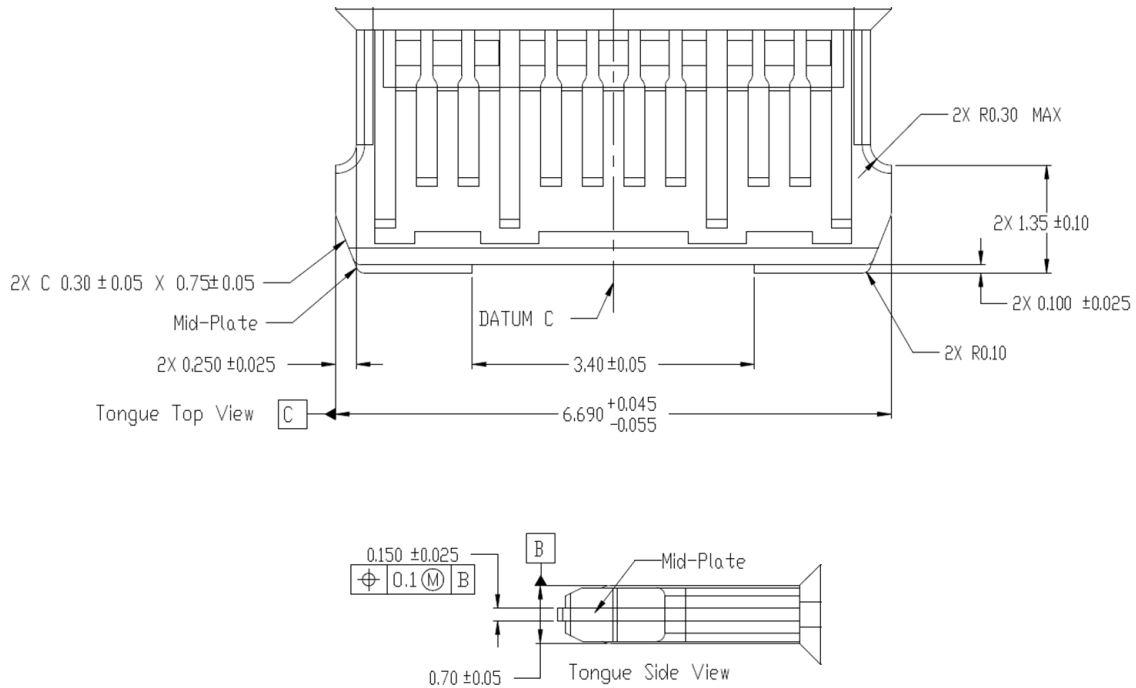

3.2.2.2 Side Latch (informative)

The side latches (retention latches) are located in the plug. Figure 3-11 shows a reference design of a blanked side latch. The plug side latches should contact the receptacle mid-plate to provide an additional ground return path.

Figure 3-11 Reference Design of the Retention Latch

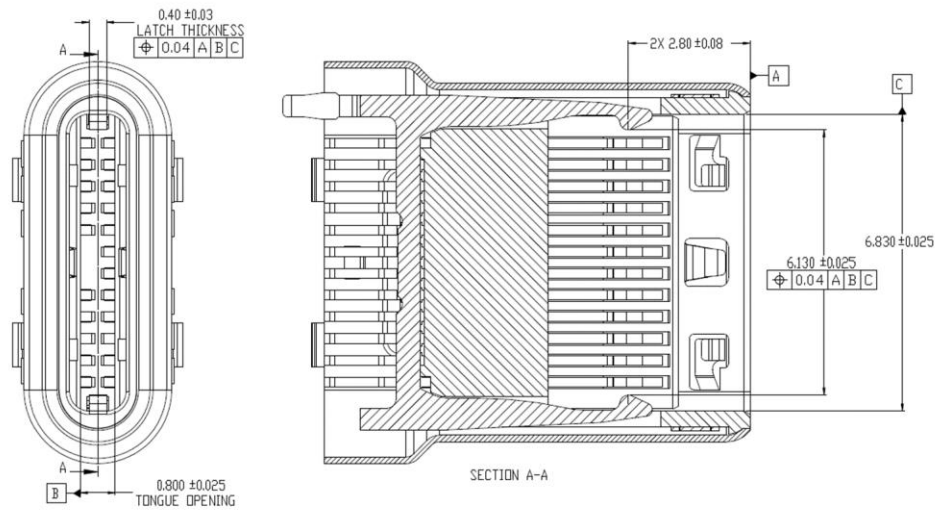
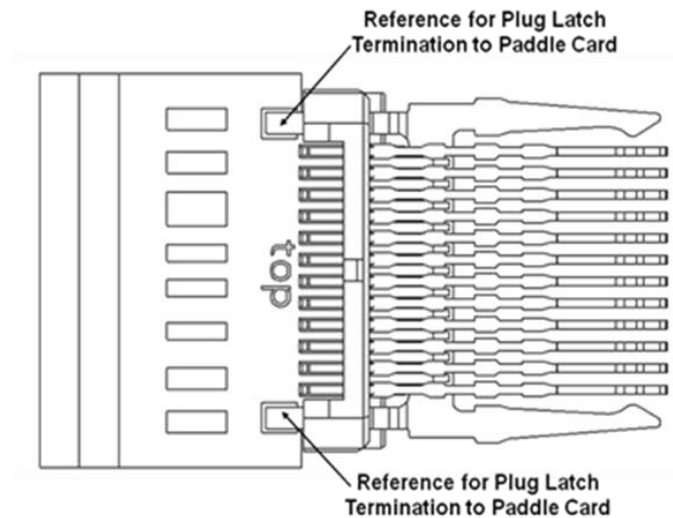

Figure 3-12 Illustration of the Latch Soldered to the Paddle Card Ground



3.2.2.3 Internal EMI Springs and Pads (Informative)

Figure 3-13 is a reference design of the internal EMC spring located inside the USB Full-Featured Type-C plug. Figure 3-14 is a reference design of the internal EMC spring located inside the [USB 2.0](#) Type-C plug.

Figure 3-13 Reference Design of the USB Full-Featured Type-C Plug Internal EMC Spring

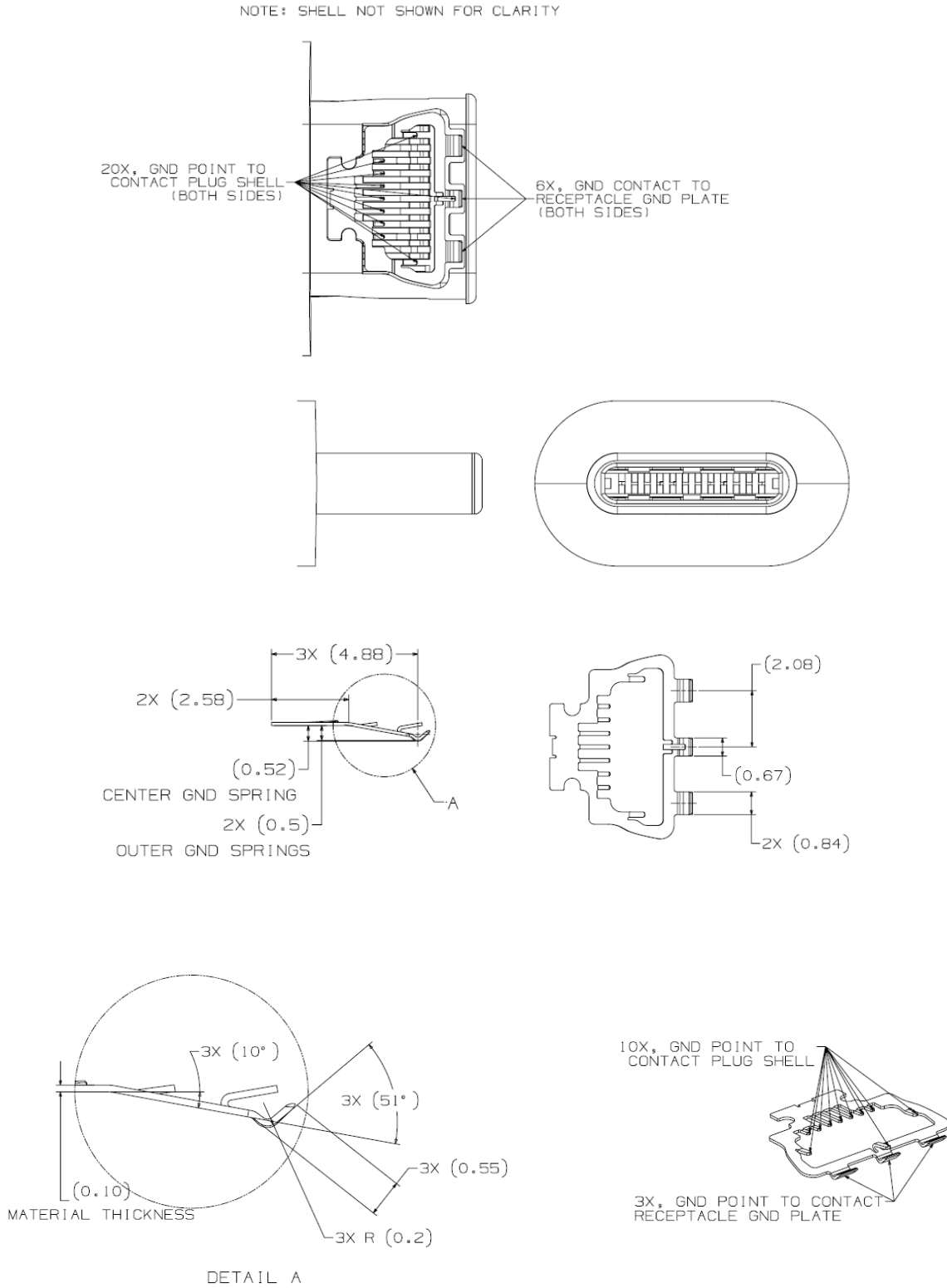
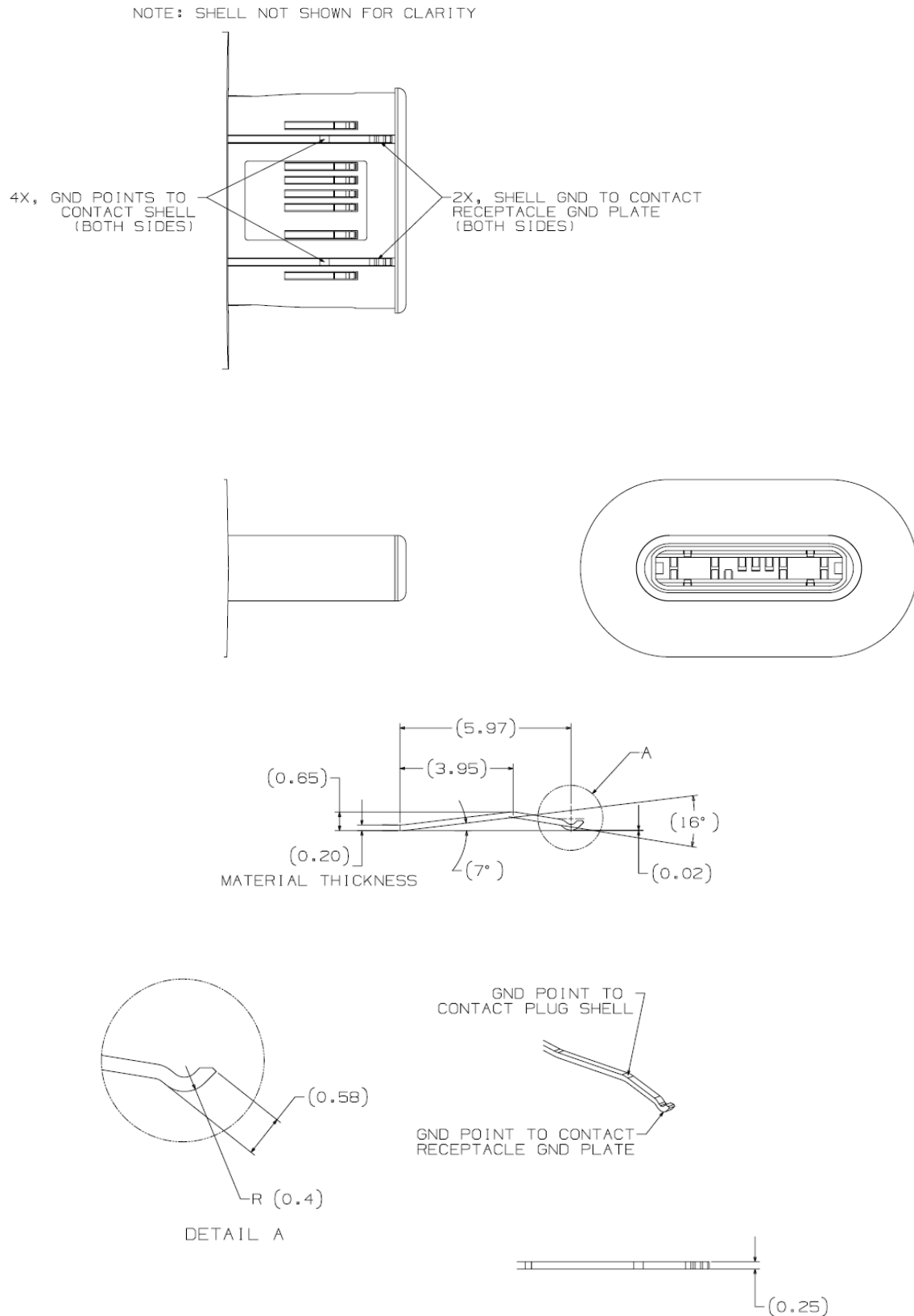

Figure 3-14 Reference Design of the USB 2.0 Type-C Plug Internal EMC Spring



It is critical that the internal EMC spring contacts the plug shell as close to the EMC spring mating interface as possible to minimize the length of the return path.

The internal EMC pad (i.e., ground plate) shown in Figure 3-15 is inside the receptacle. It mates with the EMC spring in the plug. To provide an effective ground return, the EMC pads should have multiple connections with the receptacle shell.

Figure 3-15 Reference Design of Internal EMC Pad

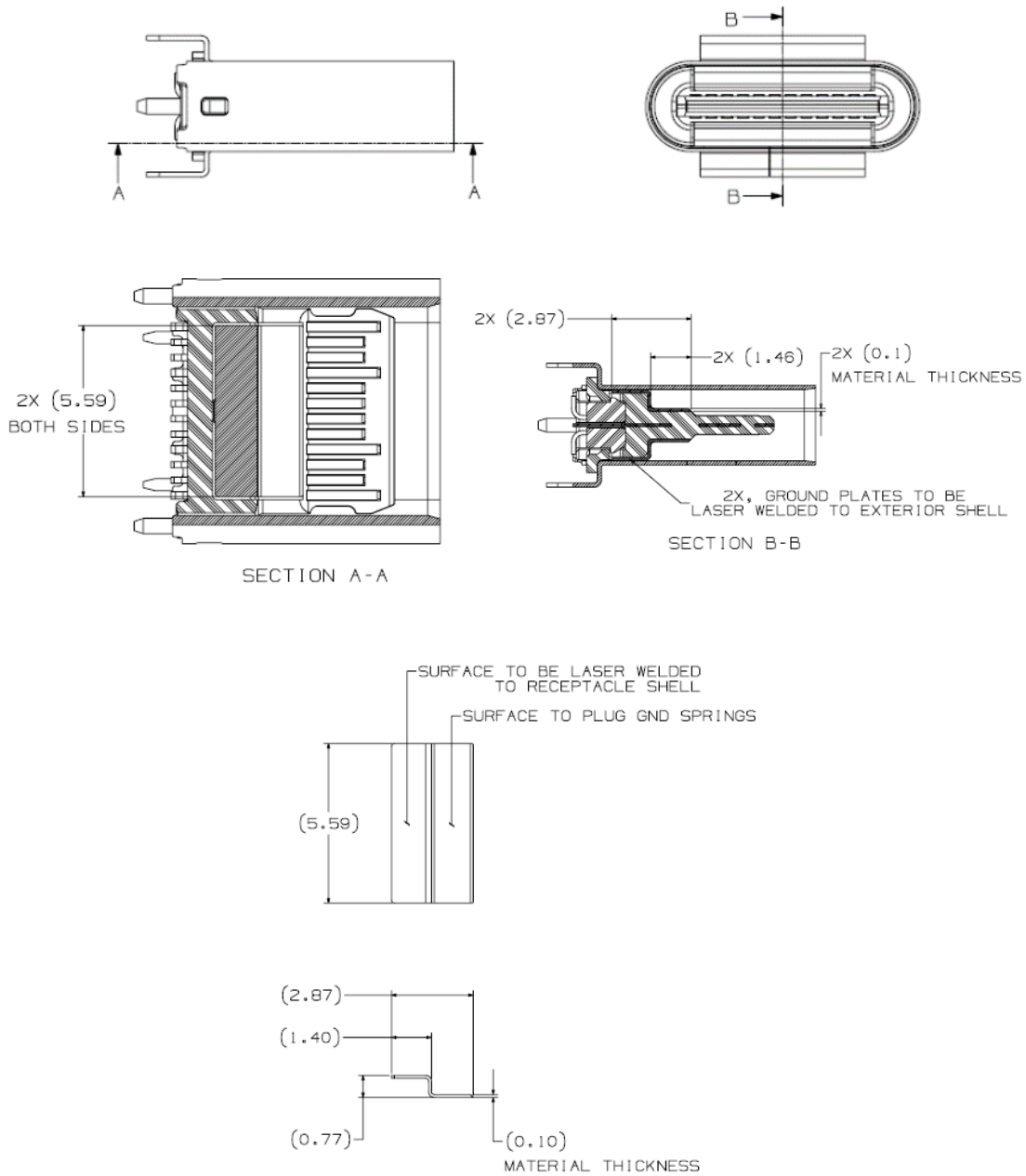

3.2.2.4 Optional External Receptacle EMC Springs (Informative)

Some applications may use receptacles with EMC springs that contact the outside of the plug shell. Figure 3-16 shows a reference receptacle design with external EMC springs. The EMC spring contact landing zones for the fully mated condition are normative and defined in Section 3.2.1.

Figure 3-16 Reference Design of a USB Type-C Receptacle with External EMC Springs

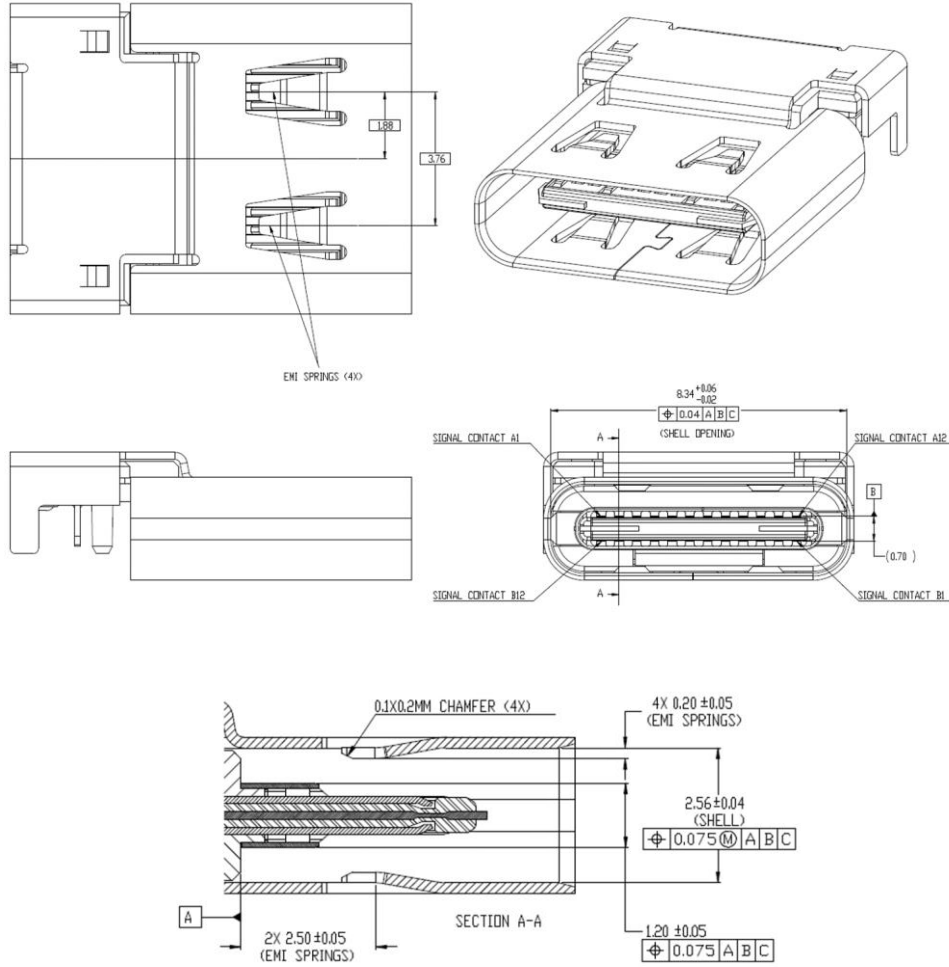

3.2.2.5 USB Full-Featured Type-C Plug Paddle Card (Informative)

The use of a paddle card is expected in the USB Full-Featured Type-C Plug. Figure 3-17 illustrates the paddle card pin assignment and contact spring connection location for a USB Full-Featured Type-C plug. The following guidelines are provided for the paddle card design:

- The paddle card should use high performance substrate material. The recommended paddle card thickness should have a tolerance less than or equal to $\pm 10\%$.
- The USB SuperSpeed traces should be as short as possible and have a nominal differential characteristic impedance of 85Ω .
- The differential pairs should have a minimum pair-to pair separation of 0.5 mm.
- It is recommended that a grounded coplanar waveguide (CPWG) system be selected as a transmission line method.
- Use of vias should be minimized.
- VBUS pins should be bussed together on the paddle card.
- GND pins should be bussed together on the paddle card.

Figure 3-17 Reference Design for a USB Full-Featured Type-C Plug Paddle Card

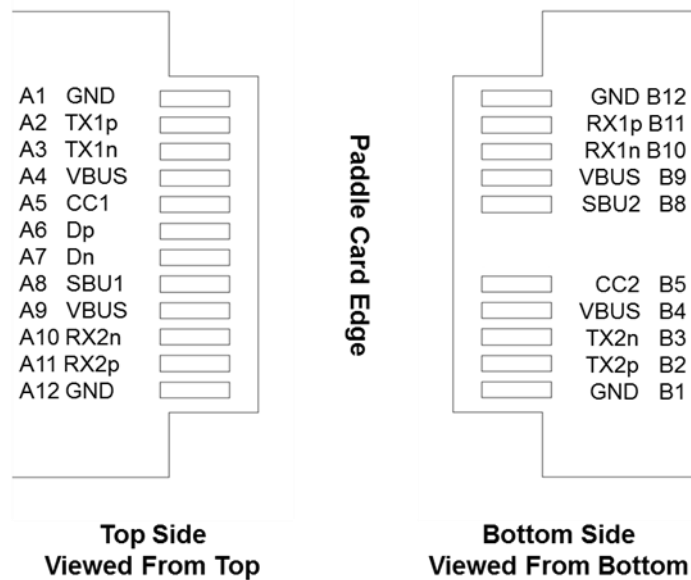

3.2.3 Pin Assignments and Descriptions

The usage and assignments of the 24 pins for the USB Type-C receptacle interface are defined in Table 3-4.

Table 3-4 USB Type-C Receptacle Interface Pin Assignments

Pin	Signal Name	Description	Mating Sequence	Pin	Signal Name	Description	Mating Sequence
A1	GND	Ground return	First	B12	GND	Ground return	First
A2	SSTXp1	Positive half of first SuperSpeed TX differential pair	Second	B11	SSRXp1	Positive half of first SuperSpeed RX differential pair	Second
A3	SSTXn1	Negative half of first SuperSpeed TX differential pair	Second	B10	SSRXn1	Negative half of first SuperSpeed RX differential pair	Second
A4	VBUS	Bus Power	First	B9	VBUS	Bus Power	First
A5	CC1	Configuration Channel	Second	B8	SBU2	Sideband Use (SBU)	Second
A6	Dp1	Positive half of the USB 2.0 differential pair – Position 1	Second	B7	Dn2	Negative half of the USB 2.0 differential pair – Position 2	Second
A7	Dn1	Negative half of the USB 2.0 differential pair – Position 1	Second	B6	Dp2	Positive half of the USB 2.0 differential pair – Position 2	Second
A8	SBU1	Sideband Use (SBU)	Second	B5	CC2	Configuration Channel	Second
A9	VBUS	Bus Power	First	B4	VBUS	Bus Power	First
A10	SSRXn2	Negative half of second SuperSpeed RX differential pair	Second	B3	SSTXn2	Negative half of second SuperSpeed TX differential pair	Second
A11	SSRXp2	Positive half of second SuperSpeed RX differential pair	Second	B2	SSTXp2	Positive half of second SuperSpeed TX differential pair	Second
A12	GND	Ground return	First	B1	GND	Ground return	First

Notes:

1. Contacts B6 and B7 should not be present in the USB Type-C plug. The receptacle side shall support the [USB 2.0](#) differential pair present on Dp1/Dn1 or Dp2/Dn2. The plug orientation determines which pair is active. In one implementation, Dp1 and Dp2 may be shorted on the host/device as close to the receptacle as possible to minimize stub length; Dn1 and Dn2 may also be shorted. The maximum shorting trace length should not exceed 3.5 mm.
2. All VBUS pins shall be connected together within the USB Type-C plug and shall be connected together at the USB Type-C receptacle connector when the receptacle is in its mounted condition (e.g., all VBUS pins bussed together on the PCB).
3. All Ground return pins shall be connected together within the USB Type-C plug and shall be connected together at the USB Type-C receptacle connector when the receptacle is in its mounted condition (e.g., all ground return pins bussed together on the PCB).

The usage and assignments of the signals necessary for the support of only [USB 2.0](#) with the USB Type-C mating interface are defined in Table 3-5.

Table 3-5 USB Type-C Receptacle Interface Pin Assignments for USB 2.0-only Support

Pin	Signal Name	Description	Mating Sequence	Pin	Signal Name	Description	Mating Sequence
A1	GND	Ground return	First	B12	GND	Ground return	First
A2				B11			
A3				B10			
A4	VBUS	Bus Power	First	B9	VBUS	Bus Power	First
A5	CC1	Configuration Channel	Second	B8	SBU2	Sideband Use (SBU)	Second
A6	Dp1	Positive half of the USB 2.0 differential pair – Position 1	Second	B7	Dn2	Negative half of the USB 2.0 differential pair – Position 2	Second
A7	Dn1	Negative half of the USB 2.0 differential pair – Position 1	Second	B6	Dp2	Positive half of the USB 2.0 differential pair – Position 2	Second
A8	SBU1	Sideband Use (SBU)	Second	B5	CC2	Configuration Channel	Second
A9	VBUS	Bus Power	First	B4	VBUS	Bus Power	First
A10				B3			
A11				B2			
A12	GND	Ground return	First	B1	GND	Ground return	First

Notes:

1. The unused contacts shall not be physically depopulated in the USB Type-C receptacle. Unused contact locations shall be electrically isolated from power, ground or signaling (i.e., not connected).
2. Contacts B6 and B7 should not be present in the USB Type-C plug. The receptacle side shall support the [USB 2.0](#) differential pair present on Dp1/Dn1 or Dp2/Dn2. The plug orientation determines which pair is active. In one implementation, Dp1 and Dp2 may be shorted on the host/device as close to the receptacle as possible to minimize stub length; Dn1 and Dn2 may also be shorted. The maximum shorting trace length should not exceed 3.5 mm.
3. Contacts A8 and B8 (SBU1 and SBU2) shall be not connected unless required for a specified purpose (e.g., [Audio Adapter Accessory Mode](#)).
4. All VBUS pins shall be connected together within the USB Type-C plug and shall be connected together at the USB Type-C receptacle connector when the receptacle is in its mounted condition (e.g., all VBUS pins bussed together on the PCB).
5. All Ground return pins shall be connected together within the USB Type-C plug and shall be connected together at the USB Type-C receptacle connector when the receptacle is in its mounted condition (e.g., all ground return pins bussed together on the PCB).

3.3 Cable Construction and Wire Assignments

This section discusses the USB Type-C cables, including cable construction, wire assignments, and wire gauges.

3.3.1 Cable Construction (Informative)

Figure 3-18 illustrates an example of USB Full-Featured Type-C cable cross-section, using micro-coaxial wires for USB SuperSpeed. There are four groups of wires: USB D+/D– (typically unshielded twisted pairs (UTP)), USB SuperSpeed signal pairs (coaxial wires, twin-axial or shielded twisted pairs), sideband signal wires, and power and ground wires. In this example, the optional VCONN wire is shown whereas in Figure 3-19 the example is shown with the VCONN wire removed – the inclusion of VCONN or not relates to the implementation approach chosen for electronically marked cables (See Section 4.9).

Figure 3-18 Illustration of a USB Full-Featured Type-C Cable Cross Section, a Coaxial Wire Example with VCONN

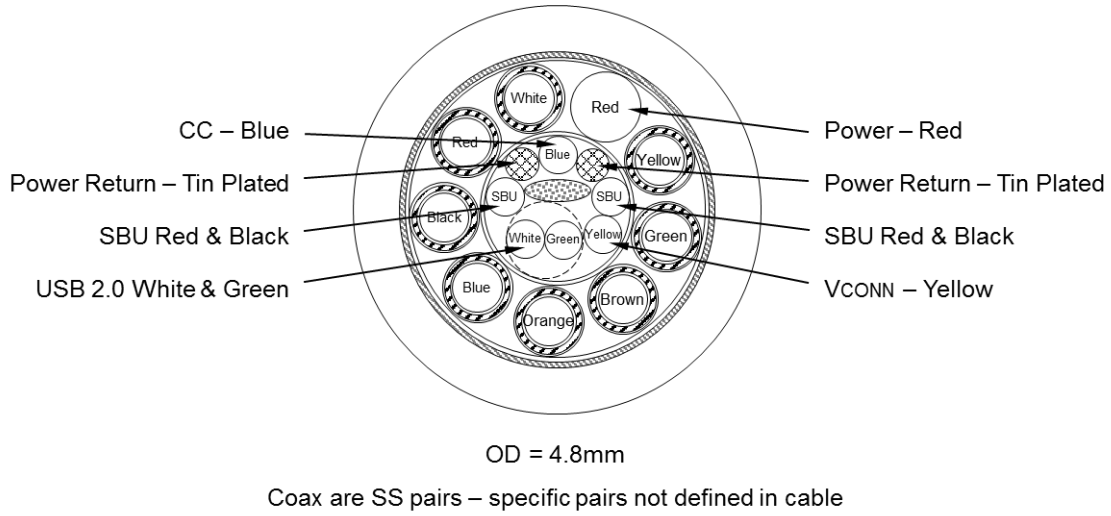
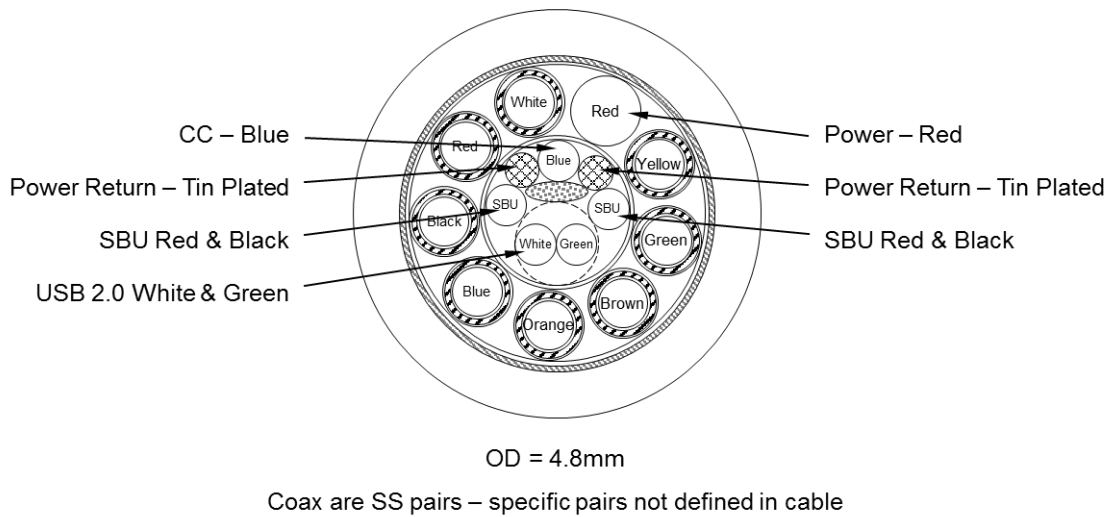

Figure 3-19 Illustration of a USB Full-Featured Type-C Cable Cross Section, a Coaxial Wire Example without VCONN



The USB D+/D- signal pair is intended to transmit the [USB 2.0](#) Low-Speed, Full-Speed and High-Speed signaling while the SuperSpeed signal pairs are used for [USB 3.1](#) SuperSpeed signaling. Shielding is needed for the SuperSpeed differential pairs for signal integrity and EMC performance.

3.3.2 Wire Assignments

Table 3-6 defines the full set of possible wires needed to produce all standard USB Type-C cables assemblies. For some cable assemblies, not all of these wires are used. For example, a USB Type-C cable that only provides [USB 2.0](#) functionality will not include wires 6–15.

Table 3-6 USB Type-C Standard Cable Wire Assignments

Wire Number	Signal Name	Description
1	GND_PWRrt1	Ground for power return
2	PWR_VBUS1	VBUS power
3	CC	Configuration Channel
4	UTP_Dp	Unshielded twist pair, positive
5	UTP_Dn	Unshielded twist pair, negative
6	SDPp1	Shielded differential pair #1, positive
7	SDPn1	Shielded differential pair #1, negative
8	SDPp2	Shielded differential pair #2, positive
9	SDPn2	Shielded differential pair #2, negative
10	SDPp3	Shielded differential pair #3, positive
11	SDPn3	Shielded differential pair #3, negative
12	SDPp4	Shielded differential pair #4, positive
13	SDPn4	Shielded differential pair #4, negative
14	SBU_A	Sideband Use
15	SBU_B	Sideband Use
16	GND_PWRrt2	Ground for power return (optional)
17	PWR_VBUS2	VBUS power (optional)
18	PWR_VCONN	VCONN power (optional, see Section 4.9)
Braid	Shield	Cable external braid

Note:

1. This table is based on the assumption that coaxial wire construction is used for all SDP's and there are no drain wires. The signal ground return is through the shields of the coaxial wires. If shielded twisted or twin-axial pairs are used, then drain wires are needed.

Table 3-7 defines the full set of possible wires needed to produce USB Type-C to legacy cable assemblies. For some cable assemblies, not all of these wires are needed. For example, a USB Type-C to [USB 2.0](#) Standard-B cable will not include wires 5-10.

Table 3-7 USB Type-C Cable Wire Assignments for Legacy Cables/Adapters

Wire Number	Signal Name	Description
1	GND_PWRrt1	Ground for power return
2	PWR_VBUS1	VBUS power
3	UTP_Dp	Unshielded twist pair, positive
4	UTP_Dn	Unshielded twist pair, negative
5	SDPp1	Shielded differential pair #1, positive
6	SDPn1	Shielded differential pair #1, negative
7	SDP1_Drain	Drain wire for SDPp1 and SDPn1
8	SDPp2	Shielded differential pair #2, positive
9	SDPn2	Shielded differential pair #2, negative
10	SDP2_Drain	Drain wire for SDPp2 and SDPn2
Braid	Shield	Cable external braid

Note:

1. This table is based on the assumption that shielded twisted pair is used for all SDP's and there are drain wires. If coaxial wire construction is used, then no drain wires are needed and the signal ground return is through the shields of the coaxial wires.

3.3.3 Wire Gauges and Cable Diameters (Informative)

This specification does not specify wire gauge. Table 3-8 and Table 3-9 list typical wire gauges for reference purposes only. A large gauge wire incurs less loss, but at the cost of cable diameter and flexibility. Multiple wires may be used for a single wire such as for VBUS or Ground. It is recommended to use the smallest possible wire gauges that meet the cable assembly electrical and mechanical requirements.

To maximize cable flexibility, all wires should be stranded and the cable outer diameter should be minimized as much as possible. A typical USB Full-Featured Type-C cable outer diameter may range from 4 mm to 6 mm while a typical [USB 2.0](#) Type-C cable outer diameter may range from 2 mm to 4 mm. A typical USB Type-C to [USB 3.1](#) legacy cable outer diameter may range from 3 mm to 5 mm.

Table 3-8 Reference Wire Gauges for standard USB Type-C Cable Assemblies

Wire Number	Signal Name	Wire Gauge (AWG)
1	GND_PWRrt1	20-28
2	PWR_VBUS1	20-28
3	CC	32-34
4	UTP_Dp	28-34
5	UTP_Dn	28-34
6	SDPp1	26-34
7	SDPn1	26-34
8	SDPp2	26-34
9	SDPn2	26-34
10	SDPp3	26-34
11	SDPn3	26-34
12	SDPp4	26-34
13	SDPn4	26-34
14	SBU_A	32-34
15	SBU_B	32-34
16	GND_PWRrt2	20-28
17	PWR_VBUS2	20-28
18	PWR_VCONN	32-34

Table 3-9 Reference Wire Gauges for USB Type-C to Legacy Cable Assemblies

Wire Number	Signal Name	Wire Gauge (AWG)
1	GND_PWRrt1	20-28
2	PWR_VBUS1	20-28
3	UTP_Dp	28-34
4	UTP_Dn	28-34
5	SDPp1	26-34
6	SDPn1	26-34
7	SDP1_Drain	28-34
8	SDPp2	26-34
9	SDPn2	26-34
10	SDP2_Drain	28-34

3.4 Standard USB Type-C Cable Assemblies

Two standard USB Type-C cable assemblies are defined and allowed by this specification. In addition, captive cables are allowed (see Section 3.4.3). Shielding (braid) is required to enclose all the wires in the USB Type-C cable. The shield shall be terminated to the plug metal shells. The shield should be physically connected to the plug metal shell as close to 360° as possible, to control EMC.

3.4.1 USB Full-Featured Type-C Cable Assembly

Figure 3-20 shows a USB Full-Featured Type-C standard cable assembly.

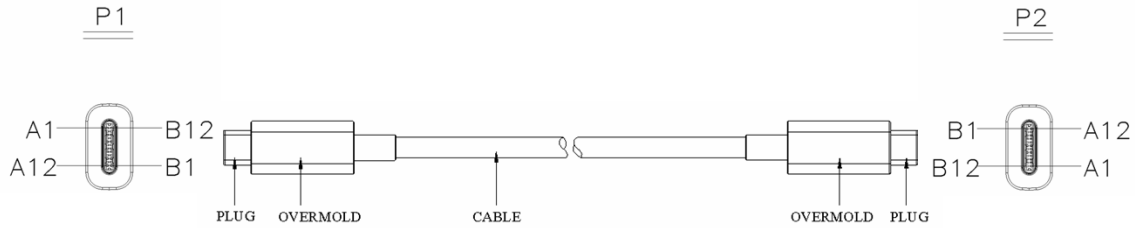

Table 3-10 defines the wire connections for the USB Full-Featured Type-C standard cable assembly.

Table 3-10 USB Full-Featured Type-C Standard Cable Assembly Wiring

USB Type-C Plug #1		Wire		USB Type-C Plug #2	
Pin	Signal Name	Wire Number	Signal Name	Pin	Signal Name
A1, B1, A12, B12	GND	1 [16]	GND_PWRrt1 [GND_PWRrt2]	A1, B1, A12, B12	GND
A4, B4, A9, B9	VBUS	2 [17]	PWR_VBUS1 [PWR_VBUS2]	A4, B4, A9, B9	VBUS
A5	CC	3	CC	A5	CC
B5	VCONN	18	PWR_VCONN (See Section 4.9)	B5	VCONN
A6	Dp1	4	UTP_Dp	A6	Dp1
A7	Dn1	5	UTP_Dn	A7	Dn1
A2	SSTXp1	6	SDPp1	B11	SSRXp1
A3	SSTXn1	7	SDPn1	B10	SSRXn1
B11	SSRXp1	8	SDPp2	A2	SSTXp1
B10	SSRXn1	9	SDPn2	A3	SSTXn1
B2	SSTXp2	10	SDPp3	A11	SSRXp2
B3	SSTXn2	11	SDPn3	A10	SSRXn2
A11	SSRXp2	12	SDPp4	B2	SSTXp2
A10	SSRXn2	13	SDPn4	B3	SSTXn2
A8	SBU1	14	SBU_A	B8	SBU2
B8	SBU2	15	SBU_B	A8	SBU1
Shell	Shield	Braid	Shield	Shell	Shield

Notes:

1. This table is based on the assumption that coaxial wire construction is used for all SDP's and there are no drain wires. The shields of the coaxial wires are connected to the ground pins. If shielded twisted pair is used, then drain wires are needed and shall be connected to the GND pins.
2. Pin B5 (VCONN) of the USB Type-C plug shall be used in electronically marked versions of this cable. See Section 4.9.
3. Contacts B6 and B7 should not be present in the USB Type-C plug.
4. All VBUS pins shall be connected together within the USB Type-C plug. A 10 nF bypass capacitor (minimum voltage rating of 30 V) is required for the VBUS pin in the full-featured cable at each end of the cable. The bypass capacitor should be placed as close as possible to the power supply pad.
5. All GND pins shall be connected together within the USB Type-C plug.

3.4.2 USB 2.0 Type-C Cable Assembly

A [USB 2.0](#) Type-C standard cable assembly has the same form factor shown in Figure 3-20.

Table 3-11 defines the wire connections for the [USB 2.0](#) Type-C standard cable assembly.

Table 3-11 [USB 2.0](#) Type-C Standard Cable Assembly Wiring

USB Type-C Plug #1		Wire		USB Type-C Plug #2	
Pin	Signal Name	Wire Number	Signal Name	Pin	Signal Name
A1, B1, A12, B12	GND	1	GND_PWRrt1	A1, B1, A12, B12	GND
A4, B4, A9, B9	VBUS	2	PWR_VBUS1	A4, B4, A9, B9	VBUS
A5	CC	3	CC	A5	CC
B5	VCONN	18	PWR_VCONN (See Section 4.9)	B5	VCONN
A6	Dp1	4	UTP_Dp	A6	Dp1
A7	Dn1	5	UTP_Dn	A7	Dn1
Shell	Shield	Braid	Shield	Shell	Shield

Notes:

1. Pin B5 (VCONN) of the USB Type-C plug shall be used in electronically marked versions of this cable. See Section 4.9.
2. Contacts B6 and B7 should not be present in the USB Type-C plug.
3. All VBUS pins shall be connected together within the USB Type-C plug. A bypass capacitor is not required for the VBUS pin in the [USB 2.0](#) Type-C cable.
4. All GND pins shall be connected together within the USB Type-C plug.
5. All USB Type-C plug pins that are not listed in this table shall be open (not connected).

3.4.3 USB Type-C Captive Cable Assemblies

A captive cable assembly is a cable assembly that is terminated on one end with a USB Type-C plug and has a vendor-specific connect means (hardwired or custom detachable) on the opposite end. The cable assembly that is hardwired is not detachable from the device.

The assembly wiring for captive USB Type-C cables follow the same wiring assignments as the standard cable assemblies (see Table 3-10 and Table 3-11) with the exception that the hardwired attachment on the device side substitutes for the USB Type-C Plug #2 end.

The CC wire in a captive cable shall be terminated and behave as appropriate to the function of the product to which it is captive (e.g. host or device).

This specification does not define how the hardwired attachment is physically done on the device side.

3.5 Legacy Cable Assemblies

To enable interoperability between USB Type-C-based products and legacy USB products, the following standard legacy cable assemblies are defined. Only the cables defined within this specification are allowed.

For all legacy cable assemblies that support [USB PD](#) BFSK usage, the legacy plug shall be the [USB PD](#) version of the plug and appropriate [USB PD](#) cable marking is required.

3.5.1 USB Type-C to [USB 3.1](#) Standard-A Cable Assembly

Figure 3-21 shows a USB Type-C to [USB 3.1](#) Standard-A cable assembly.

Figure 3-21 USB Type-C to USB 3.1 Standard-A Cable Assembly

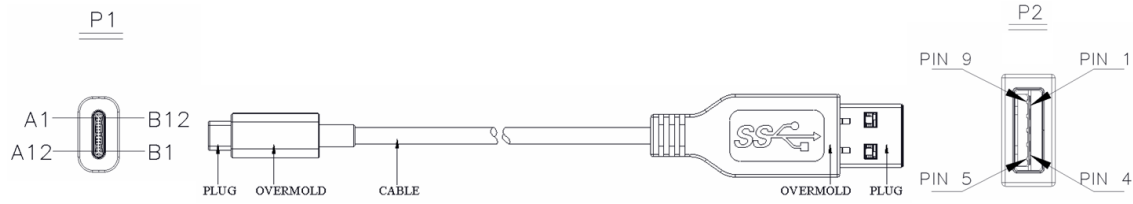

Table 3-12 defines the wire connections for the USB Type-C to [USB 3.1](#) Standard-A cable assembly.

Table 3-12 USB Type-C to [USB 3.1](#) Standard-A Cable Assembly Wiring

USB Type-C Plug		Wire		USB 3.1 Standard-A plug	
Pin	Signal Name	Wire Number	Signal Name	Pin	Signal Name
A1, B1, A12, B12	GND	1 7, 10	GND_PWRrt1 SDP1_Drain, SDP2_Drain	4 7	GND GND_DRAIN
A4, B4, A9, B9	VBUS	2	PWR_VBUS1	1	VBUS
A5	CC				
B5	VCONN				
A6	Dp1	3	UTP_Dp	3	D+
A7	Dn1	4	UTP_Dn	2	D-
A2	SSTXp1	5	SDPp1	6	StdA_SSRX+
A3	SSTXn1	6	SDPn1	5	StdA_SSRX-
B11	SSRXp1	8	SDPp2	9	StdA_SSTX+
B10	SSRXn1	9	SDPn2	8	StdA_SSTX-
Shell	Shield	Braid	Shield	Shell	Shield

Notes:

1. This table is based on the assumption that shielded twisted pair is used for all SDP's and there are drain wires. If coaxial wire construction is used, then no drain wires are present and the shields of the coaxial wires are connected to the ground pins.
2. Pin A5 (CC) of the USB Type-C plug shall be connected to VBUS through a resistor Rp. See Section 4.5.3.2.2 and Table 4-10 for the functional description and value of Rp.
3. Pin B5 (VCONN) of the USB Type-C plug shall be used in electronically marked versions of this cable. See Section 4.9.
4. Contacts B6 and B7 should not be present in the USB Type-C plug.
5. All VBUS pins shall be connected together within the USB Type-C plug. A 10 nF bypass capacitor (minimum voltage rating of 30 V for cable assemblies supporting [USB PD](#)) is required for the VBUS pin in the USB Type-C plug end of the cable. The bypass capacitor should be placed as close as possible to the power supply pad. A bypass capacitor is not required for the VBUS pin in the Standard-A plug.
6. All Ground return pins shall be connected together within the USB Type-C plug.
7. All USB Type-C plug pins that are not listed in this table shall be open (not connected).

3.5.2 USB Type-C to [USB 2.0](#) Standard-A Cable Assembly

Figure 3-22 shows a USB Type-C to [USB 2.0](#) Standard-A cable assembly.

Figure 3-22 USB Type-C to [USB 2.0](#) Standard-A Cable Assembly

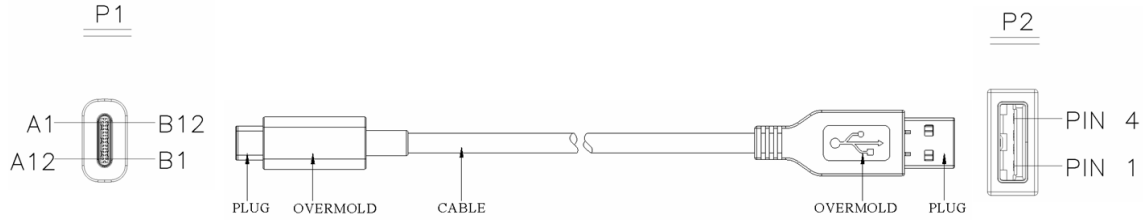

Table 3-13 defines the wire connections for the USB Type-C to [USB 2.0](#) Standard-A cable assembly.

Table 3-13 USB Type-C to [USB 2.0](#) Standard-A Cable Assembly Wiring

USB Type-C Plug		Wire		USB 2.0 Standard-A plug	
Pin	Signal Name	Wire Number	Signal Name	Pin	Signal Name
A1, B1, A12, B12	GND	1	GND_PWRrt1	4	GND
A4, B4, A9, B9	VBUS	2	PWR_VBUS1	1	VBUS
A5	CC				
B5	VCONN				
A6	Dp1	3	UTP_Dp	3	D+
A7	Dn1	4	UTP_Dn	2	D-
Shell	Shield	Braid	Shield	Shell	Shield

Notes:

1. Pin A5 (CC) of the USB Type-C plug shall be connected to VBUS through a resistor R_p . See Section 4.5.3.2.2 and Table 4-10 for the functional description and value of R_p .
2. Pin B5 (VCONN) of the USB Type-C plug shall be used in electronically marked versions of this cable. See Section 4.9.
3. Contacts B6 and B7 should not be present in the USB Type-C plug.
4. All VBUS pins shall be connected together within the USB Type-C plug. Bypass capacitors are not required for the VBUS pins in this cable.
5. All Ground return pins shall be connected together within the USB Type-C plug.
6. All USB Type-C plug pins that are not listed in this table shall be open (not connected).

3.5.3 USB Type-C to [USB 3.1](#) Standard-B Cable Assembly

Figure 3-23 shows a USB Type-C to [USB 3.1](#) Standard-B cable assembly.

Figure 3-23 USB Type-C to [USB 3.1](#) Standard-B Cable Assembly

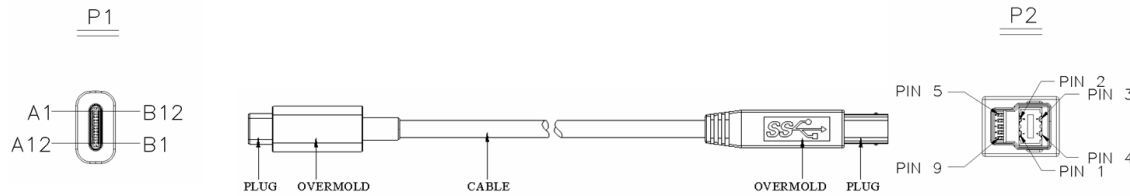

Table 3-14 defines the wire connections for the USB Type-C to [USB 3.1](#) Standard-B cable assembly.

Table 3-14 USB Type-C to [USB 3.1](#) Standard-B Cable Assembly Wiring

USB Type-C Plug		Wire		USB 3.1 Standard-B plug	
Pin	Signal Name	Wire Number	Signal Name	Pin	Signal Name
A1, B1, A12, B12	GND	1 7, 10	GND_PWRrt1 SDP1_Drain, SDP2_Drain	4 7	GND GND_DRAIN
A4, B4, A9, B9	VBUS	2	PWR_VBUS1	1	VBUS
A5	CC				
B5	VCONN				
A6	Dp1	3	UTP_Dp	3	D+
A7	Dn1	4	UTP_Dn	2	D-
A2	SSTXp1	5	SDPp1	9	StdB_SSRX+
A3	SSTXn1	6	SDPn1	8	StdB_SSRX-
B11	SSRXp1	8	SDPp2	6	StdB_SSTX+
B10	SSRXn1	9	SDPn2	5	StdB_SSTX-
Shell	Shield	Braid	Shield	Shell	Shield

Notes:

1. Pin A5 (CC) of the USB Type-C plug shall be connected to GND through a resistor R_d . See Section 4.5.3.2.1 and Table 4-11 for the functional description and value of R_d .
2. Pin B5 (VCONN) of the USB Type-C plug shall be used in electronically marked versions of this cable. See Section 4.9.
3. This table is based on the assumption that shielded twisted pair is used for all SDP's and there are drain wires. If coaxial wire construction is used, then no drain wires are present and the shields of the coaxial wires are connected to the ground pins.
4. Contacts B6 and B7 should not be present in the USB Type-C plug.
5. All VBUS pins shall be connected together within the USB Type-C plug. A 10 nF bypass capacitor (minimum voltage rating of 30 V for cable assemblies supporting [USB PD](#)) is required for the VBUS pin in the USB Type-C plug end of the cable. The bypass capacitor should be placed as close as possible to the power supply pad. A bypass capacitor is not required for the VBUS pin in the Standard-B plug.
6. All Ground return pins shall be connected together within the USB Type-C plug.
7. All USB Type-C plug pins that are not listed in this table shall be open (not connected).

3.5.4 USB Type-C to [USB 2.0](#) Standard-B Cable Assembly

Figure 3-24 shows a USB Type-C to [USB 2.0](#) Standard-B cable assembly.

Figure 3-24 USB Type-C to [USB 2.0](#) Standard-B Cable Assembly

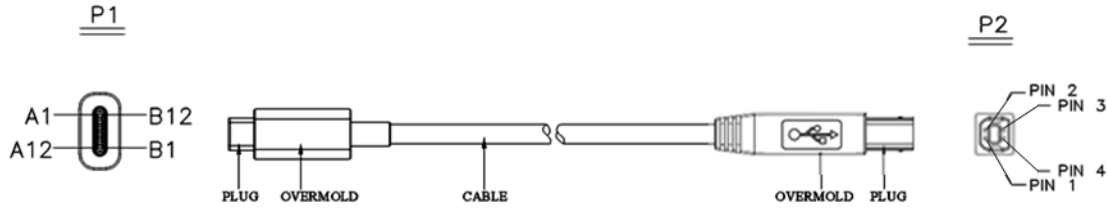

Table 3-15 defines the wire connections for the USB Type-C to [USB 2.0](#) Standard-B cable assembly.

Table 3-15 USB Type-C to [USB 2.0](#) Standard-B Cable Assembly Wiring

USB Type-C Plug		Wire		USB 2.0 Standard-B plug	
Pin	Signal Name	Wire Number	Signal Name	Pin	Signal Name
A1, B1, A12, B12	GND	1	GND_PWRrt1	4	GND
A4, B4, A9, B9	VBUS	2	PWR_VBUS1	1	VBUS
A5	CC				
B5	VCONN				
A6	Dp1	3	UTP_Dp	3	D+
A7	Dn1	4	UTP_Dn	2	D-
Shell	Shield	Braid	Shield	Shell	Shield

Notes:

1. Pin A5 (CC) of the USB Type-C plug shall be connected to GND through a resistor R_d . See Section 4.5.3.2.1 and Table 4-11 for the functional description and value of R_d .
2. Pin B5 (VCONN) of the USB Type-C plug shall be used in electronically marked versions of this cable. See Section 4.9.
3. Contacts B6 and B7 should not be present in the USB Type-C plug.
4. All VBUS pins shall be connected together within the USB Type-C plug. Bypass capacitors are not required for the VBUS pins in this cable.
5. All Ground return pins shall be connected together within the USB Type-C plug.
6. All USB Type-C plug pins that are not listed in this table shall be open (not connected).

3.5.5 USB Type-C to [USB 2.0](#) Mini-B Cable Assembly

Figure 3-25 shows a USB Type-C to [USB 2.0](#) Mini-B cable assembly.

Figure 3-25 USB Type-C to [USB 2.0](#) Mini-B Cable Assembly

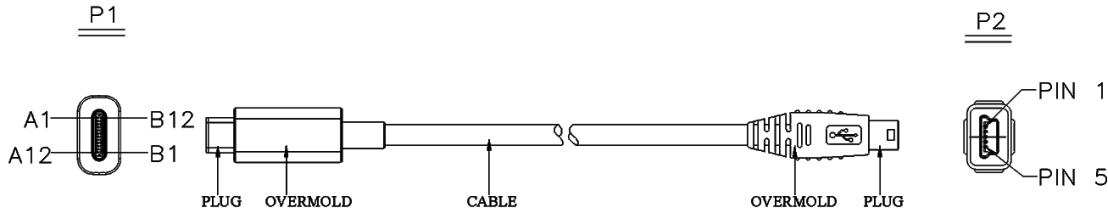

Table 3-16 defines the wire connections for the USB Type-C to [USB 2.0](#) Mini-B cable assembly.

Table 3-16 USB Type-C to [USB 2.0](#) Mini-B Cable Assembly Wiring

USB Type-C Plug		Wire		USB 2.0 Mini-B plug	
Pin	Signal Name	Wire Number	Signal Name	Pin	Signal Name
A1, B1, A12, B12	GND	1	GND_PWRrt1	5	GND
A4, B4, A9, B9	VBUS	2	PWR_VBUS1	1	VBUS
A5	CC				
A6	Dp1	3	UTP_Dp	3	D+
A7	Dn1	4	UTP_Dn	2	D-
				4	ID
Shell	Shield	Braid	Shield	Shell	Shield

Notes:

1. Pin A5 of the USB Type-C plug shall be connected to GND through a resistor R_d . See Section 4.5.3.2.1 and Table 4-11 for the functional description and value of R_d .
2. Contacts B6 and B7 should not be present in the USB Type-C plug.
3. All VBUS pins shall be connected together within the USB Type-C plug. Bypass capacitors are not required for the VBUS pins in this cable.
4. All Ground return pins shall be connected together within the USB Type-C plug.
5. Pin 4 (ID) of the [USB 2.0](#) Mini-B plug shall be terminated as defined in the applicable specification for the cable type.
6. All USB Type-C plug pins that are not listed in this table shall be open (not connected).

3.5.6 USB Type-C to [USB 3.1](#) Micro-B Cable Assembly

Figure 3-26 shows a USB Type-C to [USB 3.1](#) Micro-B cable assembly.

Figure 3-26 USB Type-C to [USB 3.1](#) Micro-B Cable Assembly

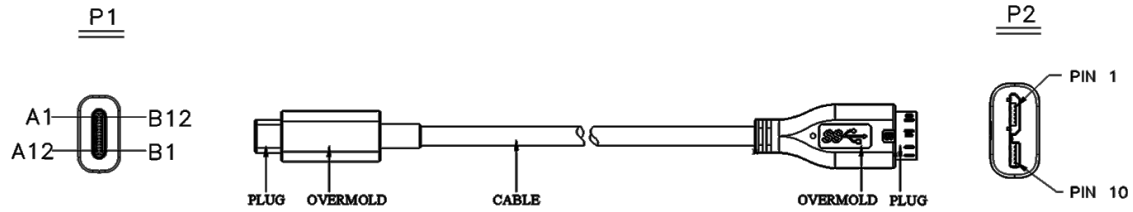

Table 3-17 defines the wire connections for the USB Type-C to [USB 3.1](#) Micro-B cable assembly.

Table 3-17 USB Type-C to [USB 3.1](#) Micro-B Cable Assembly Wiring

USB Type-C Plug		Wire		USB 3.1 Micro-B plug	
Pin	Signal Name	Wire Number	Signal Name	Pin	Signal Name
A1, B1, A12, B12	GND	1 7, 10	GND_PWRrt1 SDP1_Drain, SDP2_Drain	5 8	GND GND_DRAIN
A4, B4, A9, B9	VBUS	2	PWR_VBUS1	1	VBUS
A5	CC				
B5	VCONN				
A6	Dp1	3	UTP_Dp	3	D+
A7	Dn1	4	UTP_Dn	2	D-
A2	SSTXp1	5	SDPp1	10	MicB_SSRX+
A3	SSTXn1	6	SDPn1	9	MicB_SSRX-
B11	SSRXp1	8	SDPp2	7	MicB_SSTX+
B10	SSRXn1	9	SDPn2	6	MicB_SSTX-
				4	ID
Shell	Shield	Braid	Shield	Shell	Shield

Notes:

1. Pin A5 (CC) of the USB Type-C plug shall be connected to GND through a resistor R_d . See Section 4.5.3.2.1 and Table 4-11 for the functional description and value of R_d .
2. Pin B5 (VCONN) of the USB Type-C plug shall be used in electronically marked versions of this cable. See Section 4.9.
3. This table is based on the assumption that shielded twisted pair is used for all SDP's and there are drain wires. If coaxial wire construction is used, then no drain wires are present and the shields of the coaxial wires are connected to the ground pins.
4. Contacts B6 and B7 should not be present in the USB Type-C plug.
5. All VBUS pins shall be connected together within the USB Type-C plug. A 10 nF bypass capacitor (minimum voltage rating of 30 V for cable assemblies supporting [USB PD](#)) is required for the VBUS pin in the USB Type-C plug end of the cable. The bypass capacitor should be placed as close as possible to the power supply pad. A bypass capacitor is not required for the VBUS pin in the Micro-B plug.
6. All Ground return pins shall be connected together within the USB Type-C plug.
7. Pin 4 (ID) of the [USB 3.1](#) Micro-B plug shall be terminated as defined in the applicable specification for the cable type.
8. All USB Type-C plug pins that are not listed in this table shall be open (not connected).

3.5.7 USB Type-C to [USB 2.0](#) Micro-B Cable Assembly

Figure 3-27 shows a USB Type-C to [USB 2.0](#) Micro-B cable assembly.

Figure 3-27 USB Type-C to [USB 2.0](#) Micro-B Cable Assembly

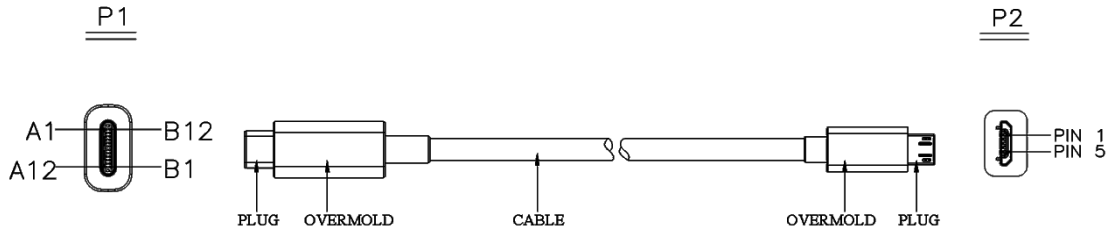

Table 3-18 defines the wire connections for the USB Type-C to [USB 2.0](#) Micro-B cable assembly.

Table 3-18 USB Type-C to [USB 2.0](#) Micro-B Cable Assembly Wiring

USB Type-C Plug		Wire		USB 2.0 Micro-B plug	
Pin	Signal Name	Wire Number	Signal Name	Pin	Signal Name
A1, B1, A12, B12	GND	1	GND_PWRrt1	5	GND
A4, B4, A9, B9	VBUS	2	PWR_VBUS1	1	VBUS
A5	CC				
B5	VCONN				
A6	Dp1	3	UTP_Dp	3	D+
A7	Dn1	4	UTP_Dn	2	D-
				4	ID
Shell	Shield	Braid	Shield	Shell	Shield

Notes:

- Pin A5 (CC) of the USB Type-C plug shall be connected to GND through a resistor R_d . See Section 4.5.3.2.1 and Table 4-11 for the functional description and value of R_d .
- Pin B5 (VCONN) of the USB Type-C plug shall be used in electronically marked versions of this cable. See Section 4.9.
- Contacts B6 and B7 should not be present in the USB Type-C plug.
- All VBUS pins shall be connected together within the USB Type-C plug. Bypass capacitors are not required for the VBUS pins in this cable.
- All Ground return pins shall be connected together within the USB Type-C plug.
- Pin 4 (ID) of the [USB 2.0](#) Micro-B plug shall be terminated as defined in the applicable specification for the cable type.
- All USB Type-C plug pins that are not listed in this table shall be open (not connected).

3.6 Legacy Adapter Assemblies

To enable interoperability between USB Type-C-based products and legacy USB products, the following standard legacy adapter assemblies are defined. Only the adapter assemblies defined in this specification are allowed.

3.6.1 USB Type-C to [USB 3.1](#) Standard-A Receptacle Adapter Assembly

Figure 3-28 shows a USB Type-C to [USB 3.1](#) Standard-A receptacle adapter assembly. This cable assembly is defined for direct connect to a USB device (e.g., a thumb drive). System functionality of using this adaptor assembly together with another USB cable assembly is not guaranteed.

Figure 3-28 USB Type-C to [USB 3.1](#) Standard-A Receptacle Adapter Assembly

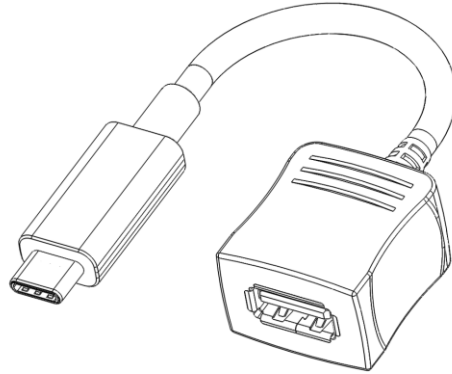

Table 3-19 defines the wire connections for the USB Type-C to [USB 3.1](#) Standard-A receptacle adapter assembly.

Table 3-19 USB Type-C to [USB 3.1](#) Standard-A Receptacle Adapter Assembly Wiring

USB Type-C Plug		USB 3.1 Standard-A receptacle	
Pin	Signal Name	Pin	Signal Name
A1, B1, A12, B12	GND	4 7	GND GND_DRAIN
A4, B4, A9, B9	VBUS	1	VBUS
A5	CC		
B5	VCONN		
A6	Dp1	3	D+
A7	Dn1	2	D-
A2	SSTXp1	9	StdA_SSTX+
A3	SSTXn1	8	StdA_SSTX-
B11	SSRXp1	6	StdA_SSRX+
B10	SSRXn1	5	StdA_SSRX-
Shell	Shield	Shell	Shield

Notes:

1. Pin A5 (CC) of the USB Type-C plug shall be connected to GND through a resistor R_d . See Section 4.5.3.2.1 and Table 4-11 for the functional description and value of R_d .
2. Pin B5 (VCONN) of the USB Type-C plug shall be used in electronically marked versions of this adapter. See Section 4.9.
3. This table is based on the assumption that shielded twisted pair is used for all SDP's and there are drain wires. If coaxial wire construction is used, then no drain wires are present and the shields of the coaxial wires are connected to the ground pins.
4. Contacts B6 and B7 should not be present in the USB Type-C plug.
5. All VBUS pins shall be connected together within the USB Type-C plug. A 10 nF bypass capacitor is required for the VBUS pin in the USB Type-C plug end of the cable. The bypass capacitor should be placed as close as possible to the power supply pad. A bypass capacitor is not required for the VBUS pin in the Standard-A receptacle.
6. All Ground return pins shall be connected together within the USB Type-C plug.
7. All USB Type-C plug pins that are not listed in this table shall be open (not connected).

3.6.2 USB Type-C to [USB 2.0](#) Micro-B Receptacle Adapter Assembly

Figure 3-28 shows a USB Type-C to [USB 2.0](#) Micro-B receptacle adapter assembly.

Figure 3-29 USB Type-C to [USB 2.0](#) Micro-B Receptacle Adapter Assembly

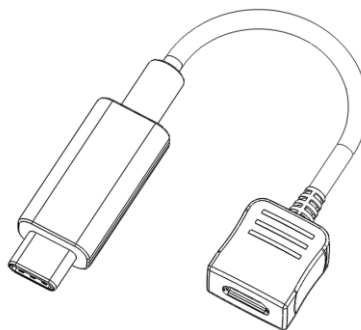

Table 3-19 defines the wire connections for the USB Type-C to [USB 2.0](#) Micro-B receptacle adapter assembly.

Table 3-20 USB Type-C to [USB 2.0](#) Micro-B Receptacle Adapter Assembly Wiring

USB Type-C Plug		USB 2.0 Micro-B receptacle	
Pin	Signal Name	Pin	Signal Name
A1, B1, A12, B12	GND	5	GND
A4, B4, A9, B9	VBUS	1	VBUS
A5	CC		
A6	Dp1	3	D+
A7	Dn1	2	D-
		4	ID
Shell	Shield	Shell	Shield

Notes:

1. Pin A5 (CC) of the USB Type-C plug shall be connected to VBUS through a resistor Rp. See Section 4.5.3.2.2 and Table 4-10 for the functional description and value of Rp.
2. Contacts B6 and B7 should not be present in the USB Type-C plug.
3. All VBUS pins shall be connected together within the USB Type-C plug. Bypass capacitors are not required for the VBUS pins at the Micro-B receptacle end of this cable.
4. All Ground return pins shall be connected together within the USB Type-C plug.
5. All USB Type-C plug pins that are not listed in this table shall be open (not connected).

3.7 Electrical Characteristics

This section defines the USB Type-C raw cable, connector, and cable assembly electrical requirements, including signal integrity, shielding effectiveness, and DC requirements. Chapter 4 defines additional requirements regarding functional signal definition, host/device discovery and configuration, and power delivery.

Unless otherwise specified, all measurements are made at a temperature of 15° to 35° C, a relative humidity of 25% to 85%, and an atmospheric pressure of 86 to 106 kPa and all S-parameters are normalized with an 85 Ω differential impedance.

3.7.1 Raw Cable (Informative)

Informative raw cable electrical performance targets are provided to help cable assembly manufacturers manage the procurement of raw cable. These targets are not part of the USB Type-C compliance requirements. The normative requirement is that the cable assembly meets the performance characteristics specified in Sections 3.7.3, 3.7.4, and 3.7.5.

The differential characteristic impedance for shielded differential pairs is recommended to be 90 Ω ± 5 Ω. The single-ended characteristic impedance of coaxial wires is recommended to be 45 Ω ± 3 Ω. The impedance should be evaluated using a 200 ps (10%-90%) rise time; a faster rise time is not necessary for raw cable since it will make cable test fixture discontinuities more prominent.

3.7.1.1 Intra-Pair Skew (Informative)

The intra-pair skew for a differential pair is recommended to be less than 10 ps/m. It should be measured with a Time Domain Transmission (TDT) in a differential mode using a 200 ps (10%-90%) rise time with a crossing at 50% of the input voltage.

3.7.1.2 Differential Insertion Loss (Informative)

Cable loss depends on wire gauges, plating and dielectric materials. Table 3-21 and Table 3-22 show examples of differential insertion losses.

Table 3-21 Differential Insertion Loss Examples for USB SuperSpeed with Twisted Pair Construction

Frequency	34AWG	32AWG	30AWG	28AWG
0.625 GHz	-1.8 dB/m	-1.4 dB/m	-1.2 dB/m	-1.0 dB/m
1.25 GHz	-2.5 dB/m	-2.0 dB/m	-1.7 dB/m	-1.4 dB/m
2.50 GHz	-3.7 dB/m	-2.9 dB/m	-2.5 dB/m	-2.1 dB/m
5.00 GHz	-5.5 dB/m	-4.5 dB/m	-3.9 dB/m	-3.1 dB/m
7.50 GHz	-7.0 dB/m	-5.9 dB/m	-5.0 dB/m	-4.1 dB/m
10.00 GHz	-8.4 dB/m	-7.2 dB/m	-6.1 dB/m	-4.8 dB/m
12.50 GHz	-9.5 dB/m	-8.2 dB/m	-7.3 dB/m	-5.5 dB/m
15.00 GHz	-11.0 dB/m	-9.5 dB/m	-8.7 dB/m	-6.5 dB/m

Table 3-22 Differential Insertion Loss Examples for USB SuperSpeed with Coaxial Construction

Frequency	34AWG	32AWG	30AWG	28AWG
0.625 GHz	-1.8 dB/m	-1.5 dB/m	-1.2 dB/m	-1.0 dB/m
1.25 GHz	-2.8 dB/m	-2.2 dB/m	-1.8 dB/m	-1.3 dB/m
2.50 GHz	-4.2 dB/m	-3.4 dB/m	-2.7 dB/m	-1.9 dB/m
5.00 GHz	-6.1 dB/m	-4.9 dB/m	-4.0 dB/m	-3.1 dB/m
7.50 GHz	-7.6 dB/m	-6.5 dB/m	-5.2 dB/m	-4.2 dB/m
10.0 GHz	-8.8 dB/m	-7.6 dB/m	-6.1 dB/m	-4.9 dB/m
12.5 GHz	-9.9 dB/m	-8.6 dB/m	-7.1 dB/m	-5.7 dB/m
15.0 GHz	-12.1 dB/m	-10.9 dB/m	-9.0 dB/m	-6.5 dB/m

3.7.2 Mated Connector (Normative)

The mated connector as defined in this specification for USB Type-C consists of a receptacle mounted on a PCB, representing how the receptacle is used in a product, and a test plug also mounted on a PCB (paddle card) without cable. This is illustrated in Figure 3-30. Note that the test plug is used in host/device TX/RX testing also.

Figure 3-30 Illustration of USB Type-C Mated Connector

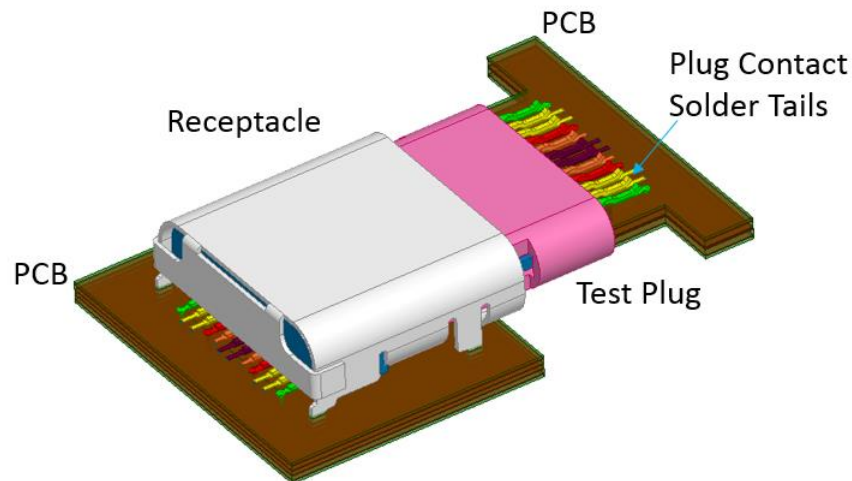

3.7.2.1 Differential Impedance (Informative)

The mated connector impedance target is specified to minimize reflection from the connector. The differential impedance of a mated connector should be within $85 \Omega \pm 9 \Omega$, as seen from a 40 ps (20%-80%) rise time. The impedance profile of a mated connector should fall within the limits shown in Figure 3-31.

Figure 3-31 Recommended Impedance Limits of a USB Type-C Mated Connector

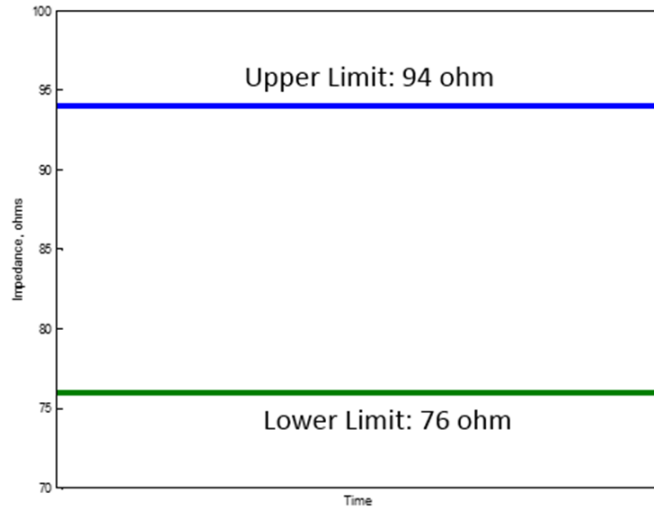

The PCB stack up, lead geometry, and solder pad geometry should be modeled in 3D field-solver to optimize electrical performance. Example ground voids under signal pads are shown in Figure 3-32 based on pad geometry, mounting type, and PCB stack-up shown.

Figure 3-32 Recommended Ground Void Dimensions for USB Type-C Receptacle

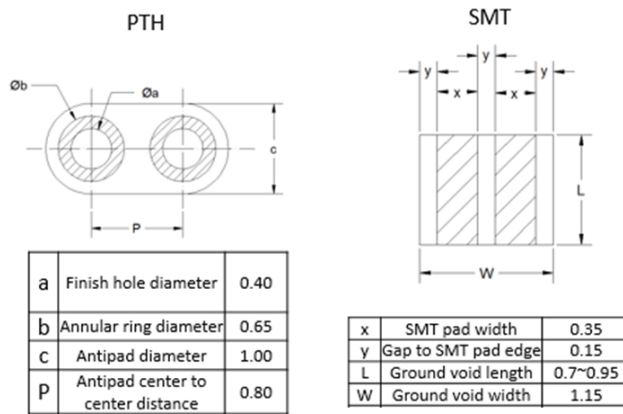

Unit: mm

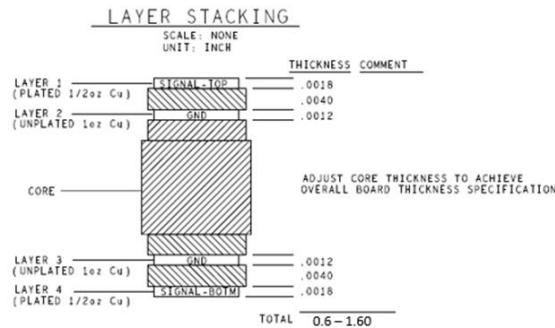

3.7.2.2 Differential Insertion Loss (Informative)

The differential insertion loss measures the differential signal energy transmitted through the mated connector. Figure 3-33 shows the differential insertion loss limit, which is defined by the following vertices: (100 MHz, -0.25 dB), (2.5 GHz, -0.35 dB), (5 GHz, -0.45 dB), (10 GHz, -0.75 dB) and (15 GHz, -1.85 dB).

Figure 3-33 Recommended Differential Insertion Loss Limits

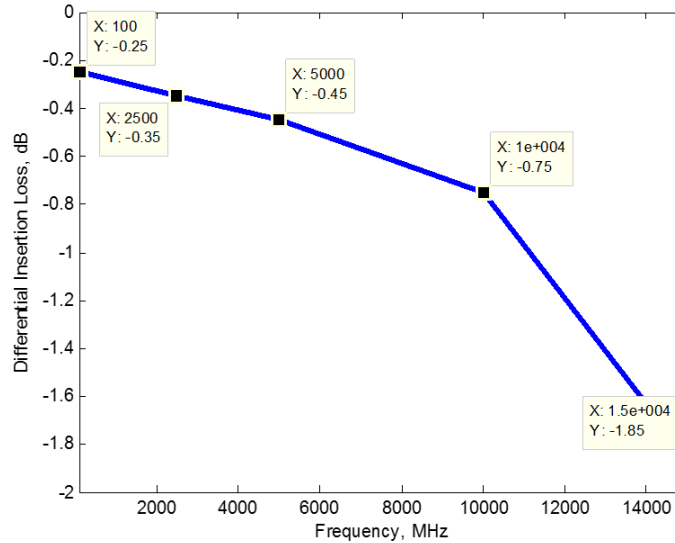

3.7.2.3 Differential Return Loss (Informative)

The differential return loss measures the differential signal reflection from the mated connector. Figure 3-34 shows the differential return loss limits as defined by the following vertices: (100 MHz, -20 dB), (5 GHz, -20 dB), (10 GHz, -13 dB), and (15 GHz, -6 dB).

Figure 3-34 Recommended Differential Return Loss Limits

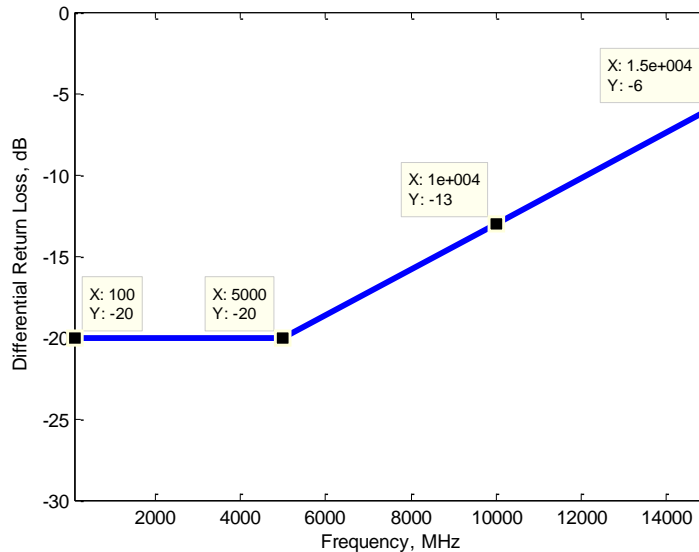

3.7.2.4 Differential Near-End and Far-End Crosstalk between SuperSpeed Pairs (Informative)

The differential crosstalk measures the unwanted coupling between differential pairs. Both near-end crosstalk and far-end crosstalk for mated connector pairs are specified, as shown in Figure 3-35. The recommended limit is defined by the following vertices: (100 MHz, -40 dB), (5 GHz, -40 dB), (10 GHz, -36 dB), and (15 GHz, -30 dB).

Figure 3-35 Recommended Differential Crosstalk Limits between SuperSpeed Pairs

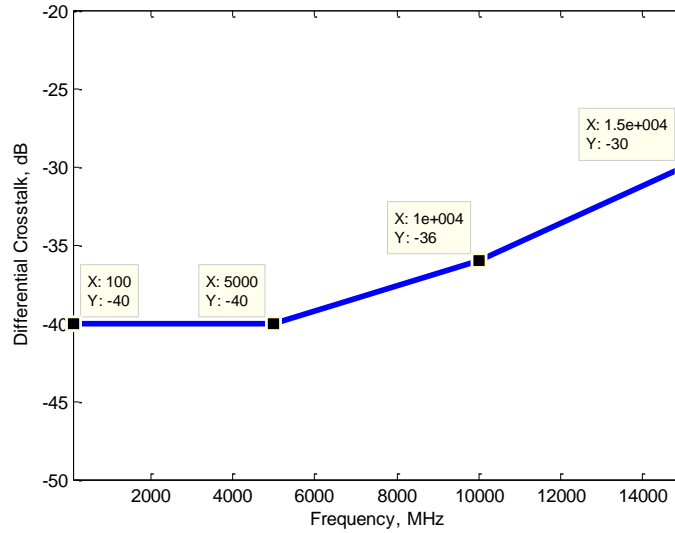

3.7.2.5 Differential Crosstalk between D+/D- and SuperSpeed Pairs (Informative)

The differential near-end and far-end crosstalk between the D+/D- pair and the SuperSpeed pairs in mated connectors should be managed not to exceed the limit shown in Figure 3-36; the limit is defined by the following points: (100 MHz, -40 dB), (5 GHz, -40 dB), and (7.5 GHz, -36 dB).

Figure 3-36 Recommended Differential Near-End and Far-End Crosstalk Limits between D+/D- Pair and SuperSpeed Pairs

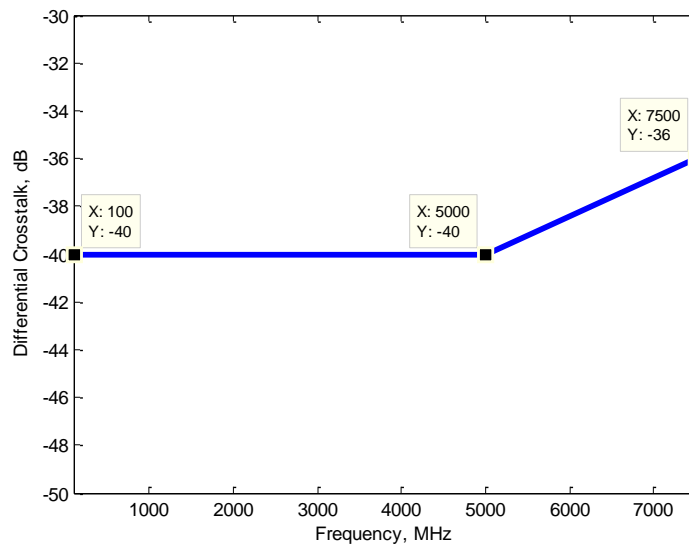

3.7.2.6 Differential-to-Common-Mode Conversion (Informative)

Common mode noise is related to EMC performance. Figure 3-37 illustrates the recommended mode conversion limits for mated connector pairs as defined by the following vertices: (100 MHz, -30 dB), (6 GHz, -30 dB), and (10 GHz, -25 dB).

Figure 3-37 Recommended Limits for Differential-to-Common-Mode Conversion

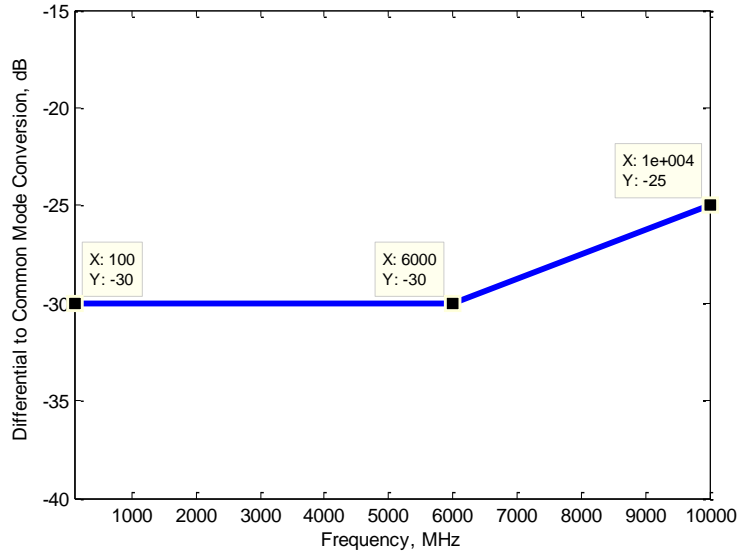

3.7.3 USB Type-C to Type-C Passive Cable Assemblies (Normative)

A USB Type-C to Type-C cable assembly shall be tested using a test fixture with the receptacle tongue fabricated in the test fixture. This is illustrated in Figure 3-38. The USB Type-C receptacles are not present in the test fixture. Hosts and devices should account for the additional signal degradation the receptacle introduces.

The requirements are for the entire signal path of the cable assembly mated with the fixture PCB tongues, not including lead-in PCB traces. As illustrated in Figure 3-38, the measurement is between TP1 (test point 1) and TP2 (test point 2). Refer to documentation located at [Cable Assembly and Connector Test Requirements](#) page on the [USB-IF](#) website for a detailed description of a standardized test fixture.

Figure 3-38 Illustration of Test Points for a Mated Cable Assembly

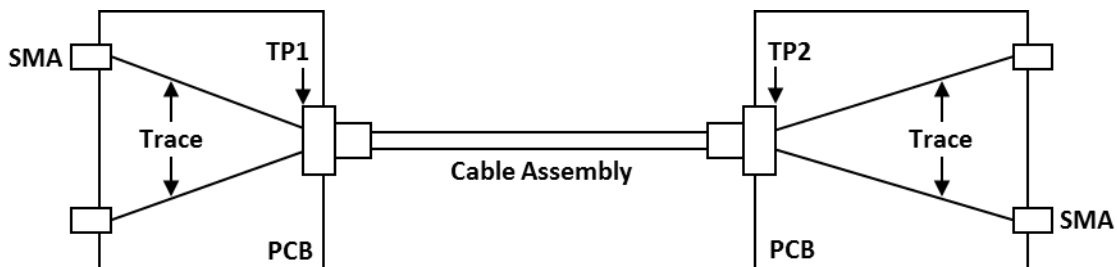

The cable assembly requirements are divided into informative and normative requirements. The informative requirements are provided as design targets for cable assembly manufacturers. The normative requirements are the pass/failure criteria for cable assembly compliance.

3.7.3.1 Recommended USB SuperSpeed Passive Cable Assembly Characteristics

3.7.3.1.1 Differential Insertion Loss (Informative)

Figure 3-39 shows the differential insertion loss limit for a [USB 3.1](#) Gen 2 Type-C cable assembly, which is defined by the following vertices: (100 MHz, -2 dB), (2.5 GHz, -4 dB), (5.0 GHz, -6 dB), (10 GHz, -11 dB) and (15 GHz, -20 dB).

Figure 3-39 Recommended Differential Insertion Loss Requirement

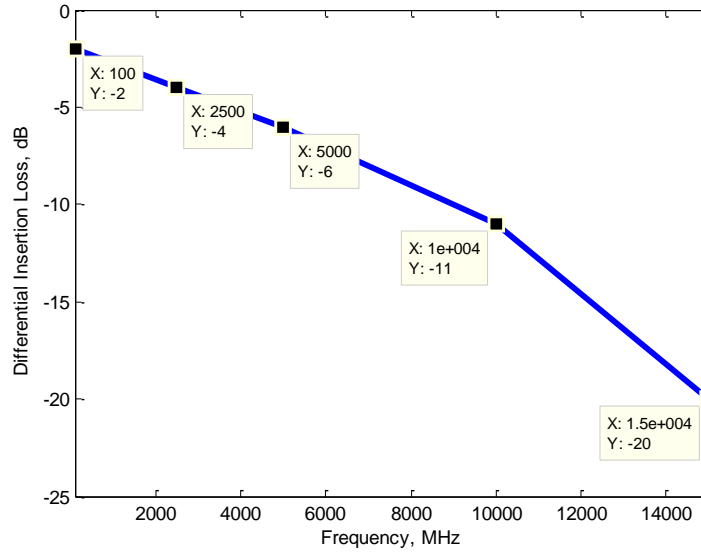

3.7.3.1.2 Differential Return Loss (Informative)

Figure 3-40 shows the differential return loss limit, which is defined by the following points: (100 MHz, -18 dB), (5 GHz, -18 dB), (10 GHz, -12 dB), and (15 GHz, -5 dB).

Figure 3-40 Recommended Differential Return Loss Requirement

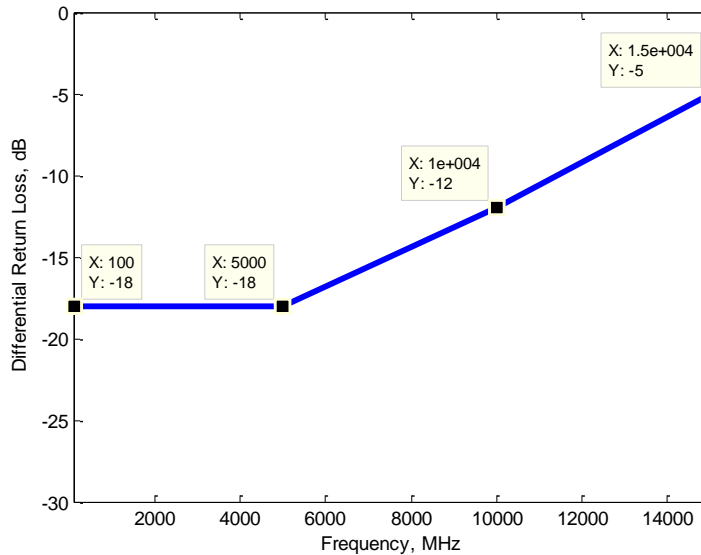

3.7.3.1.3 Differential Near-End and Far-End Crosstalk between SuperSpeed Pairs (Informative)

Both the near-end crosstalk (DDNEXT) and far-end crosstalk (DDFEXT) are specified, as shown in Figure 3-41. The DDNEXT/DDFEXT limits are defined by the following vertices: (100 MHz, -37 dB), (5 GHz, -37 dB), (10 GHz, -32 dB), and (15 GHz, -25 dB).

Figure 3-41 Recommended Differential Crosstalk Requirement

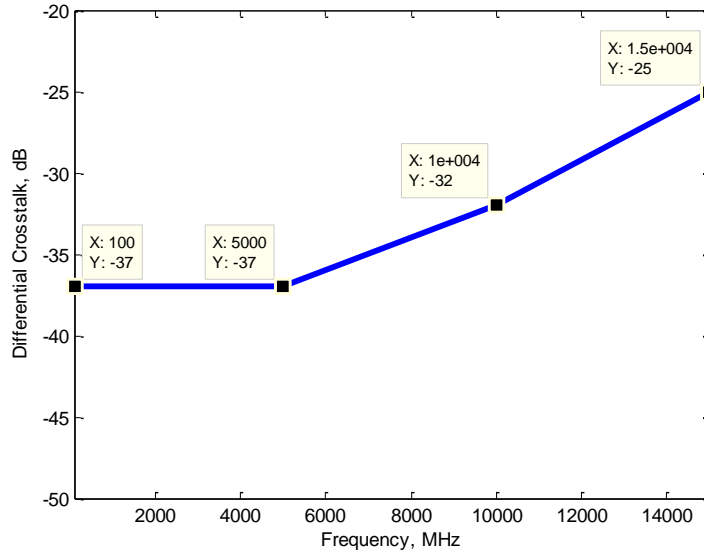

3.7.3.1.4 Differential Crosstalk between USB D+/D- and USB SuperSpeed Pairs (Informative)

The differential near-end and far-end crosstalk between the USB D+/D- pair and the USB SuperSpeed pairs should be managed not to exceed the limits shown in Figure 3-42. The limits are defined by the following points: (100 MHz, -35 dB), (5 GHz, -35 dB), and (7.5 GHz, -30 dB).

Figure 3-42 Recommended Differential Near-End and Far-End Crosstalk Requirement between USB D+/D- Pair and USB SuperSpeed Pair

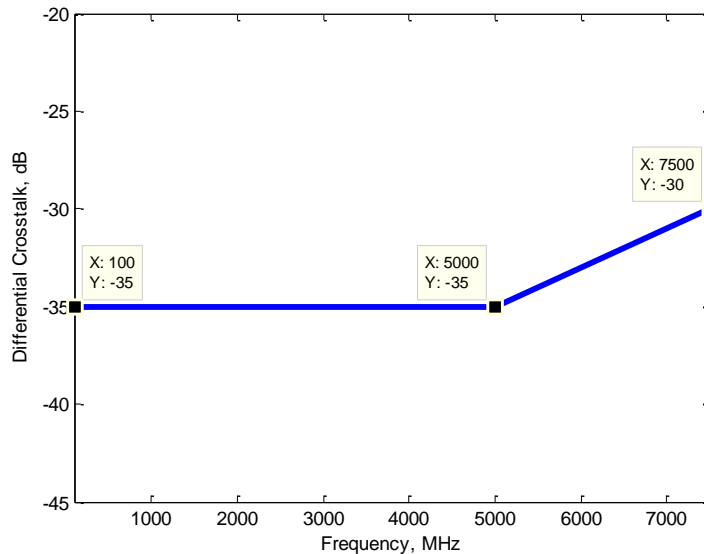

3.7.3.2 Normative SuperSpeed Passive Cable Assembly Requirements

The integrated parameters are used for cable assembly compliance (except for insertion loss and differential-to-common-mode conversion) to avoid potential rejection of a functioning cable assembly that may fail the traditional S-parameters spec at a few frequencies.

3.7.3.2.1 Insertion Loss Fit at Nyquist Frequencies (Normative)

The insertion loss fit at Nyquist frequency measures the attenuation of the cable assembly. To obtain the insertion loss fit at Nyquist frequency, the measured cable assembly differential insertion loss is fitted with a smooth function. A standard fitting algorithm and tool shall be used to extract the insertion loss fit at Nyquist frequencies. Refer to documentation located at [Cable Assembly and Connector Test Requirements](#) page on the [USB-IF](#) website for a more detailed description about insertion loss fit. Figure 3-43 illustrates an example of a measured cable assembly insertion loss fitted with a smooth function; the insertion loss fit at the Nyquist frequency of USB SuperSpeed Gen 2 (5.0 GHz) is -5.8 dB.

Figure 3-43 Illustration of Insertion Loss Fit at Nyquist Frequency

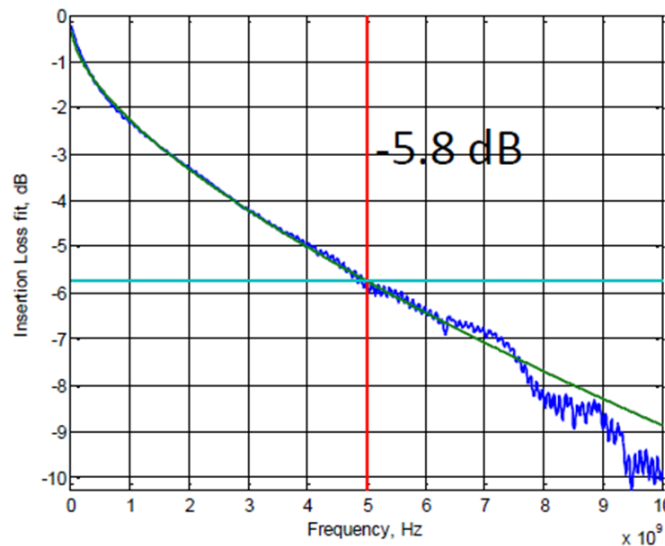

The insertion loss fit at Nyquist frequency (ILfitatNq) shall meet the following requirements:

- ≥ -4 dB at 2.5 GHz,
- ≥ -6 dB at 5 GHz, and
- ≥ -11 dB at 10 GHz.

2.5 GHz, 5.0 GHz and 10 GHz are the Nyquist frequencies for USB SuperSpeed Gen 1, USB SuperSpeed Gen 2, and a possible future 20 Gbps USB data rate, respectively.

The USB SuperSpeed Gen 1-only Type-C to Type-C cable assembly is allowed by this specification and shall comply with the following insertion loss fit at Nyquist frequency requirements:

- ≥ -7.0 dB at 2.5 GHz, and
- > -12 dB at 5 GHz.

This insertion fit at Nyquist frequency allows the USB SuperSpeed Gen 1-only Type-C to Type-C cable assembly to achieve an overall length of approximately 2 meters.

3.7.3.2.2 Integrated Multi-reflection (Normative)

The insertion loss deviation, ILD, is defined as

$$ILD(f) = IL(f) - IL_{fit}(f)$$

It measures the ripple of the insertion loss, caused by multiple reflections inside the cable assembly (mated with the fixture). The integration of $ILD(f)$ is called the integrated multi-reflection (IMR):

$$IMR = dB \left(\sqrt{\frac{\int_0^{f_{max}} |ILD(f)|^2 |Vin(f)|^2 df}{\int_0^{f_{max}} |Vin(f)|^2 df}} \right)$$

where $f_{max} = 15$ GHz and $Vin(f)$ is the input trapezoidal pulse spectrum, defined in Figure 3-44.

Figure 3-44 Input Pulse Spectrum

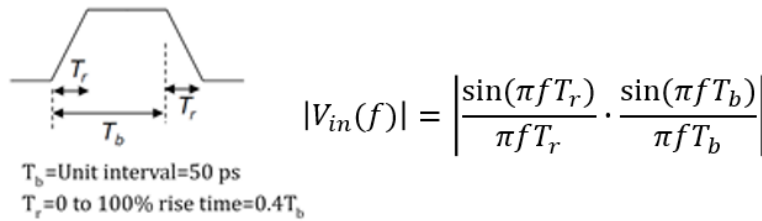

IMR has dependency on $IL_{fitatNq}$. More IMR may be tolerated when $IL_{fitatNq}$ decreases. The IMR limit is specified as a function of $IL_{fitatNq}$:

$$IMR \leq 0.126 \cdot IL_{fitatNq}^2 + 3.024 \cdot IL_{fitatNq} - 29.353.$$

This is plotted in Figure 3-45.

Figure 3-45 IMR Limit as Function of ILfitatNq

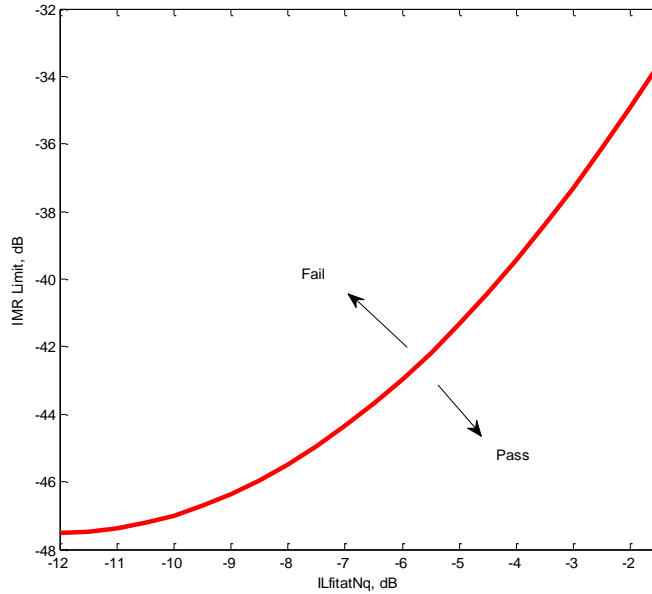

3.7.3.2.3 Integrated Crosstalk between SuperSpeed Pairs (Normative)

The integrated crosstalk between all USB SuperSpeed pairs is calculated with the equations below:

$$\begin{aligned}
 & INEXT \\
 & = dB \left(\sqrt{\frac{\int_0^{f_{max}} |Vin(f)|^2 (|NEXT(f)|^2 + 0.125^2 \cdot |C2D(f)|^2) df + |Vdd(f)|^2 |NEXTd(f)|^2 df}{\int_0^{f_{max}} |Vin(f)|^2 df}} \right) \\
 & IFEXT \\
 & = dB \left(\sqrt{\frac{\int_0^{f_{max}} |Vin(f)|^2 (|FEXT(f)|^2 + 0.125^2 \cdot |C2D(f)|^2) df + |Vdd(f)|^2 |FEXTd(f)|^2 df}{\int_0^{f_{max}} |Vin(f)|^2 df}} \right)
 \end{aligned}$$

where $NEXT(f)$, $FEXT(f)$, and $C2D(f)$ are the measured near-end and far-end crosstalk between USB SuperSpeed pairs, and the common-mode-to-differential conversion, respectively. The factor of 0.125^2 accounts for the assumption that the common mode amplitude is 12.5% of the differential amplitude. $NEXTd(f)$ and $FEXTd(f)$ are, respectively, the near-end and far-end crosstalk from the D+/D- pair to SuperSpeed pairs. $Vdd(f)$ is the input pulse spectrum evaluated using the equation in Figure 3-44 with $T_b=2.08$ ns.

The integration shall be done for each NEXT and FEXT between USB SuperSpeed pairs located at A2, A3 to B10, B11 and B2, B3 to A10, A11 (See Figure 2-2). Coupling between other combinations of USB SuperSpeed pairs is comparatively lower. The largest values of INEXT and IFEXT shall meet the following requirements:

- $INEXT \leq -40$ dB,
- $IFEXT \leq -40$ dB.

3.7.3.2.4 Integrated Return Loss (Normative)

The integrated return loss (IRL) manages the reflection between the cable assembly and the rest of the system (host and device). It is defined as:

$$IRL = dB \left(\sqrt{\frac{\int_0^{f_{max}} |Vin(f)|^2 |SDD21(f)|^2 (|SDD11(f)|^2 + |SDD22(f)|^2) df}{\int_0^{f_{max}} |Vin(f)|^2 df}} \right)$$

where $SDD21(f)$ is the measured cable assembly differential insertion loss, $SDD11(f)$ and $SDD22(f)$ are the measured cable assembly return losses on the left and right sides, respectively, of a differential pair.

The IRL also has a strong dependency on $IL_{fitatNq}$, and its limit is specified as a function of $IL_{fitatNq}$:

$$IRL \leq 0.046 \cdot IL_{fitatNq}^2 + 1.812 \cdot IL_{fitatNq} - 15.825$$

It is shown in Figure 3-46.

Figure 3-46 IRL Limit as Function of $IL_{fitatNq}$

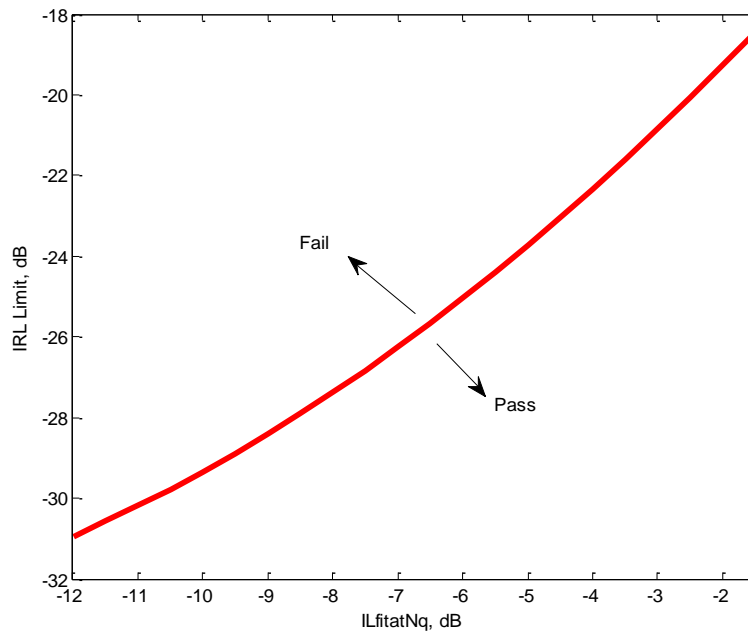

3.7.3.2.5 Differential-to-Common-Mode Conversion (Normative)

The differential-to-common-mode conversion is specified to control the injection of common mode noise from the cable assembly into the host or device. Figure 3-47 illustrates the differential-to-common mode conversion (SCD12/SCD21) requirement. A mated cable assembly passes if its SCD12/SCD21 is less than or equal to -20 dB from 100 MHz to 10 GHz.

Figure 3-47 Differential-to-Common-Mode Conversion Requirement

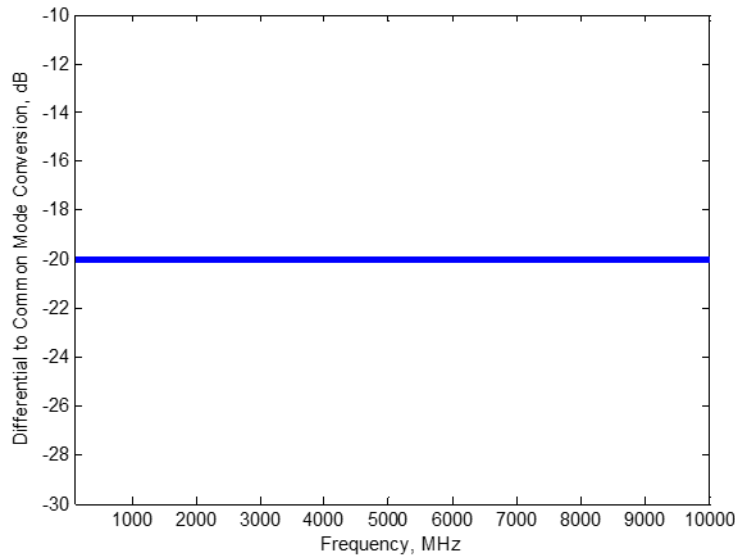

3.7.3.3 Low-Speed Signal Requirements (Normative)

This section specifies the low speed signal requirements including the impedance for CC and SBU wires and the coupling among CC, USB D+/D-, VBUS and SBU.

CC and SBU wires shall have a characteristic impedance of 32 Ω to 53 Ω . These wires may be unshielded or shielded.

Coupling or crosstalk, both near-end and far-end, among the low speed signals shall be controlled. Table 3-23 shows the matrix of couplings specified.

Table 3-23 Coupling Matrix for Low Speed Signals

Coupling Matrix	D+/D- (DF)	VBUS	SBU_B/SBU_A
CC	FF, CT	FF, CT	FF
D+/D- (DF)	N/A	FF, CT	FF
SBU_A/SBU_B	FF	FF	FF

DF: Differential; FF: Full-featured cable; CT: Charge-through cable (including USB 2.0 function).

3.7.3.3.1 CC to USB D+/D- (Normative)

The differential coupling between the CC and D+/D- shall be below the limit shown in Figure 3-48. The limit is -40 dB at 1 MHz with a slope of 20 dB per decade until the slope intercepts a horizontal line at -18 dB, then continuing at -18 dB to 100 MHz.

Figure 3-48 Requirement for Differential Coupling between CC and D+/D-

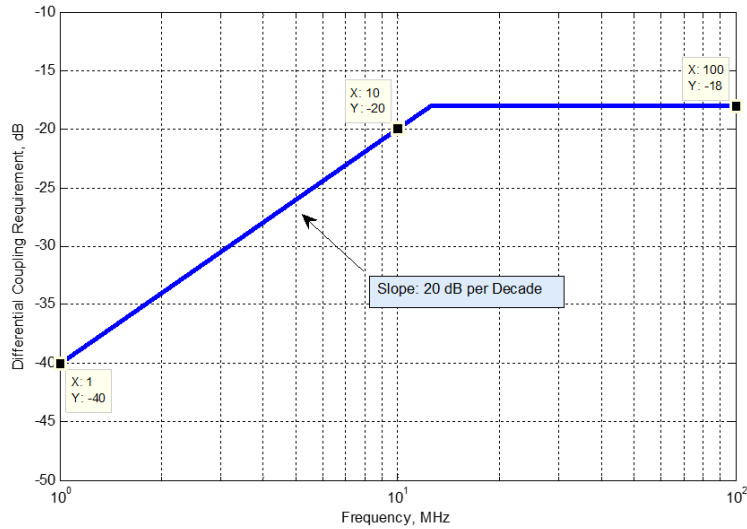

3.7.3.3.2 Vbus Coupling to SBU_A/SBU_B, CC, and USB D+/D- (Normative)

The single-ended coupling between VBUS and SBU_A/SBU_B and between VBUS and CC shall be less than the limits shown in Figure 3-49. The limit is defined by the vertices of (1 MHz, -40 dB), (10 MHz, -20 dB), and (100 MHz, -20 dB).

Figure 3-49 Requirement for Single-ended Coupling between VBUS and SBU_A/SBU_B and between VBUS and CC

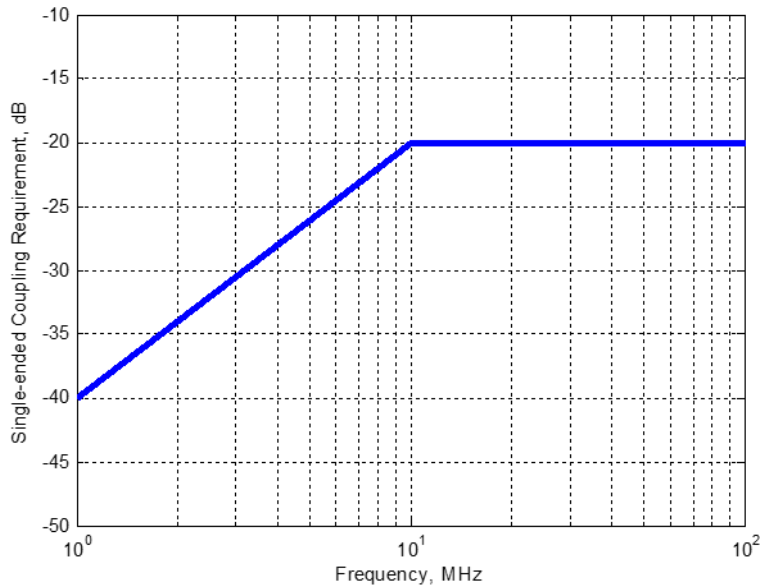

The differential coupling between VBUS and USB D+/D- is specified in Figure 3-50. The limit is defined by the following vertices: (1 MHz, -40 dB), (30 MHz, -40 dB), and (100 MHz, -30 dB).

Figure 3-50 Requirement for Differential Coupling between VBUS and D+/D-

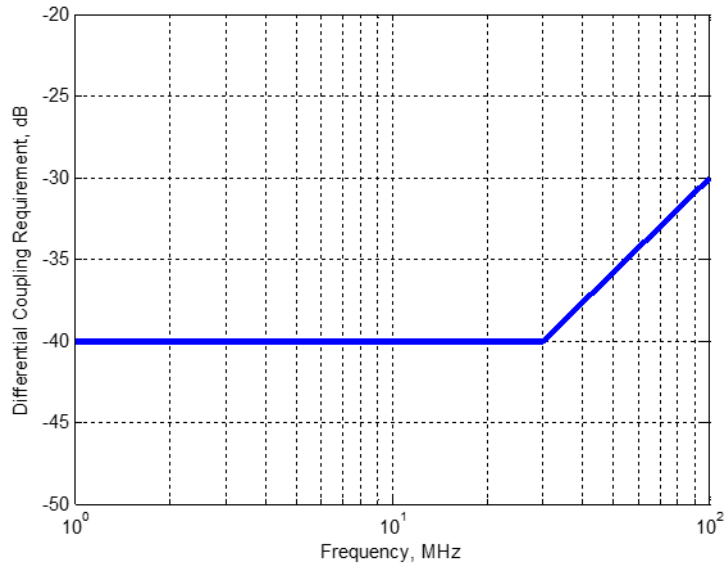

The loop inductance of the VBUS line shall be controlled to limit the noises caused by load release on the VBUS line. The maximum loop inductance allowed is 900 nH.

3.7.3.3.3 Coupling between SBU_A/SBU_B and CC, SBU_A/SBU_B and USB D+/D-, and SBU_A and SBU_B (Normative)

The single-ended coupling between SBU_A/SBU_B and CC and between SBU_A and SBU_B shall be less than the limit shown in Figure 3-51. The limit is defined with the vertices of (1 MHz, -46 dB), (10 MHz, -26 dB), (11.2 MHz, -25 dB), and (500 MHz, -25 dB).

The differential coupling between SBU_A/SBU_B and USB D+/D- shall comply with the requirement shown in Figure 3-51.

Figure 3-51 Requirement for Single-Ended Coupling between SBU_A/SBU_B and CC, and for Differential Coupling between SBU_A/SBU_B and USB D+/D-

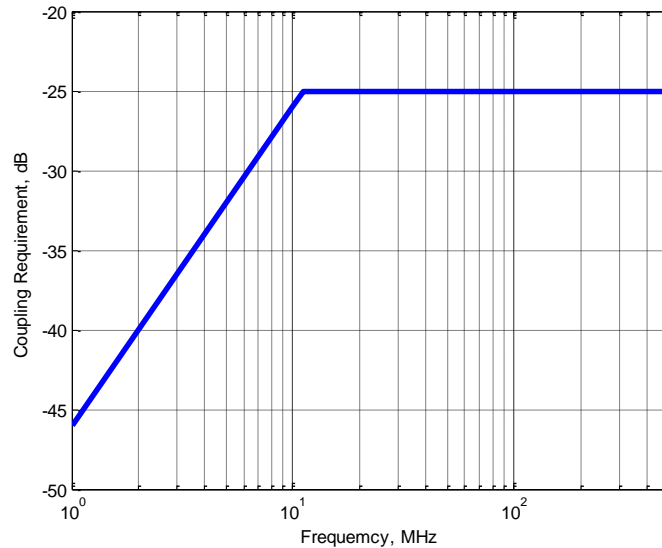

3.7.3.4 USB D+/D– Signal Requirements (Normative)

The USB D+/D– lines of the USB Type-C to Type-C cable assembly shall meet the requirements defined in Table 3-24.

Table 3-24 USB D+/D– Signal Integrity Requirements

Items	Descriptions and Procedures	Requirements
Differential Impedance	EIA 364-108 This test ensures that the D+/D– lines of the cable assembly have the proper impedance. For the entire cable assembly.	75 ohms min and 105 ohms max. 400 ps rise time (20%-80%).
Propagation Delay	EIA 364-103 The purpose of the test is to verify the end-to-end propagation of the D+/D– lines of the cable assembly.	20 ns max. 400 ps rise time (20%-80%).
Intra-pair Skew	EIA 364 – 103 This test ensures that the signal on both the D+ and D– lines of cable assembly arrive at the receiver at the same time.	100 ps max. 400 ps rise time (20%-80%).
D+/D– Pair Attenuation	EIA 364 – 101 This test ensures the D+/D– pair of a cable assembly is able to provide adequate signal strength to the receiver in order to maintain a low error rate.	≥ –1.02 dB @ 50 MHz ≥ –1.43 dB @ 100 MHz ≥ –2.40 dB @ 200 MHz ≥ –4.35 dB @ 400 MHz

3.7.4 USB Type-C to Legacy Cable Assemblies (Normative)

The USB Type-C to legacy cable assemblies may support [USB 2.0](#) only or [USB 3.1](#) Gen 2; [USB 3.1](#) Gen 1-only Type-C to legacy cable assemblies are not allowed.

3.7.4.1 USB 2.0-only Cable Assemblies (Normative)

The [USB 2.0](#)-only Type-C to legacy USB cable assemblies include:

- USB Type-C plug to [USB 2.0](#) Standard-A plug
- USB Type-C plug to [USB 2.0](#) Standard-B plug
- USB Type-C plug to [USB 2.0](#) Micro-B plug
- USB Type-C plug to [USB 2.0](#) Mini-B plug

The USB D+/D– signal integrity requirements are specified in Table 3-25.

Table 3-25 USB D+/D- Signal Integrity Requirements for USB Type-C to Legacy USB Cable Assemblies

Items	Descriptions and Procedures	Requirements
Differential Impedance	EIA 364-108 This test ensures that the D+/D- lines of the cable assembly have the proper impedance. For the entire cable assembly.	75 ohms min and 105 ohms max. 400 ps rise time (20%-80%).
Propagation Delay	EIA 364-103 The purpose of the test is to verify the end-to-end propagation of the D+/D- lines of the cable assembly.	10 ns max for USB Type-C to Micro-B cable assembly; 20 ns max for all other USB Type-C to legacy USB cable assemblies. 400 ps rise time (20%-80%).
Intra-pair Skew	EIA 364 - 103 This test ensures that the signal on both the D+ and D- lines of cable assembly arrive at the receiver at the same time.	100 ps max. 400 ps rise time (20%-80%).
D+/D- Pair Attenuation	EIA 364 - 101 This test ensures the D+/D- pair of a cable assembly is able to provide adequate signal strength to the receiver in order to maintain a low error rate.	≥ -1.02 dB @ 50 MHz ≥ -1.43 dB @ 100 MHz ≥ -2.40 dB @ 200 MHz ≥ -4.35 dB @ 400 MHz

3.7.4.2 [USB 3.1](#) Gen 2 Cable Assemblies (Normative)

The USB Type-C to [USB 3.1](#) Gen 2 legacy cable assemblies include:

- USB Type-C plug to [USB 3.1](#) Standard-A plug
- USB Type-C plug to [USB 3.1](#) Standard-B plug
- USB Type-C plug to [USB 3.1](#) Micro-B plug

The informative design targets for these cables are provided in Table 3-26.

Table 3-26 Design Targets for USB Type-C to [USB 3.1](#) Gen 2 Legacy Cable Assemblies (Informative)

Items	Design Targets
Differential Impedance	76 ohms min and 96 ohms max. 40 ps rise time (20%-80%).
Differential Insertion Loss	≥ -2 dB @ 100 MHz ≥ -4 dB @ 2.5 GHz, except for the USB Type-C plug to USB 3.1 Standard-A plug cable assembly which is ≥ -3.5 dB @ 2.5 GHz -6.0 dB max @ 5.0 GHz
Differential NEXT between SuperSpeed Pairs	≤ -34 dB to 5 GHz
Differential NEXT and FEXT between D+/D- and SuperSpeed Pairs	≤ -30 dB to 5 GHz

The normative requirements include the USB D+/D- signaling as specified in Table 3-25, and the USB SuperSpeed parameters specified in Table 3-27.

Table 3-27 USB Type-C to [USB 3.1](#) Gen 2 Legacy Cable Assembly Signal Integrity Requirements (Normative)

Items	Descriptions and Procedures	Requirements
Differential Insertion Loss Fit at Nyquist Frequencies (ILfitatNq)	ILfitatNq is evaluated at both the SuperSpeed Gen 1 and Gen 2 Nyquist frequencies.	≥ -4 dB @ 2.5 GHz, except for the USB Type-C plug to USB 3.1 Standard-A plug cable assembly which is ≥ -3.5 dB @ 2.5 GHz ≥ -6.0 dB at 5.0 GHz
Integrated Differential Multi-reflection (IMR)	$dB \left(\sqrt{\frac{\int_0^{f_{max}} ILD(f) ^2 Vin(f) ^2 df}{\int_0^{f_{max}} Vin(f) ^2 df}} \right)$	$\leq 0.126 \cdot ILfitatNq^2 + 3.024 \cdot ILfitatNq - 27.353$. See Figure 3-52.
Integrated Differential Crosstalk on SuperSpeed (ISSXT)	$dB \left(\sqrt{\frac{\int_0^{f_{max}} (Vin(f) ^2 NEXTs(f) ^2 + Vdd(f) ^2 NEXTd(f) ^2) df}{\int_0^{f_{max}} Vin(f) ^2 df}} \right)$ <p>where: <i>NEXTs</i> = NEXT between SuperSpeed pairs <i>NEXTd</i> = NEXT between D+/D- and SuperSpeed pairs <i>Vdd(f)</i> = Input pulse spectrum on D+/D- pair, evaluated using equation shown in Figure 3-44 with Tb (UI) = 2.08 ns.</p>	≤ -38 dB
Integrated Differential Crosstalk on D+/D- (IDDXT)	$dB \left(\sqrt{\frac{\int_0^{f_{max}} (Vin(f) ^2 NEXT(f) ^2 + Vin(f) ^2 FEXT(f) ^2) df}{\int_0^{f_{max}} Vin(f) ^2 df}} \right)$ <p>where: <i>NEXT</i> = Near-end crosstalk from SuperSpeed to D+/D- <i>FEXT</i> = Far-end crosstalk from SuperSpeed to D+/D- <i>fmax</i> = 7.5 GHz</p>	≤ -34 dB
Integrated Return Loss (IRL)	$dB \left(\sqrt{\frac{\int_0^{f_{max}} Vin(f) ^2 (SDD21(f) ^2 (SDD11(f) ^2 + SDD22(f) ^2)) df}{\int_0^{f_{max}} Vin(f) ^2 df}} \right)$	$\leq 0.046 \cdot ILfitatNq^2 + 1.812 \cdot ILfitatNq - 14.825$. See Figure 3-53.

Note: *fmax* = 10 GHz (unless otherwise specified); *Vin(f)* is defined in Figure 3-44 with Tb (UI) = 100 ps; and *Vdd(f)* is also defined in Figure 3-44 with Tb (UI) = 2.08 ns.

Figure 3-52 IMR Limit as Function of ILfitatNq for USB Type-C to Legacy Cable Assembly

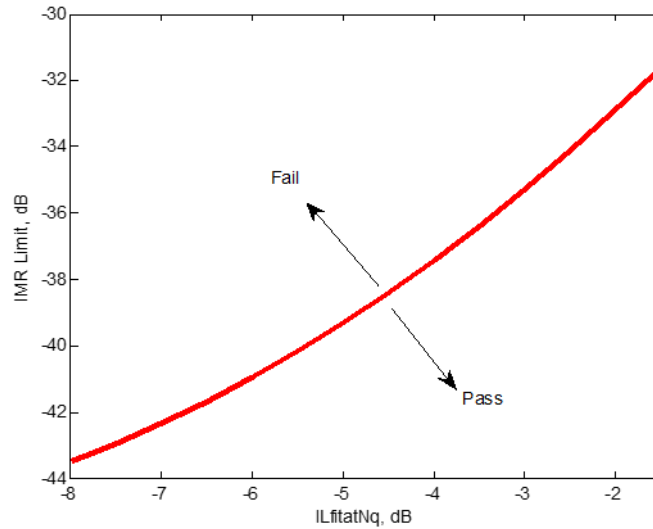
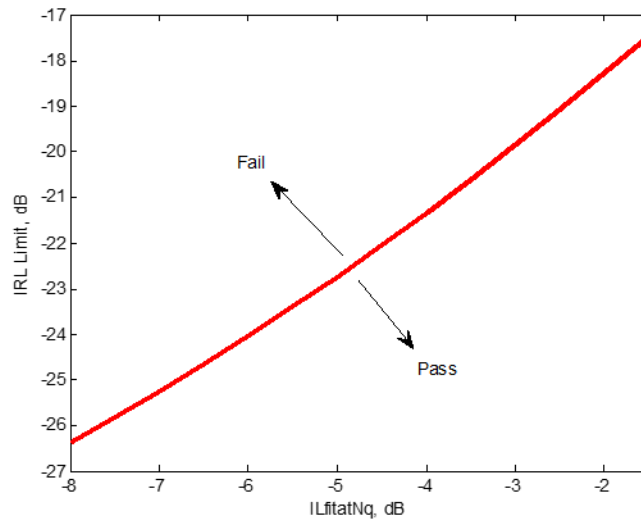

Figure 3-53 IRL Limit as Function of ILfitatNq for USB Type-C to Legacy Cable Assembly



3.7.5 USB Type-C to USB Legacy Adapter Assemblies (Normative)

Only the following standard legacy adapter assemblies are defined:

- [USB 2.0](#) Type-C plug to [USB 2.0](#) Micro-B receptacle
- USB Full-Featured Type-C plug to [USB 3.1](#) Standard-A receptacle

3.7.5.1 USB 2.0 Type-C Plug to [USB 2.0](#) Micro-B Receptacle Adapter Assembly (Normative)

This adapter assembly supports only the [USB 2.0](#) signaling. It shall not exceed 150 mm total length, measured from end to end. Table 3-28 defines the electrical requirements.

Table 3-28 USB D+/D- Signal Integrity Requirements for USB Type-C to Legacy USB Adapter Assemblies (Normative)

Items	Descriptions and Procedures	Requirements
Differential Impedance	EIA 364-108 This test ensures that the D+/D- lines of the adapter assembly have the proper impedance. For the entire adaptor assembly.	75 ohms min and 105 ohms max. 400 ps rise time (20%-80%).
Intra-pair Skew	EIA 364 - 103 This test ensures that the signal on both the D+ and D- lines of adapter assembly arrive at the receiver at the same time.	20 ps max. 400 ps rise time (20%-80%).
Differential Insertion Loss	EIA 364 - 101 This test ensures the D+/D- pair of an adapter assembly can provide adequate signal strength to the receiver.	-0.7 dB max @ 400 MHz

3.7.5.2 USB Full-Featured Type-C Plug to [USB 3.1](#) Standard-A Receptacle Adapter Assembly (Normative)

The USB Full-Featured Type-C plug to [USB 3.1](#) Standard-A receptacle adapter assembly is intended to be used with a direct-attach device (e.g., USB thumb drive). A system is not guaranteed to function when using an adapter assembly together with a Standard USB cable assembly.

To minimize the impact of the adapter assembly to system signal integrity, the adapter assembly should meet the informative design targets in Table 3-29.

Table 3-29 Design Targets for USB Type-C to [USB 3.1](#) Standard-A Adapter Assemblies (Informative)

Items	Design Targets
Differential Return Loss	≤ -15 dB to 2.5 GHz Normalized with 85 ohms.
Differential Insertion Loss	≥ -2 dB to 2.5 GHz
Differential NEXT between SuperSpeed Pairs	≤ -40 dB to 2.5 GHz
Differential NEXT and FEXT between D+/D- and SuperSpeed Pairs	≤ -30 dB to 2.5 GHz

The normative requirements for the adapter assembly are defined in Table 3-28 and Table 3-30. The adapter assembly total length is limited to 150 mm max.

Table 3-30 USB Type-C to [USB 3.1](#) Standard-A Receptacle Adapter Assembly Signal Integrity Requirements (Normative)

Items	Descriptions and Procedures	Requirements
Differential Insertion Loss Fit at Nyquist Frequency (ILfitatNq)	ILfitatNq is evaluated at the SuperSpeed Gen 1 Nyquist frequency.	≥ -2 dB at 2.5 GHz
Integrated Differential Multi-reflection (IMR)	$dB \left(\sqrt{\frac{\int_0^{f_{max}} ILD(f) ^2 Vin(f) ^2 df}{\int_0^{f_{max}} Vin(f) ^2 df}} \right)$	≤ -38 dB
Integrated Differential Crosstalk on SuperSpeed (ISSXT)	$dB \left(\sqrt{\frac{\int_0^{f_{max}} (Vin(f) ^2 NEXTs(f) ^2 + Vdd(f) ^2 NEXTd(f) ^2) df}{\int_0^{f_{max}} Vin(f) ^2 df}} \right)$ where: NEXTs = NEXT between SuperSpeed pairs NEXTd = NEXT between D+/D- and SuperSpeed pairs Vdd(f) = Input pulse spectrum on D+/D- pair, evaluated using equation shown in Figure 3-44 with Tb (UI) = 2.08 ns.	≤ -38 dB
Integrated Differential Crosstalk on D+/D- (IDDXT)	$dB \left(\sqrt{\frac{\int_0^{f_{max}} (Vin(f) ^2 NEXT(f) ^2 + Vin(f) ^2 FEXT(f) ^2) df}{\int_0^{f_{max}} Vin(f) ^2 df}} \right)$ where: NEXT = Near-end crosstalk from SuperSpeed to D+/D- FEXT = Far-end crosstalk from SuperSpeed to D+/D- f _{max} = 7.5 GHz	≤ -32 dB
Integrated Return Loss (IRL)	$dB \left(\sqrt{\frac{\int_0^{f_{max}} Vin(f) ^2 SDD21(f) ^2 (SDD11(f) ^2 + SDD22(f) ^2) df}{\int_0^{f_{max}} Vin(f) ^2 df}} \right)$	≤ -24 dB

Note: f_{max} = 7.5 GHz; $Vin(f)$ is defined in Figure 3-44 with Tb (UI) = 200 ps; and $Vdd(f)$ is also specified in Figure 3-44 with Tb (UI) = 2.08 ns.

3.7.6 Shielding Effectiveness Requirements (Normative)

The cable assembly shielding effectiveness (SE) test measures the EMI and RFI levels from the cable assembly. To perform the measurement, the cable assembly shall be installed in the cable SE test fixture as shown in Figure 3-54. The coupling factors from the cable to the fixture are characterized with a VNA.

Figure 3-54 Cable Assembly Shielding Effectiveness Testing

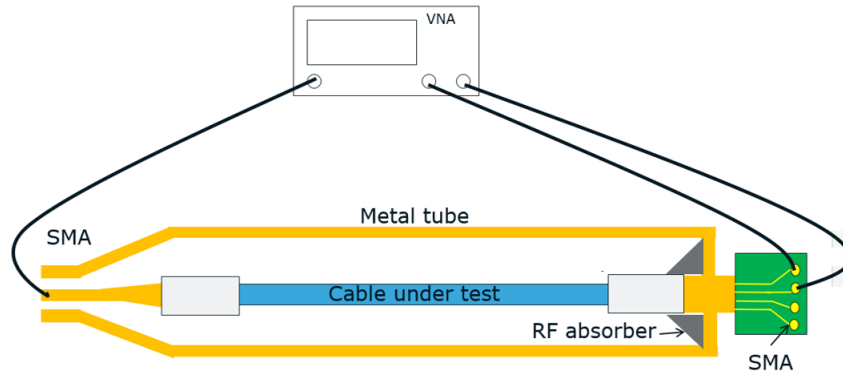

All USB Type-C cable assemblies shall pass the shielding effectiveness test for compliance. The pass/fail criteria for the USB Type-C to USB Type-C cable assemblies is shown in Figure 3-55a while the pass/fail criteria for the USB Type-C to legacy USB cable assemblies is shown in Figure 3-55b. Note that the shielding effectiveness for the frequency band from 4 GHz to 5 GHz is not specified since there is no antenna operating in this frequency range.

Figure 3-55 Shielding Effectiveness Pass/Fail Criteria

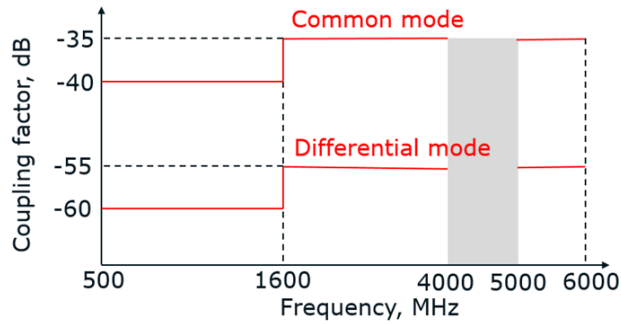

(a) For USB Type-C to USB Type-C Cable Assemblies

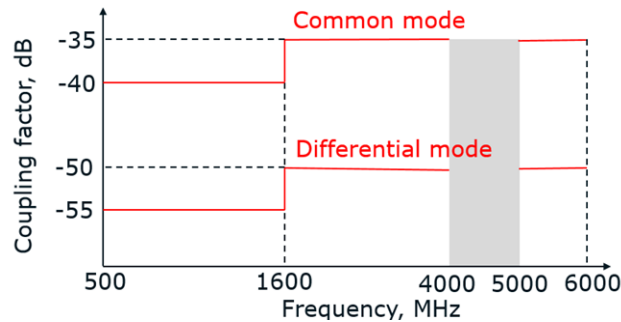

(b) For USB Type-C to legacy USB cable assemblies

3.7.7 DC Electrical Requirements (Normative)

Unless otherwise stated, the tests in this section are performed on mated connector pairs.

3.7.7.1 Low Level Contact Resistance (EIA 364-23B)

The low level contact resistance (LLCR) measurement is made from the solder tail of the receptacle to the soldering point of the plug (including any internal paddle cards, contacts and substrates of the plug and receptacle). See Figure 3-56. The following requirements apply to the power and signal contacts:

- 40 m Ω (Max) initial for VBUS, GND and all other contacts.
- Maximum change (delta) of +10 m Ω after environmental stresses.
- Measure at 20 mV (Max) open circuit at 100 mA.

Refer to Section 3.8 for environmental requirements and test sequences.

Figure 3-56 LLCR Measurement Diagram

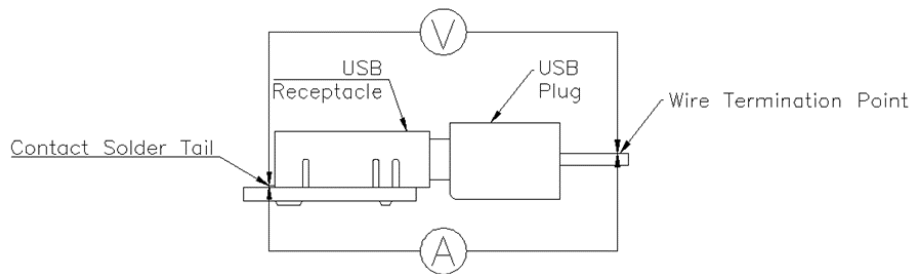

3.7.7.2 Dielectric Strength (EIA 364-20)

No breakdown shall occur when 100 Volts AC (RMS) is applied between adjacent contacts of unmated and mated connectors.

3.7.7.3 Insulation Resistance (EIA 364-21)

A minimum of 100 M Ω insulation resistance is required between adjacent contacts of unmated and mated connectors.

3.7.7.4 Contact Current Rating (EIA 364-70, Method 2)

A current of 5.0 A shall be applied collectively to VBUS pins (i.e., pins A4, A9, B4, and B9) and 1.25 A applied to the VCONN pin (i.e., B5 of the plug connector) with the return path through the corresponding GND pins (i.e., pins A1, A12, B1, and B12). A minimum current of 0.25 A shall also be applied individually to all the other contacts. When the currents are applied to the contacts, the temperature rise shall not exceed 30 °C at any point on the USB Type-C mated plug and receptacle under test, when measured at an ambient temperature of 25 °C.

3.8 Mechanical and Environmental Requirements (Normative)

The requirements in this section apply to all USB Type-C connectors and/or cable assemblies unless otherwise specified. For USB Type-C plug connectors and cable assemblies, the test methods are based on an assumption that the cable exits the overmold in line with mating direction to a USB Type-C receptacle (i.e., straight out the back of the overmold). For USB Type-C plug connectors and cable assemblies with the cable exiting the overmold in a different direction than straight out the back (e.g., right angle to the mating direction), test fixtures and procedures shall be modified as required to accomplish the measurement.

3.8.1 Mechanical Requirements

3.8.1.1 Insertion Force (EIA 364-13)

The initial connector insertion force shall be within the range from 5 N to 20 N at a maximum rate of 12.5 mm (0.492") per minute. This requirement does not apply when the connectors are used in a docking application.

It is recommended to use a non-silicone based lubricant on the latching mechanism to reduce wear. The effects of lubricants should be restricted to insertion and extraction characteristics and should not increase the resistance of the mated connection.

3.8.1.2 Extraction Force (EIA 364-13)

The connector extraction force shall be within the range of 8 N to 20 N before and after the specified insertion/extraction or durability cycles (at a maximum rate of 12.5 mm (0.492") per minute). This requirement does not apply when the connectors are used in a mechanical docking application.

It is recommended to use a non-silicone based lubricant on the latching mechanism to reduce wear. The effects of lubricants should be restricted to insertion and extraction characteristics and should not increase the resistance of the mated connection.

3.8.1.3 Durability or Insertion/Extraction Cycles (EIA 364-09)

The durability rating shall be 10,000 cycles minimum for the USB Type-C connector family. The durability test shall be done at a maximum rate of 200 cycles per hour and no physical damage to any part of the connector and cable assembly shall occur.

3.8.1.4 Cable Flexing (EIA 364-41, Condition 1)

No physical damage or discontinuity over 1ms during flexing shall occur to the cable assembly with Dimension X = 3.7 times the cable diameter and 100 cycles in each of two planes.

3.8.1.5 Cable Pull-Out (EIA 364-38, Method A)

No physical damage to the cable assembly shall occur when it is subjected to a 40 N axial load for a minimum of 1 minute while clamping one end of the cable plug.

3.8.1.6 4-Axis Continuity Test

The USB Type-C connector family shall be tested for continuity under stress using the test configurations shown in Figure 3-57. Plugs shall be supplied in a cable assembly with a representative overmold. A USB Type-C receptacle shall be mounted on a 2-layer printed circuit board (PCB) between 0.8 mm and 1.0 mm thickness. The PCB shall be clamped on either side of the receptacle no further than 5 mm away from the solder tails. The PCB shall initially be placed in a horizontal plane, and an 8 N tensile force shall be applied to the cable in a downward direction, perpendicular to the axis of insertion, for a period of at least 10 seconds. For receptacle designs that do not have a full length shell, the test shall be done with the connector and associated hardware mounted as in the final product configuration.

The continuity across each contact shall be measured throughout the application of the tensile force. Each non-ground contact shall also be tested to confirm that it does not short to the shell during the stresses. The PCB shall then be rotated 90 degrees such that the cable is still inserted horizontally and the 8 N tensile force shall be applied again in the downward direction and continuity measured as before. This test is repeated for 180 degree and 270 degree rotations. Passing parts shall not exhibit any discontinuities or shorting to the shell greater than 1 μ s duration in any of the four orientations.

One method for measuring the continuity through the contacts is to short all the wires at the end of the cable pigtail and apply a voltage through a pull-up to each of VBUS, USB D+, USB D-, SBU, CC, and USB SuperSpeed pins, with the GND pins connected to ground.

Alternate methods are allowed to verify continuity through all pins.

Figure 3-57 4-Axis Continuity Test

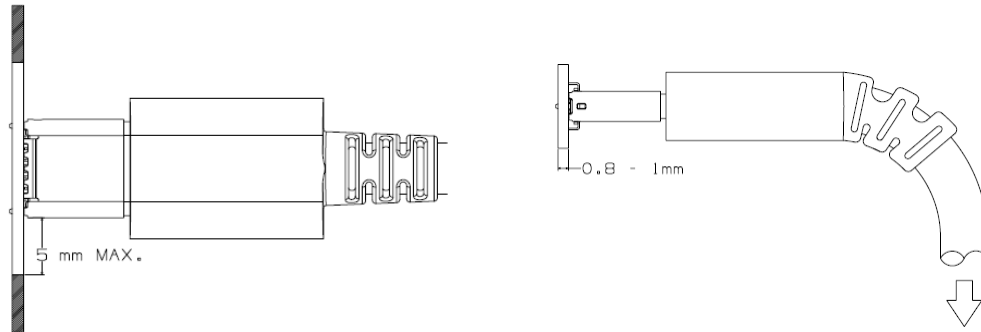

3.8.1.7 Wrenching Strength

The wrenching strength test shall be performed using virgin parts. Perpendicular forces (F_p) are applied to a plug when inserted at a distance (L) of 15 mm from the edge of the receptacle. These forces shall be applied in all four directions (i.e., left, right, up, and down). Compliant connectors shall meet the following force thresholds:

- No plug or receptacle damage shall occur when a force of 0-50 N is applied
- The plug may be damaged, but only in such a way that the receptacle does not sustain damage when a force of 50-75 N is applied.
- The plug shall be mated with a different receptacle after the forces are applied to verify no damage has occurred that causes discontinuity or shorting.

A plug should be tested with a full shell receptacle compliant with the receptacle dimensions shown in Figure 3-1.

A receptacle should be tested with a cable assembly having a plug compliant with the dimensions shown in Figure 3-3.

3.8.1.8 Restriction of Hazardous Substances

It is recommended that components be RoHS compliant.

3.8.2 Environmental Requirements

The connector interface environmental tests shall follow EIA 364-1000.01, Environmental Test Methodology for Assessing the Performance of Electrical Connectors and Sockets Used in Business Office Applications.

Since the connector defined has more than 0.127 mm wipe length, Test Group 6 in EIA 364-1000.01 is not required. The temperature life test duration and the mixed flowing gas test duration values are derived from EIA 364-1000.01 based on the field temperature per the following.

Table 3-31 Environmental Test Conditions

Temperature Life test temperature and duration	105 °C for 120 hours
Temperature Life test temperature and duration for preconditioning	105 °C for 72 hours
Mixed flowing gas test duration	7 days

The pass/fail criterion for the low level contact resistance (LLCR) is as defined in Section 3.7.7.1. The durability ratings are defined in Section 3.8.1.3.

3.8.2.1 Reference Materials (Informative)

This specification does not specify materials for connectors and cables. Connector and cable manufacturers should select appropriate materials based on performance requirements. The information below is provided for reference only.

Note: Connector and cable manufacturers should comply with contact plating requirements per the following options:

Option I

Receptacle

Contact area: (Min) 0.05 μm Au + (Min) 0.75 μm Ni-Pd on top of (Min) 2.0 μm Ni

Plug

Contact area: (Min) 0.05 μm Au + (Min) 0.75 μm Ni-Pd on top of (Min) 2.0 μm Ni

Option II

Receptacle

Contact area: (Min) 0.75 μm Au on top of (Min) 2.0 μm Ni

Plug

Contact area: (Min) 0.75 μm Au on top of (Min) 2.0 μm Ni

Other reference materials that connector and cable manufacturers select based on performance parameters listed in Table 3-32 are for reference only.

Table 3-32 Reference Materials

Component	Materials
Cable	Conductor: copper with tin or silver plating
	SDP Shield: AL foil or AL/mylar foil
	Coaxial shield: copper strand
	Braid: Tin plated copper or aluminum
	Jacket: PVC or halogen free substitute material
Cable Overmold	Thermoset or thermoplastic
Connector Shells	Stainless steel or phosphor bronze
Plug Side Latches	Stainless steel
Receptacle Mid-Plate	Stainless steel
Plug Internal EMC Spring	Stainless steel or high yield strength copper alloy
Receptacle EMC Pad	Stainless steel or phosphor bronze
Receptacle Shell	Stainless steel or phosphor bronze
Receptacle Tongue	Glass-filled nylon
Housing	Thermoplastics capable of withstanding lead-free soldering temperature

Note: Halogen-free materials should be considered for all plastics

3.9 Docking Applications (Informative)

In this specification, docking refers to plugging a device directly into a dock without using a cable assembly. The USB Type-C connector is defined to support such applications.

The connector is only part of a docking solution. A complete docking solution at the system level may also include retention or locking mechanisms, alignment mechanisms, docking plug mounting solutions, and protocols supported through the connector. This specification does not attempt to standardize system docking solutions, therefore there is no interoperability requirement for docking solutions.

The following list includes the requirements and guidelines when using the USB Type-C connector for docking:

1. The USB Type-C plug used for docking shall work with compliant USB Type-C receptacle. It shall comply with all dimensional, electrical and mechanical requirements.
2. If the plug on the dock does not include the side latches, then the dock should provide a retention or locking mechanism to secure the device to the plug. The retention latches also serve as one of the ground return paths for EMC. The docking design should ensure adequate EMC performance without the side latches if they are not present.
3. The internal EMC fingers are not required for the docking plug as long as the receptacle and plug shells have adequate electrical connection.
4. Alignment is critical for docking. Depending on system design, standard USB Type-C connectors alone may not provide adequate alignment for mating. System level alignment is highly recommended. Alignment solutions are implementation-specific.

5. Fine alignment is provided by the connector. The receptacle front face may have lead-in features for fine alignment. Figure 3-58 shows an example of a USB Type-C receptacle with a lead-in flange compared to a receptacle without the flange.

Figure 3-58 USB Type-C Cable Receptacle Flange Example

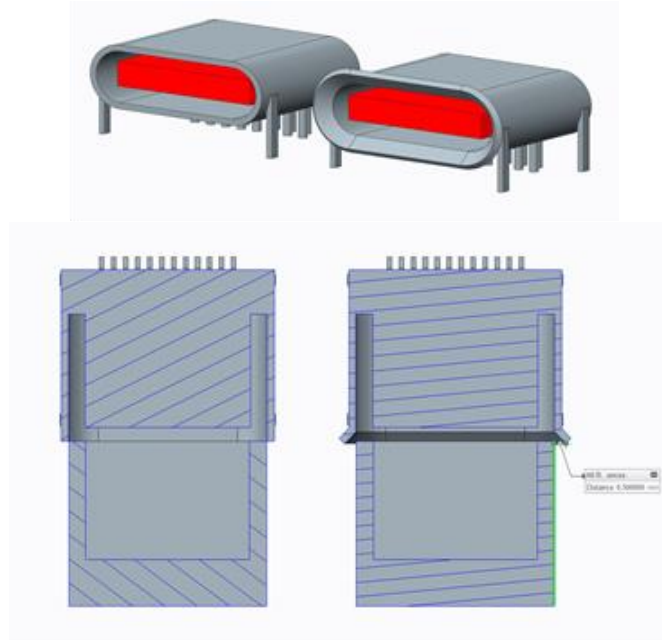

3.10 Implementation Notes and Design Guides

This section discusses a few implementation notes and design guides to help users design and use the USB Type-C connectors and cables.

3.10.1 EMC Management (Informative)

Connector and cable assembly designers, as well as system implementers should pay attention to receptacle and cable assembly shielding to ensure a low-impedance grounding path. The following are guidelines for EMC management:

- The quality of raw cables should be ensured. The intra-pair skew or the differential to common mode conversion of the SuperSpeed pairs has a significant impact on cable EMC and should be controlled within the limits of this specification.
- The cable external braid should be physically connected to the plug metal shell as close to 360° as possible to control EMC. Without appropriate shielding termination, even a perfect cable with zero intra-pair skew may not meet EMC requirements. Copper tape may be needed to shield off the braid termination area.
- The wire termination contributes to common-mode noise. The breakout distance for the wire termination should be kept as small as possible to optimize EMC and signal integrity performance. If possible, symmetry should be maintained for the two lines within a differential pair.
- Besides the mechanical function, the side latches on the plug and the mid-plate in the receptacle also play a role for EMC. This is illustrated in Figure 3-59:
 1. The side latch should have electrical connection to the receptacle mid-plate (a docking plug may not have side latches).

2. The side latches should be terminated to the paddle card GND plane inside the plug.
3. The mid-plate should be directly connected to system PCB GND plane with 3 or more solder leads/tails.

Figure 3-59 EMC Guidelines for Side Latch and Mid-plate

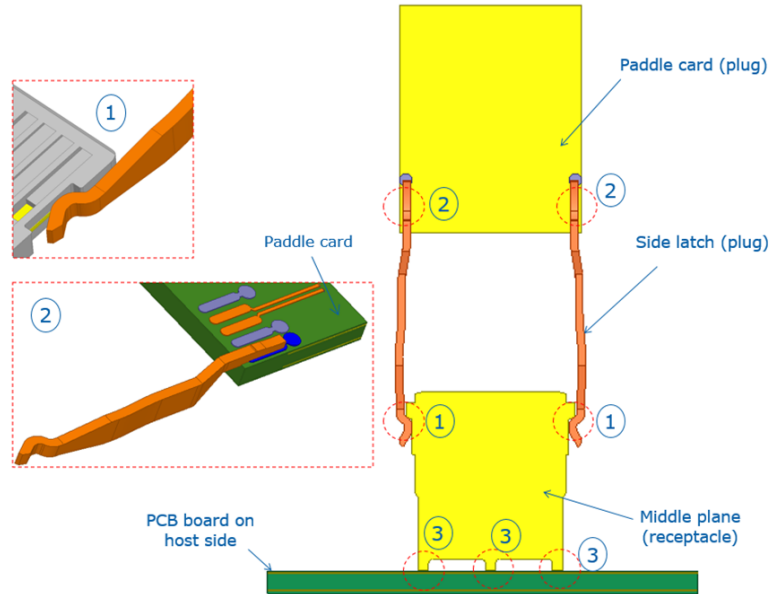

- The internal RFI finger inside the plug should have adequate connection points to the inner surface of the plug shell. Four or more connection points are recommended as illustrated in Figure 3-60.

Figure 3-60 EMC Finger Connections to Plug Shell

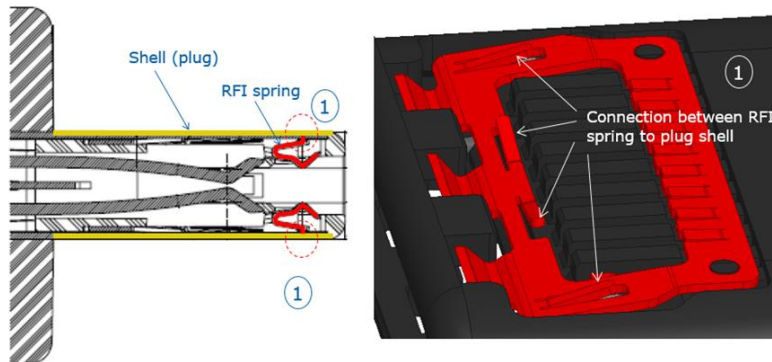

- The EMC fingers inside the plug mates with the EMC pad in the receptacle. It is important for the EMC pad to have adequate connections to the receptacle shell. As illustrated in Figure 3-61, there are multiple laser welding points between the EMC pads and the receptacle shell, top and bottom.

- The receptacle shell should have sufficient connection points to the system PCB GND plane with apertures as small as possible. Figure 3-61 illustrates an example with multiple solder tails to connect the receptacle shell to system PCB GND.

Figure 3-61 EMC Pad Connections to Receptacle Shell

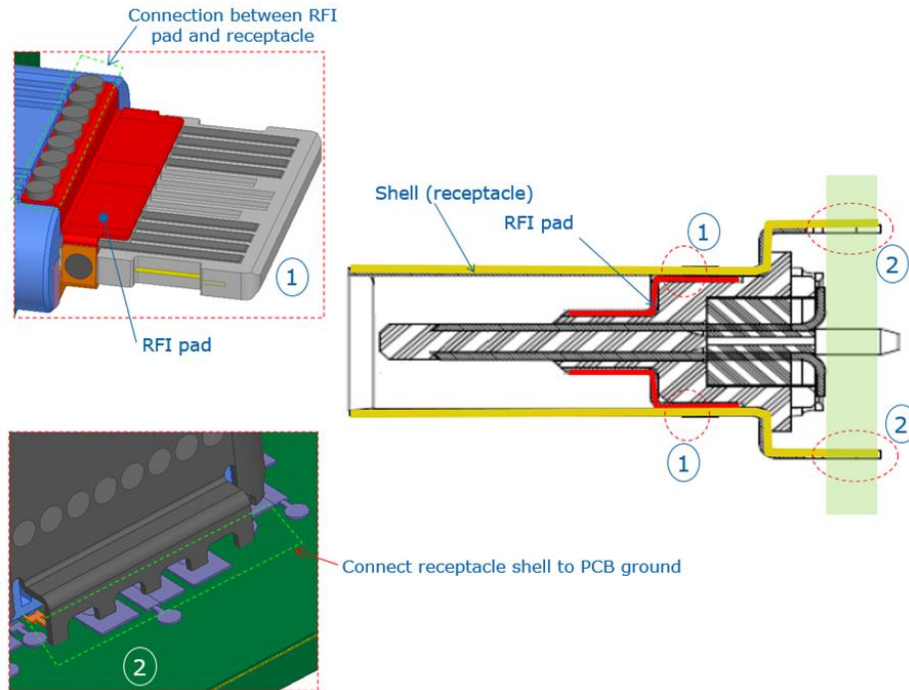

- Apertures in the receptacle and plug shells should be minimized. If apertures are unavoidable, a maximum aperture size of 1.5 mm is recommended. See Figure 3-62 for aperture illustrations. Copper tape may be applied to seal the apertures inside the cable plug.

Figure 3-62 Examples of Connector Apertures

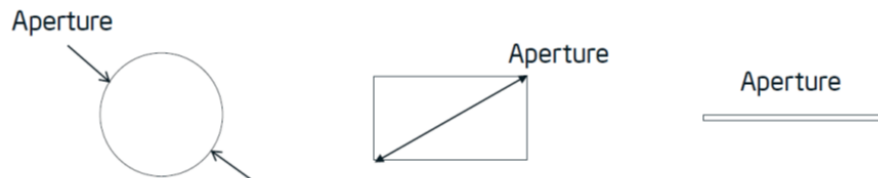

- The receptacle connectors should be connected to metal chassis or enclosures through grounding fingers, screws, or any other way to manage EMC.

3.10.2 Stacked and Side-by-Side Connector Physical Spacing (Informative)

Stacked and side-by-side USB connectors are commonly used in PC systems. Figure 3-63 illustrates the recommended spacing between connectors for stacked and side-by-side configurations.

Figure 3-63 Recommended Minimum Spacing between Connectors

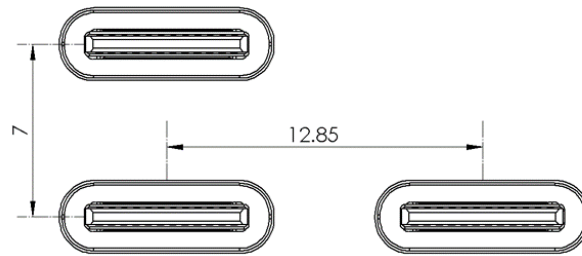

3.10.3 Cable Mating Considerations (Informative)

The receptacle mounting location, exterior product surfaces, cable overmold, and plug mating length need to be considered to ensure the USB Type-C plug is allowed to fully engage the USB Type-C receptacle. Figure 3-64 illustrates the recommended minimum plug overmold clearance to allow the cable plug to fully seat in the product receptacle.

Figure 3-64 Recommended Minimum Plug Overmold Clearance

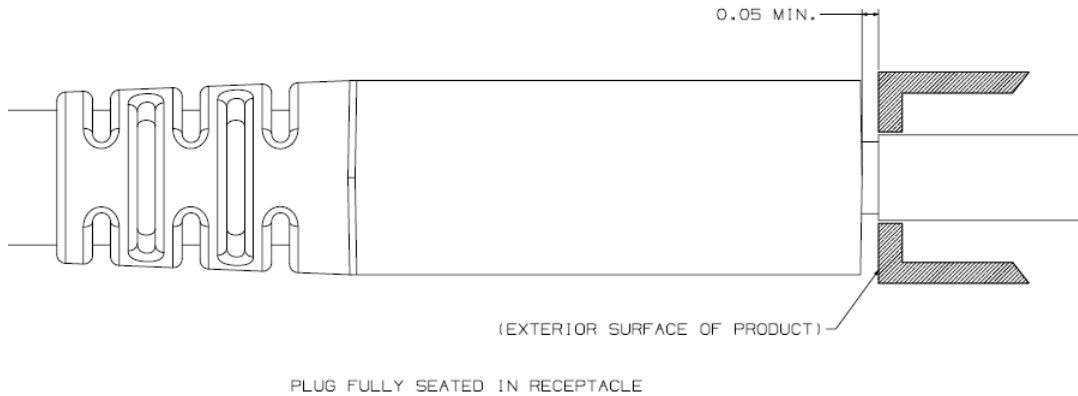
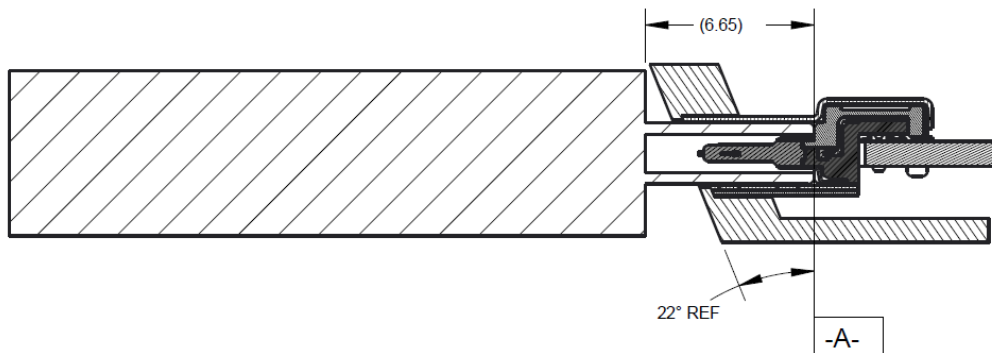

Figure 3-65 illustrates special considerations required when external walls are angled. For such applications, the USB Type-C receptacle shell may not provide as much mechanical alignment protection to the receptacle tongue as in the full shell design. Design options to allow the receptacle to pass mechanical test requirements include relief in the exterior wall surface to allow use of a full shell receptacle or use of a receptacle specifically designed for the application.

Figure 3-65 Cable Plug Overmold and an Angled Surface



4 Functional

This chapter covers the functional requirements for the signaling across the USB Type-C cables and connectors. This includes functional signal definition, discovery and configuration processes, and power delivery.

For purposes of this description, a USB port operating as a host is referred to as the Downstream Facing Port (DFP) and a USB port operating as a device is referred to as the Upstream Facing Port (UFP).

Chapter 5 defines functional extensions that are optional.

4.1 Signal Summary

Table 4-1 summarizes the list of signals used on the USB Type-C connectors.

Table 4-1 USB Type-C List of Signals

Signal Group	Signal	Description
USB 3.1	SSTXp1, SSTXn1 SSRXp1, SSRXn1 SSTXp2, SSTXn2 SSRXp2, SSRXn2	SuperSpeed USB serial data interface defines 1 differential transmit pair and 1 differential receive pair. On a USB Type-C receptacle, two sets of SuperSpeed USB signal pins are defined to enable plug flipping feature
USB 2.0	Dp1, Dn1 Dp2, Dn2	USB 2.0 serial data interface defines a differential pair. On a USB Type-C receptacle, two set of USB 2.0 signal pins are defined to enable plug flipping feature
Configuration	CC1, CC2 (receptacle) CC (plug)	CC channel in the plug used for connection detect, interface configuration and VCONN
Auxiliary signals	SBU1, SBU2	Sideband Use
Power	VBUS	USB cable bus power
	VCONN (plug)	USB plug power
	GND	USB cable return current path

4.2 Signal Pin Descriptions

4.2.1 SuperSpeed USB Pins

**SSTXp1, SSTXn1
(SSTXp2, SSTXn2)** These pins are required to implement the system's transmit path of a [USB 3.1](#) SuperSpeed interface. The transmitter differential pair in a port are routed to the receiver differential pair in the port at the opposite end of the path. The [USB 3.1 Specification](#) defines all electrical characteristics, enumeration, protocol, and management features for this interface.

Two pairs of pins are defined to enable the plug flipping feature – see Section 4.5.1.1 for further definition.

**SSRXp1, SSRXn1
(SSRXp2, SSRXn2)** These pins are required to implement the system's receive path of a [USB 3.1](#) SuperSpeed interface. The receiver differential pair in a port are routed to the transmitter differential pair in the port at the opposite end of the path. The [USB 3.1 Specification](#) defines all electrical characteristics, enumeration, protocol, and management features for this interface.

Two pairs of pins are defined to enable the plug flipping feature – see Section 4.5.1.1 for further definition.

4.2.2 USB 2.0 Pins

Dp1, Dn1 (Dp2, Dn2)

These pins are required to implement [USB 2.0](#) functionality. [USB 2.0](#) in all three modes (LS, FS, and HS) is supported. The [USB 2.0 Specification](#) defines all electrical characteristics, enumeration, and bus protocol and bus management features for this interface.

Two pairs of pins are defined to enable the plug flipping feature – see Section 4.5.1.1 for further definition.

4.2.3 Auxiliary Signal Pins

SBU1, SBU2

These pins are assigned to sideband use. Refer to Section 4.3 for the functional requirements.

4.2.4 Power and Ground Pins

VBUS

These pins are for USB cable bus power as defined by the USB specifications. This source is only present when a DFP-to-UFPP connection across the CC channel is present – see Section 4.5.1.2.1. Refer to Section 4.4.2 for the functional requirements for VBUS.

VCONN

VCONN is applied to the unused CC pin to supply power to the local plug. Refer to Section 4.4.3 for the functional requirements for VCONN.

GND

Return current path.

4.2.5 Configuration Pins

CC1, CC2, CC

These pins are used to detect connections and configure the interface across the USB Type-C cables and connectors. Refer to Section 4.5 for the functional definition. Once a connection is established, CC1 or CC2 will be reassigned for providing power over the VCONN pin of the plug – see Section 4.5.1.2.1.

4.3 Sideband Use (SBU)

The Sideband Use pins (SBU1 and SBU2) are limited to the uses as defined by this specification and additional functionality will be defined in future versions of the USB specifications. See Section 5.1 and Appendix A for use of the SBU pins in Alternate Modes and Audio Adapter Accessory Mode.

The SBU pins on a port shall either be open circuit or have a weak pull-down to ground no stronger than [zSBU Termination](#).

These pins are pre-wired in the standard USB Full-Featured Type-C cable as individual single-ended wires (SBU_A and SBU_B). Note that SBU1 and SBU2 are cross-connected in the cable.

4.4 Power and Ground

4.4.1 IR Drop

The maximum allowable cable IR drop for ground shall be 250 mV and for VBUS shall be 500 mV through the cable to the cable's maximum rated VBUS current capacity. When VCONN is being sourced, the IR drop for the ground shall still be met considering any additional VCONN return current.

Figure 4-1 illustrates what parameters contribute to the IR drop and where it shall be measured. The IR drop includes the contact resistance of the mated plug and receptacles at each end.

Figure 4-1 Cable IR Drop

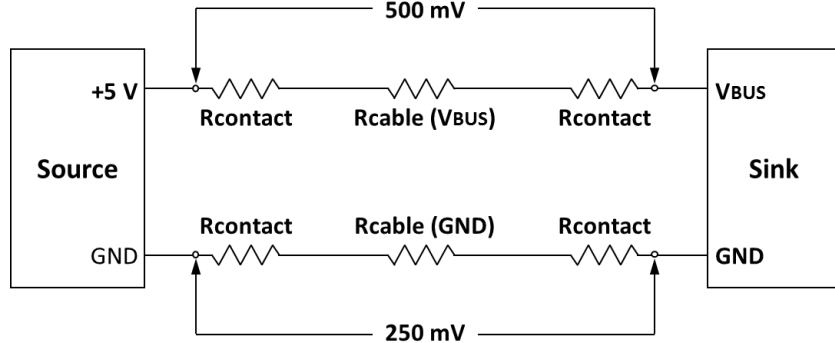
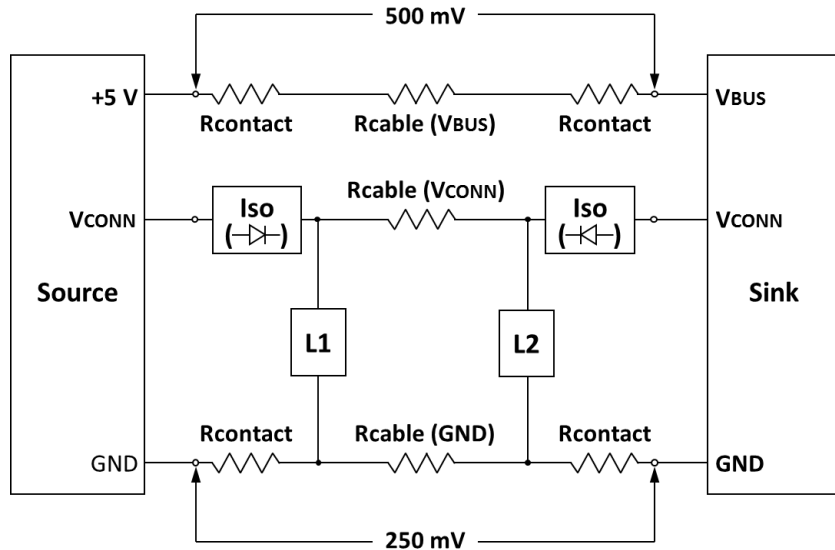

Figure 4-2 illustrates what parameters contribute to the IR drop for a powered cable and where it shall be measured. Note that the powered cable includes isolation elements (Iso) and loads (L1 and L2) for the functions in the powered cable such as [USB PD](#) controllers. The IR drop shall remain below 250 mV in all cases.

Figure 4-2 Cable IR Drop for powered cables



4.4.2 VBUS

The allowable default range for VBUS as measured at the DFP receptacle shall be as defined by the [USB 2.0 Specification](#) and [USB 3.1 Specification](#). Note that due to higher currents allowed, legacy devices may experience a higher voltage (up to 5.5V maximum) at light loads.

The DFP's USB Type-C receptacle VBUS pin shall remain unpowered until a UFP is attached. The VBUS pin shall return to the unpowered state when the UFP is detached. See Table 4-15 for VBUS timing values. Legacy hosts/chargers that by default source VBUS when connected

using any legacy USB connector (Standard-A, Micro-B, etc.) to USB Type-C cable or adapter are exempted from these two requirements.

4.4.3 VCONN

VCONN is provided by the DFP to power cables with electronics in the plug. VCONN is provided over the CC pin that is determined not to be connected to the CC wire of the cable.

Initially, VCONN shall be sourced on all DFP USB Type-C receptacles that utilize the SSTX and SSRX pins during specific connection states as described in Section 4.5.2.2. VCONN may be sourced on DFP USB Type-C receptacles that do not utilize the SSTX and SSRX pins as described in Section 4.5.2.2. [USB PD](#) VCONN_Swap command also provides the DFP a means to request that the attached UFP source VCONN.

Table 4-2 provides the voltage and power requirements that shall be met for VCONN. See Section 4.9 for more details about Electronically Marked Cables. See Section 4.10 for a wider VCONN voltage operating range for VCONN-powered accessories. See Section 5.1 regarding optional support for an increased VCONN power range in Alternate Modes.

Table 4-2 VCONN Source Characteristics

	Minimum	Maximum	Notes
Voltage	4.75 V	5.5 V	Ports that support VCONN-powered accessories are allowed to supply at a lower minimum of 2.7 V when operating in the Powered.Accessory state.
Power	1.0 W		Source may latch-off VCONN if excessive power is drawn beyond the specified inrush and mode wattage.
Bulk Capacitance	10 μ F	220 μ F	The VCONN source shall disconnect the bulk capacitance from the receptacle when VCONN is powered off.

To aid in reducing the power associated with supplying VCONN, a DFP is allowed to either not source VCONN or turn off Vconn under any of the following conditions:

- [Ra](#) is not detected on the CC pin that is not connected to the CC wire
- After completing the [USB PD](#) Discover Identity process and determining that VCONN is not needed
- If there is no response to [USB PD](#) Discover Identity messages

Table 4-3 provides the requirements that shall be met for cables that consume VCONN power.

Table 4-3 VCONN Sink Characteristics

	Minimum	Maximum	Notes
Inrush Capacitance		10 μ F	A cable shall not present more than the equivalent inrush capacitance to the VCONN source. The active cable is responsible for discharging its capacitance.
Power for Electronically Marked Cables		70 mW	See Section 4.9.
Power for Active Cables		1.0 W	See Section 5.2.
tVCONNDischarge		250 ms	The time from the point that the cable is detached until vVCONNDischarge shall be met.
vVCONNDischarge		150 mV	The VCONN voltage following cable detach and self-discharge.

The cable may remove or weaken [Ra](#) when VCONN is above 1.0 V as long as the other requirements are met. See Section 4.5.1.2.1.

4.5 Configuration Channel (CC)

4.5.1 Architectural Overview

For the USB Type-C solution, two pins on the connector, CC1 and CC2, are used to establish and manage the DFP-to-UFP connection. Note that in this section, “direct connect” is used to refer to a device connected directly to a host (e.g., a thumb drive). When the device is connected through a hub, the connection between a UFP on the hub and the host port and the connection between the device port and a DFP on the hub, are treated as separate connections. Functionally, the configuration channel is used to serve the following purposes.

- Detect attach of USB ports, e.g. a DFP to a UFP
- Resolve cable orientation and twist connections to establish USB data bus routing
- Establish DFP and UFP roles between two attached ports
- Discover and configure VBUS: USB Type-C Current modes or [USB Power Delivery](#)
- Configure VCONN
- Discover and configure optional Alternate and Accessory modes

4.5.1.1 USB Data Bus Interface and USB Type-C Plug Flip-ability

Since the USB Type-C plug can be inserted in either right-side-up or upside-down position, the hosts and devices that support USB data bus functionality must operate on the signal pins that are actually connected end-to-end. In the case of USB 2.0, this is done by shorting together the two D+ signal pins and the two D- signal pins in the DFP and UFP receptacles. In the case of USB SuperSpeed signals, it requires the functional equivalent of a switch in both the DFP and UFP to appropriately route the SuperSpeed TX and RX signal pairs to the connected path through the cable.

Figure 4-3 illustrates the logical data bus model for a USB Type-C-based DFP connected to a USB Type-C-based UFP. The USB cable that sits between a DFP and UFP can be in one of four possible connected states when viewed by the DFP:

- Un-flipped straight through – Position ① ↔ Position ①
- Un-flipped twisted through – Position ① ↔ Position ②
- Flipped straight through – Position ② ↔ Position ②
- Flipped twisted through – Position ② ↔ Position ①

To establish the proper routing of the active USB data bus from DFP to UFP, the standard USB Type-C cable is wired such that a single CC wire is position aligned with the first USB SuperSpeed signal pairs (SSTXp1/SSTXn1 and SSRXp1/SSRXn1) – in this way, the CC wire and USB SuperSpeed data bus wires that are used for signaling within the cable track with regard to the orientation and twist of the cable. By being able to detect which of the CC pins (CC1 or CC2) at the receptacle is terminated by the UFP, the DFP is able to determine which SuperSpeed USB signals are to be used for the connection and the DFP can use this to control the functional switch for routing the SuperSpeed USB signal pairs. Similarly in the UFP, detecting which of the CC pins at the receptacle is terminated by the DFP allows the UFP to control the functional switch that routes its SuperSpeed USB signal pairs.

Figure 4-3 Logical Model for Data Bus Routing across USB Type-C-based Ports

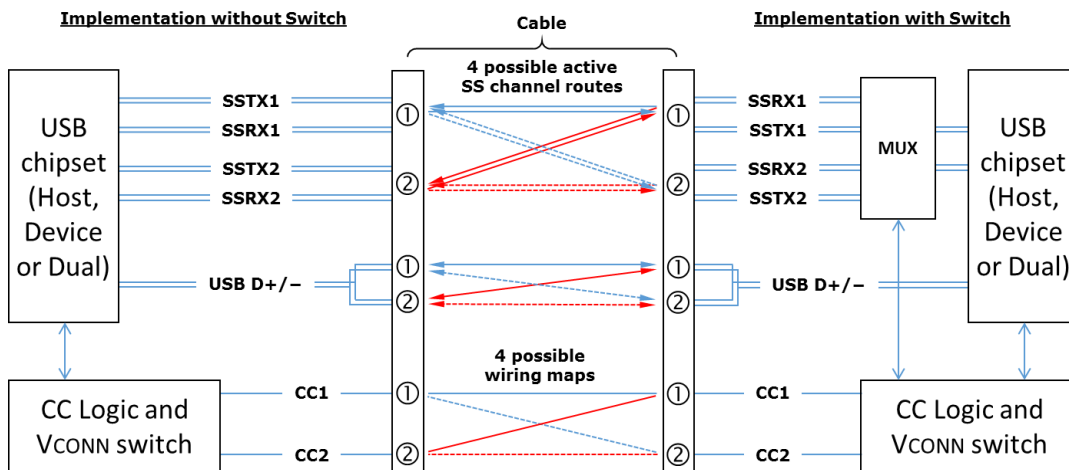

While Figure 4-3 illustrates the functional model as a DFP connected to a UFP, this model equally applies to a USB hub's DFPs as well.

Figure 4-4 illustrates the logical data bus model for a USB Type-C-based UFP (implemented with a USB Type-C plug either physically incorporated into the device or permanently attached as a captive cable) connected directly to a USB Type-C-based DFP. For the UFP, the location of the USB SuperSpeed data bus, [USB 2.0](#) data bus, CC and VCONN pins are fixed by design. Given that the UFP pin locations are fixed, only two possible connected states exist when viewed by the DFP.

Figure 4-4 Logical Model for USB Type-C-based Ports for the Direct Connect Device

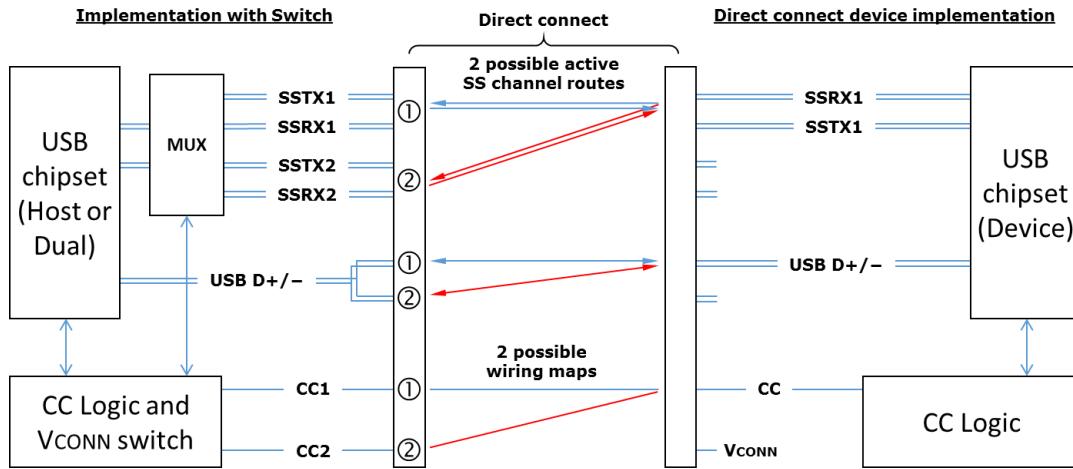

The functional requirements for implementing SuperSpeed USB data bus routing for the USB Type-C receptacle are not included in the scope of this specification. There are multiple host, device and hub architectures that can be used to accomplish this which could include either discrete or integrated switching, and could include merging this functionality with other USB 3.1 design elements, e.g. a bus repeater.

4.5.1.2 Connecting DFPs and UFPs

Given that the USB Type-C receptacle and plug no longer differentiate host and device roles based on connector shape, e.g., as was the case with USB Type-A and Type-B connectors, any two ports that have USB Type-C receptacles can be connected together with a standard USB Type-C cable. Table 4-4 summarizes the expected results when interconnecting DFP, UFP and DRP ports.

Table 4-4 USB Type-C-based Port Interoperability

	DFP	UFP	DRP
DFP	Non-functional	Functional	Functional
UFP	Functional	Non-functional	Functional
DRP	Functional	Functional	Functional*

* Resolution of roles may be automatic or manually driven

In the cases where no function results, neither port shall be harmed by this connection. The user has to independently realize the invalid combination and take appropriate action to resolve. While these two invalid combinations mimic traditional USB where DFP-to-DFP and UFP-to-UFP connections are not intended to work, the non-keyed USB Type-C solution does not prevent the user from attempting such interconnects. VBUS and VCONN shall not be applied by a DFP in these cases.

The typical flow for the configuration of the interface in the general USB case of a DFP to a UFP is as follows:

1. Detect a valid connection between the ports (including determining cable orientation and DFP/UFP relationship)
2. Optionally discover the cable's capabilities

3. Optionally establish alternatives to traditional USB power (See Section 4.6.2)
 - a. [USB PD](#) communication over CC for advanced power delivery negotiation
 - b. USB Type-C Current modes
 - c. USB BC 1.2
4. USB Device Enumeration

For cases of DRPs connecting to either DFP, UFP or another DRP, the process is essentially the same except that during the detecting a valid connection step, the DRP alternates between operating as a DFP for detecting an attached UFP and presenting as a UFP to be detected by an attached DFP. Ultimately this results in a DFP-to-UFP connection.

4.5.1.2.1 Detecting a Valid DFP-to-UFP Connection

The general concept for setting up a valid connection between a DFP and UFP is based on being able to detect terminations residing in the product being attached.

To aid in defining the functional behavior of CC, a pull-up ([Rp](#)) and pull-down ([Rd](#)) termination model is used – actual implementation in hosts and devices may vary, for example, the pull-up termination could be replaced by a current source. Figure 4-5 and Figure 4-6 illustrates two models, the first based on a pull-up resistor in the DFP and the second replacing this with a current source.

Figure 4-5 Pull-Up/Pull-Down CC Model

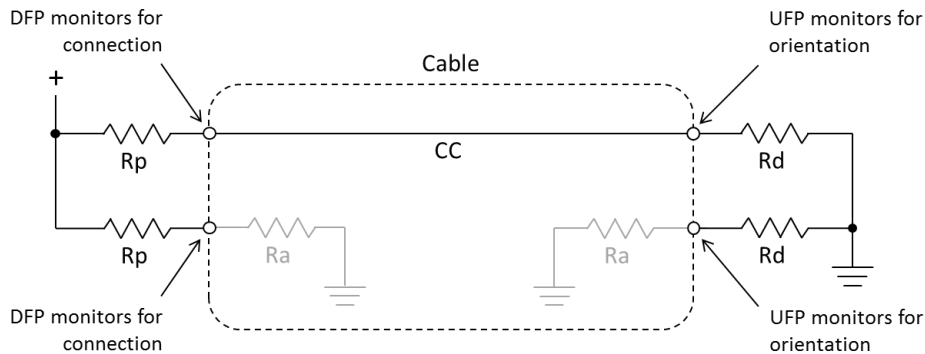
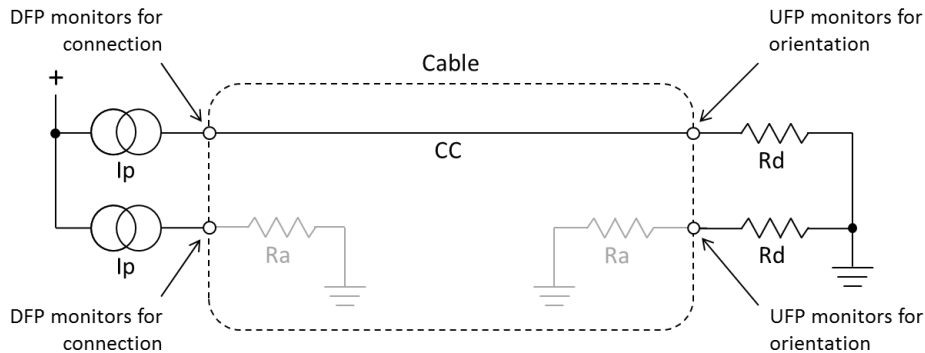

Figure 4-6 Current Source/Pull-Down CC Model



Initially, a DFP exposes [Rp](#) terminations on its CC pins and a UFP exposes [Rd](#) terminations on its CC pins, the DFP-to-UFP combination of this circuit configuration represents a valid

connection. To detect this, the DFP monitors both CC pins for a voltage lower than its unterminated voltage – the choice of [Rp](#) is a function of the pull-up termination voltage and the DFP’s detection circuit. This indicates that either a UFP, a powered cable, or a UFP connected via a powered cable has been attached.

Prior to application of VCONN, a powered cable exposes [Ra](#) on its VCONN pin. [Ra](#) represents the load on VCONN plus any resistive elements to ground. In some cable plugs it might be a pure resistance and in others it may be simply the load.

The DFP has to be able to differentiate between the presence of [Rd](#) and [Ra](#) to know whether there is a UFP attached and where to apply VCONN. The DFP is not required to source VCONN unless [Ra](#) is detected.

Two special termination combinations on the CC pins as seen by a DFP are defined for directly attached Accessory Modes: [Ra/Ra](#) for Audio Adapter Accessory Mode (Appendix A) and [Rd/Rd](#) for Debug Accessory Mode (Appendix B).

The DFP uses de-bounce timers to reliably detect states on the CC pins to de-bounce the connection ([tCCDebounce](#)), and hide [USB PD](#) BMC communications ([tPDDebounce](#)).

Table 4-5 summarizes the port state from the DFP’s perspective.

Table 4-5 DFP Perspective

CC1	CC2	State	Position
Open	Open	Nothing attached	N/A
Rd	Open	UFP attached	①
Open	Rd		②
Open	Ra	Powered cable/No UFP attached	①
Ra	Open		②
Rd	Ra	Powered cable/UFP attached	①
Ra	Rd		②
Rd	Rd	Debug Accessory Mode attached (Appendix B)	N/A
Ra	Ra	Audio Adapter Accessory Mode attached (Appendix A)	N/A

When the UFP senses VBUS, the UFP monitors both CC pins for a voltage greater than its local ground. The CC pin that is at a higher voltage (i.e. pulled up by [Rp](#) in the DFP) indicates the orientation of the plug.

Table 4-6 summarizes the typical behaviors for simple DFPs and UFPs for each state in Table 4-5.

Table 4-6 DFP and UFP Behaviors by State

State	DFP Behavior	UFP Behavior
Nothing attached	<ul style="list-style-type: none"> • Sense CC pins for attach • Do not apply VBUS or VCONN 	<ul style="list-style-type: none"> • Sense VBUS for attach
UFP attached	<ul style="list-style-type: none"> • Sense CC for orientation • Sense CC for detach • Apply VBUS and VCONN 	<ul style="list-style-type: none"> • Sense CC pins for orientation • Sense loss of VBUS for detach
Powered cable/No UFP attached	<ul style="list-style-type: none"> • Sense CC pins for attach • Do not apply VBUS or VCONN 	<ul style="list-style-type: none"> • Sense VBUS for attach
Powered cable/UFP attached	<ul style="list-style-type: none"> • Sense CC for orientation • Sense CC for detach • Apply VBUS and VCONN 	<ul style="list-style-type: none"> • Sense CC pins for orientation • Sense loss of VBUS for detach
Debug Accessory Mode attached	<ul style="list-style-type: none"> • Sense CC pins for detach • Reconfigure for debug 	<ul style="list-style-type: none"> • N/A
Audio Adapter Accessory Mode attached	<ul style="list-style-type: none"> • Sense CC pins for detach • Reconfigure for analog audio 	<ul style="list-style-type: none"> • N/A

Figure 4-3 shows how the inserted plug orientation is detected at the DFP's receptacle by noting on which of the two CC pins in the receptacle an [Rd](#) termination is sensed. Now that the DFP has recognized that a UFP is attached and the plug orientation is determined, it configures the SuperSpeed USB data bus routing to the receptacle.

The DFP then turns on VBUS. For the CC pin that does not connect DFP-to-UFP through the cable, the DFP supplies VCONN and may remove the termination. With the UFP now powered, it configures the USB data path. This completes the DFP-to-UFP connection.

The DFP monitors the CC wire for the loss of pull-down termination to detect detach. If the UFP is removed, the DFP port removes any voltage applied to VBUS and VCONN, resets its interface configuration and resumes looking for a new UFP attach.

Once a valid DFP-to-UFP connection is established, alternatives to traditional USB power (VBUS as defined by either [USB 2.0](#) or [USB 3.1](#) specifications) may be available depending on the capabilities of the host and device. These include USB Type-C Current, USB Power Delivery, and [USB Battery Charging 1.2](#).

In the case where [USB PD](#) PR_Swap is used to swap the source and sink of VBUS, the source of VCONN remains unchanged during and after the VBUS power swap. The new source monitors the CC wire and the new sink monitors VBUS to detect detach. When a detach event is detected, any voltages applied to VBUS and VCONN are removed, each port resets its interface configuration and resumes looking for an attach event.

In the case where [USB PD](#) DR_Swap is used to swap the DFP and UFP, the new UFP maintains sourcing VCONN during and after the data role swap.

In the case where [USB PD](#) VCONN_Swap is used to swap the VCONN source, the VBUS source/sink and DFP/UFP roles are maintained during and after the VCONN swap.

The last step in the normal USB Type-C connect process is for the USB device to be attached and enumerated per standard [USB 2.0](#) and [USB 3.1](#) processes.

4.5.1.3 Configuration Channel Functional Models

The functional models for the configuration channel behavior based on the CC1 and CC2 pins are described in this section for each port type: DFP, UFP and DRP.

The figures in the following sections illustrate the CC1 and CC2 routing after the CC detection process is complete. In these figures, VBUS and VCONN may or may not actually be available.

4.5.1.3.1 DFP Configuration Channel Functional Model

Figure 4-7 illustrates the functional model for CC1 and CC2 for a DFP prior to attach. This illustration includes consideration for the [USB PD](#) Provider.

Figure 4-7 DFP Functional Model for CC1 and CC2

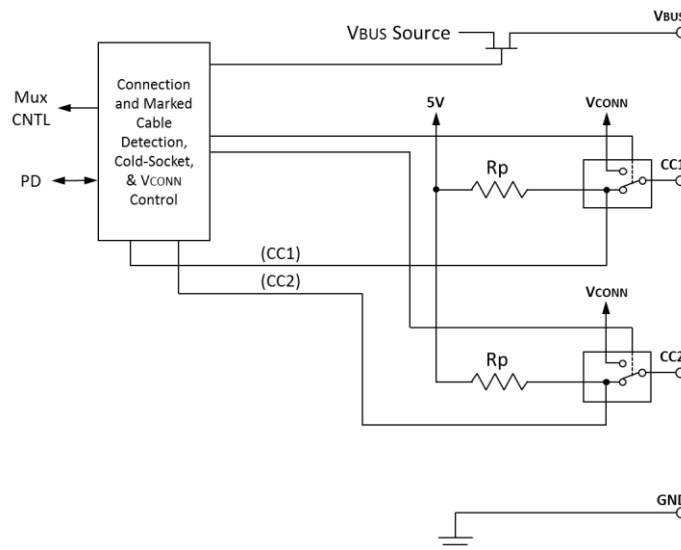

Referring to Figure 4-7, a port that behaves as a DFP has the following functional characteristics:

1. The DFP uses a FET to enable/disable power delivery across VBUS and initially the DFP has VBUS disabled.
2. The DFP supplies pull-up resistors (R_p) on CC1 and CC2 and monitors both CC pins to detect a UFP – the presence of an R_d pull-down resistor on either pin indicates that a UFP is being attached. The value of R_p indicates the initial USB Type-C Current level supported by the host.
3. The DFP uses the CC pin pull-down characteristic to detect and establish the correct routing for the USB SuperSpeed data path and determine which CC pin is intended for supplying VCONN.
4. Once a UFP is detected, the DFP enables VBUS and VCONN.
5. The DFP can dynamically adjust the value of R_p to indicate a change in available USB Type-C Current to a UFP.
6. The DFP monitors the continued presence of R_d to detect UFP detach. When a detach event is detected, the DFP removes VBUS and VCONN, and returns to step 2.

7. If the DFP supports advanced functions (USB Power Delivery and/or Alternate Modes), [USB PD](#) communication is required.

Figure 4-8 illustrates the functional model for CC1 and CC2 for a DFP that is a [USB PD](#) Provider/Consumer (e.g., supports [USB PD](#) PR_Swap) prior to attach.

Figure 4-8 DFP Functional Model Supporting USB PD Provider/Consumer

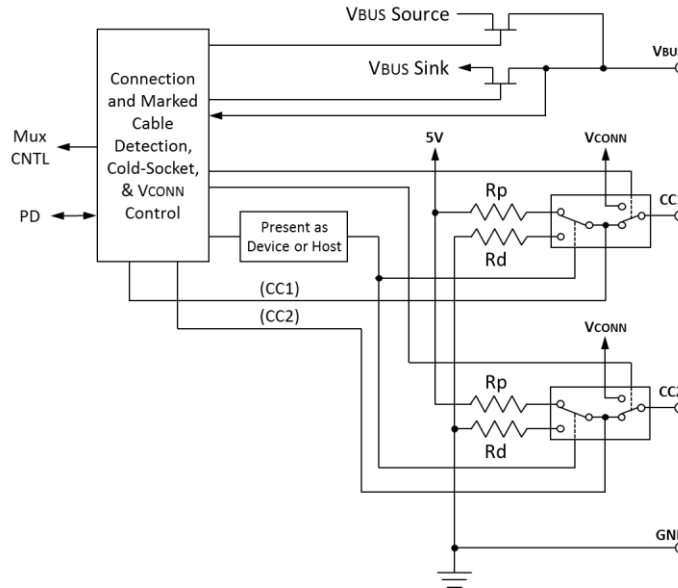

4.5.1.3.2 UFP Configuration Channel Functional Model

Figure 4-9 illustrates the functional model for CC1 and CC2 for a UFP. This illustration includes consideration for both USB Type-C Current and [USB PD](#) Consumer.

Figure 4-9 UFP Functional Model for CC1 and CC2

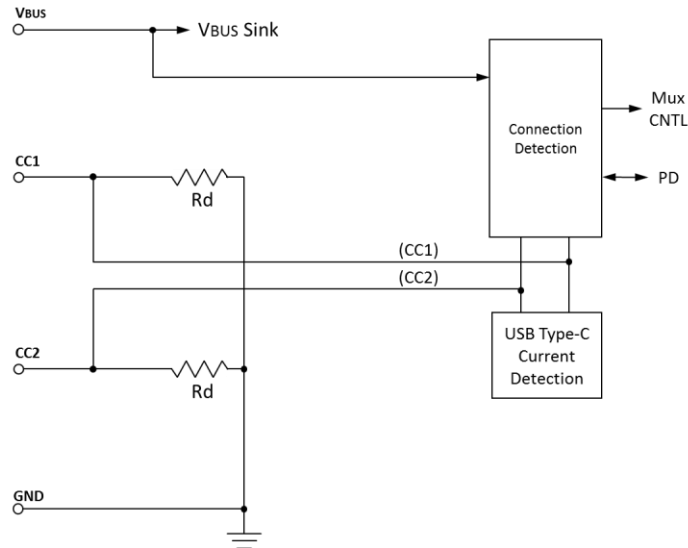

Referring to Figure 4-9, a port that behaves as a UFP has the following functional characteristics:

1. The UFP terminates both CC1 and CC2 to GND using pull-down resistors.
2. The UFP determines that a DFP is attached by the presence of power on VBUS.
3. The UFP uses the CC pin pull-up characteristic to detect and establish the correct routing for the USB SuperSpeed data path.
4. The UFP can optionally monitor CC to detect an available higher USB Type-C Current from the DFP. The UFP shall manage its load to stay within the detected DFP current limit.
5. If the UFP supports advanced functions (USB Power Delivery and/or Alternate Modes), [USB PD](#) communication is required.

Figure 4-10 illustrates the functional model for CC1 and CC2 for a UFP that is a [USB PD](#) Consumer/Provider (e.g., supports [USB PD](#) PR_Swap) and supports [USB PD](#) VCONN_Swap prior to attach.

Figure 4-10 UFP Functional Model Supporting USB PD Consumer/Provider and VCONN_Swap

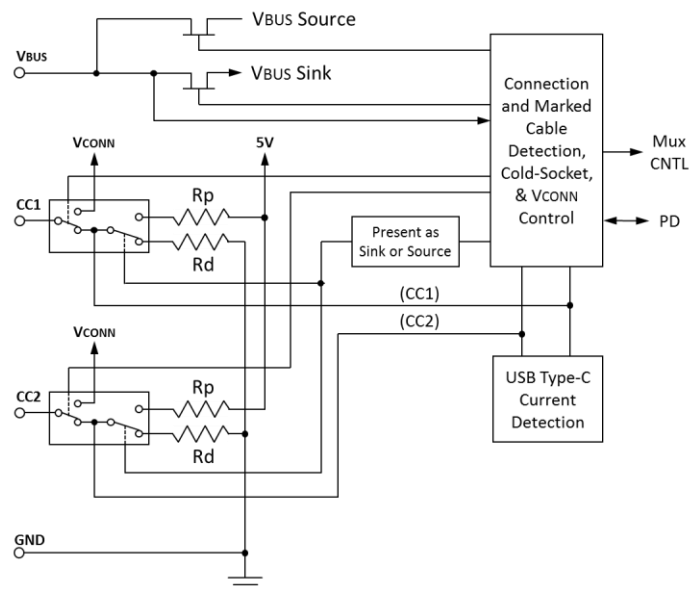

4.5.1.3.3 DRP Configuration Channel Functional Model

Figure 4-11 illustrates the functional model for CC1 and CC2 for a DRP presenting as a DFP prior to attach. This illustration includes consideration for both the USB Type-C Current and the [USB PD](#) features.

Figure 4-11 DRP Functional Model for CC1 and CC2

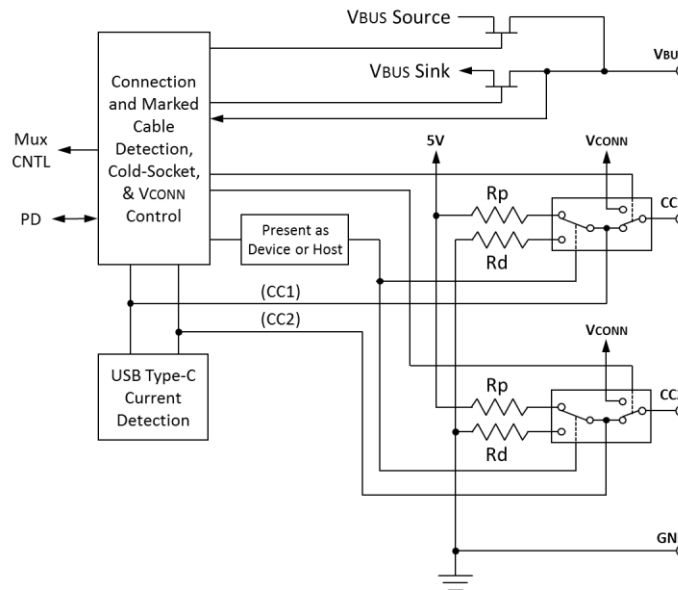

Referring to Figure 4-11, a port that can alternate between DFP and UFP behaviors has the following functional characteristics:

1. The DRP uses a FET to enable/disable power delivery across VBUS and initially when in DFP mode has VBUS disabled.
2. The DRP uses switches for presenting as a DFP or UFP.
3. The DRP has logic used during initial attach to toggle between DFP and UFP operation:
 - a. Until a specific stable state is established, the DRP alternates between exposing itself as a DFP and UFP. The timing of this process is dictated by a period (t_{DRP}), percentage of time that a DRP exposes [Rp \(dcDFP.DRP\)](#) and role transition time ($t_{DRPTransition}$).
 - b. When the DRP is presenting as a DFP, it follows DFP operation to detect an attached UFP – if a UFP is detected, it applies VBUS, VCONN, and continues to operate as a DFP for a minimum of [tDRPHold](#) (e.g., cease alternating).
 - c. When the DRP is presenting as a UFP, it monitors VBUS to detect that it is attached to a DFP – if a DFP is detected, it continues to operate as a UFP (cease alternating).
4. If the DRP supports advanced functions (USB Power Delivery and/or Alternate Modes), [USB PD](#) communication is required.
 - a. If a DRP supports [USB PD](#), initially the [USB PD](#) role follows the port role, i.e., when operating as a DFP, the [USB PD](#) operates as a Provider/Consumer and when operating as a UFP, the [USB PD](#) operates as a Consumer/Provider.

4.5.1.4 USB PD-based Power Role, Data Role and VCONN Swapping

Table 4-7 summarizes the behaviors of a port in response to the three [USB PD](#) swap commands.

Table 4-7 USB PD Swapping Port Behavior Summary

	Host/Device Data Roles	Rp/Rd	VBUS Source/Sink	VCONN Source
PR_Swap	Unchanged	Swapped	Swapped	Unchanged
DR_Swap	Swapped	Unchanged	Unchanged	Unchanged
VCONN_Swap	Unchanged	Unchanged	Unchanged	Swapped*

* Swapping of VCONN source port

4.5.2 CC Functional and Behavioral Requirements

This section provides the functional and behavioral requirements for implementing CC. The first sub-section provides connection state diagrams that are the basis for the remaining sub-sections.

4.5.2.1 Connection State Diagrams

This section provides reference connection state diagrams for CC-based behaviors. Refer to Section 4.5.2.2 for the specific state transition requirements related to each state shown in the diagrams.

Figure 4-12 illustrates a connection state diagram for a DFP.

Figure 4-12 Connection State Diagram: DFP

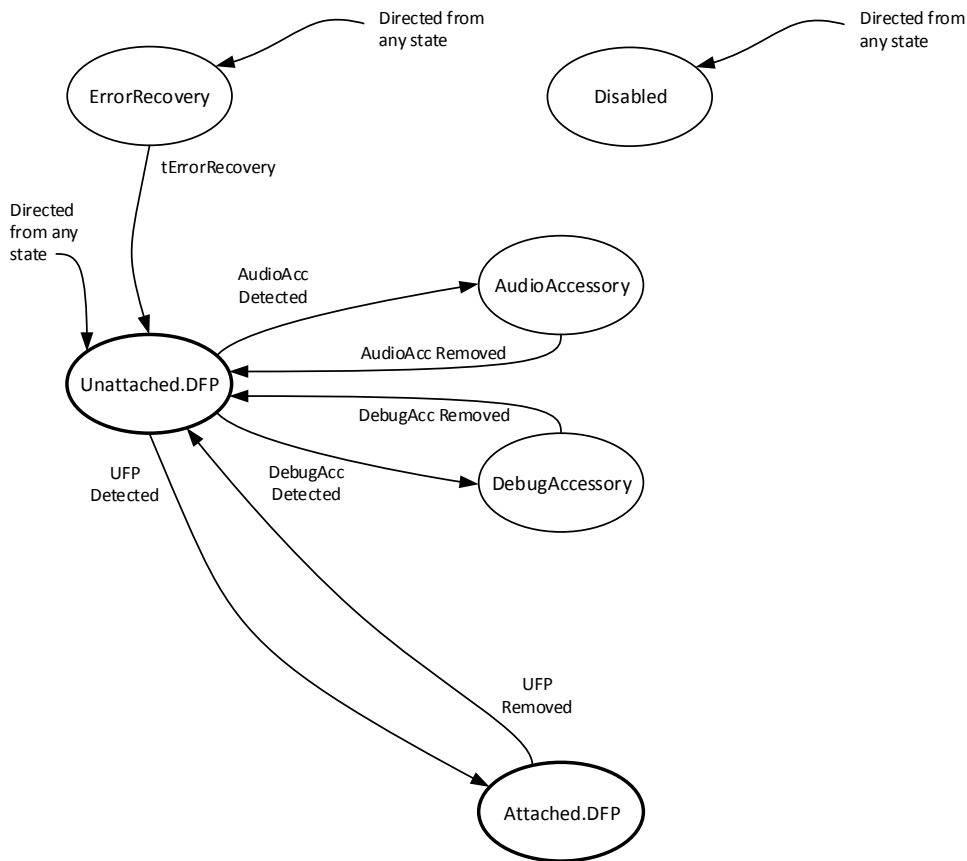

Figure 4-13 illustrates a connection state diagram for a simple UFP.

Figure 4-13 Connection State Diagram: UFP

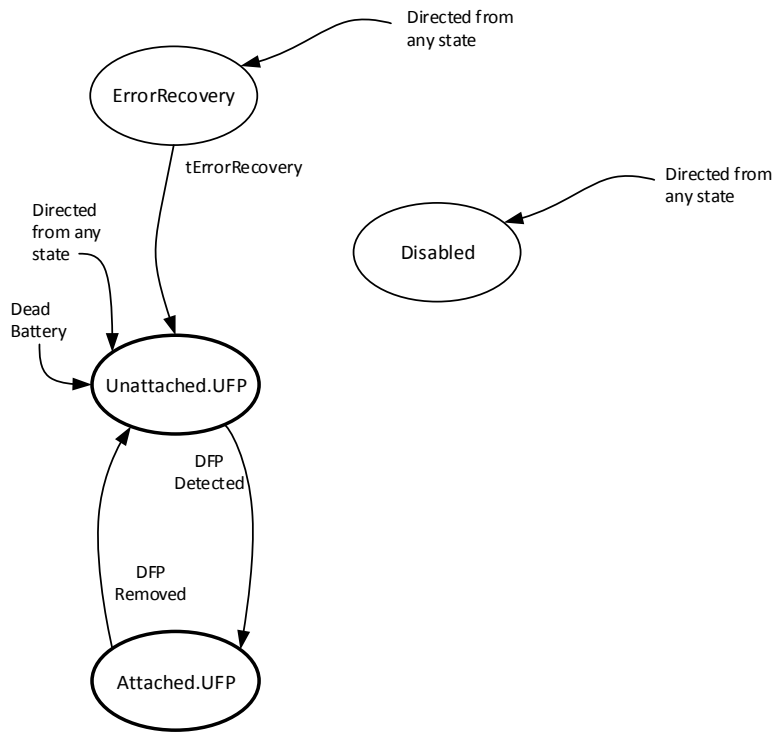

Figure 4-14 illustrates a connection state diagram for a UFP that supports Accessory Modes.

Figure 4-14 Connection State Diagram: UFP with Accessory Support

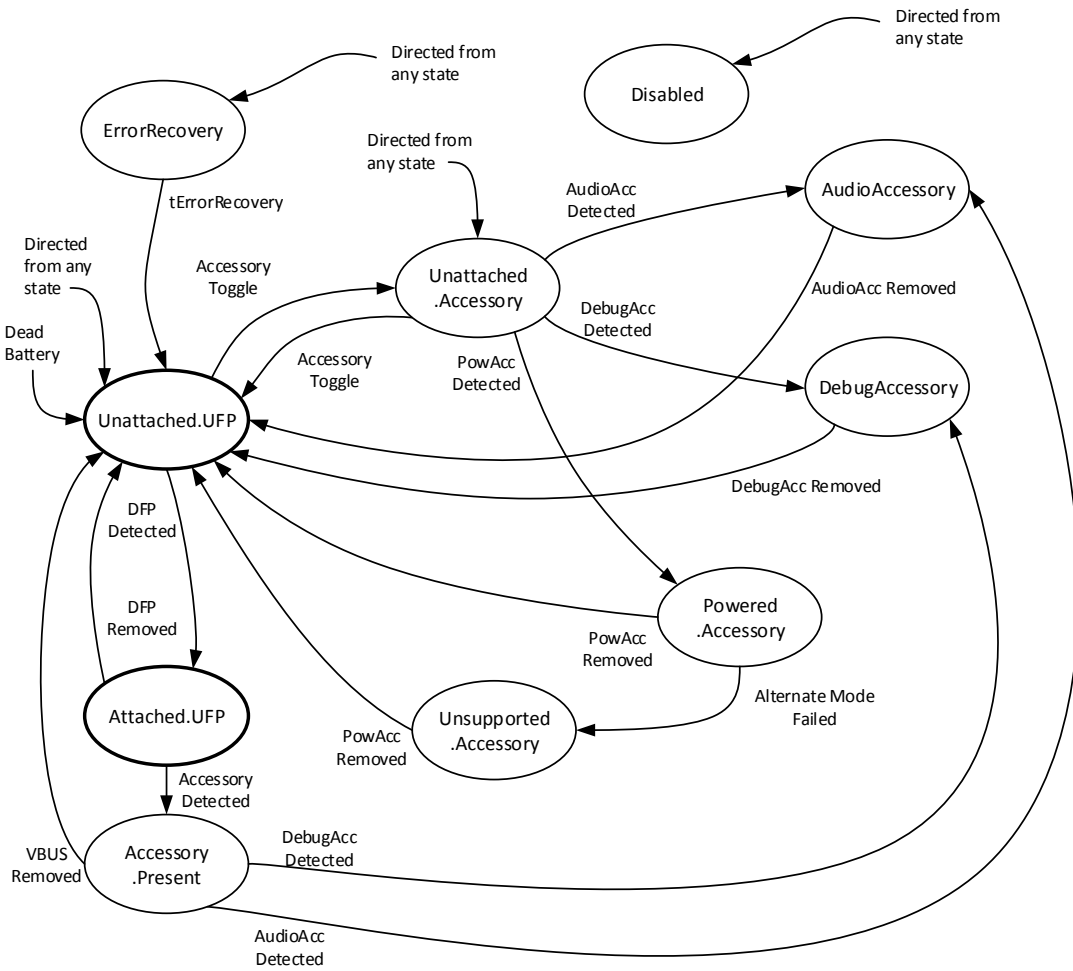

Figure 4-15 illustrates a connection state diagram for a simple DRP.

Figure 4-15 Connection State Diagram: DRP

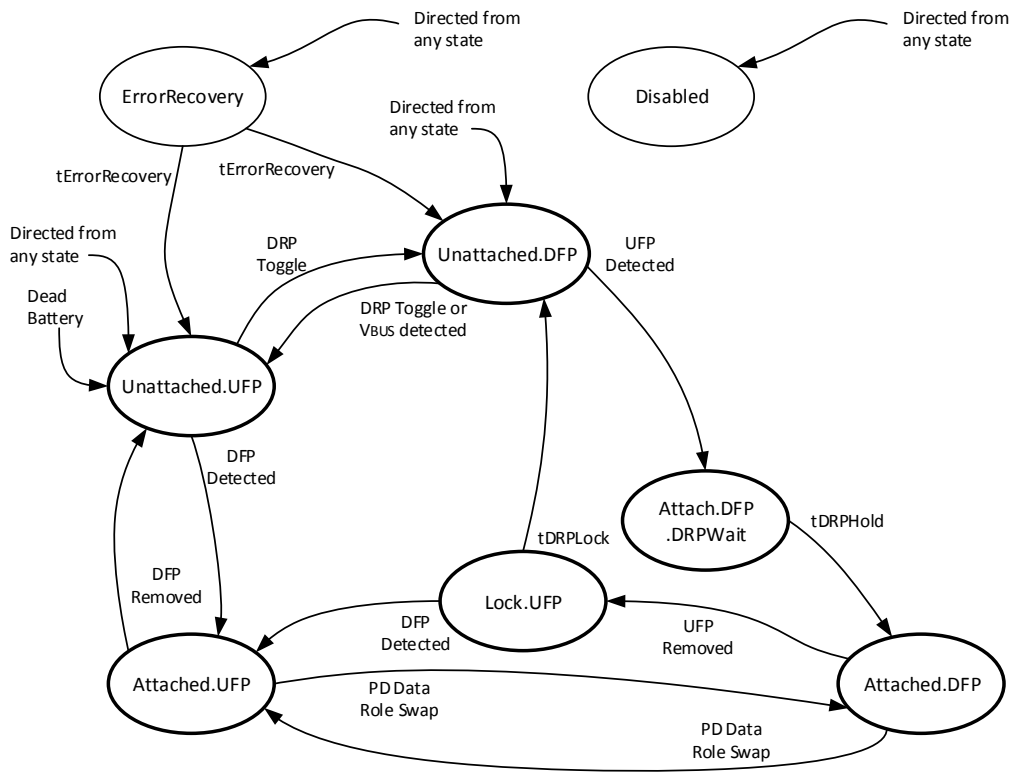
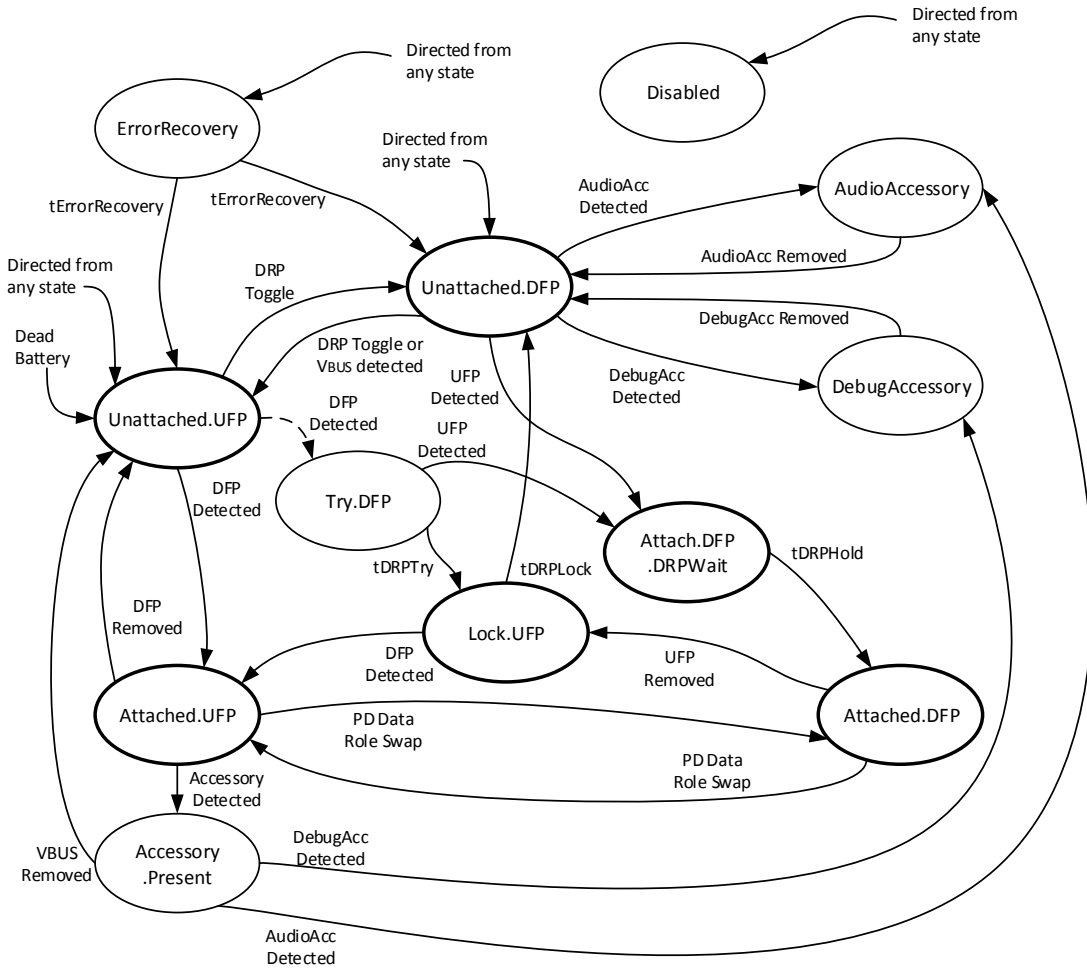

Figure 4-16 illustrates a connection state diagram for a DRP that supports all possible states including Accessory Modes and [Try.DFP](#).

Figure 4-16 Connection State Diagram: DRP with Accessory and Try.DFP Support



4.5.2.2 Connection State Machine Requirements

4.5.2.2.1 Disabled State

This state appears in Figure 4-12, Figure 4-13, Figure 4-14, Figure 4-15 and Figure 4-16.

The Disabled state is where the port prevents connection from occurring by removing all terminations from the CC pins.

The port should transition to the Disabled state from any other state when directed.

A port may choose not to support the Disabled state. If the Disabled state is not supported, the port shall be directed to either the [Unattached.UFP](#) or [Unattached.DFP](#) states after power-on.

4.5.2.2.1.1 Disabled State Requirements

The source port ([Rp](#)) shall not drive VBUS or VCONN.

The sink port ([Rd](#)) shall present a high-impedance to ground (above [zOPEN](#)) on its CC pins.

4.5.2.2.1.2 Exiting From Disabled State

A UFP shall transition to [Unattached.UFP](#) when directed.

A DFP shall transition to [Unattached.DFP](#) when directed.

A DRP shall transition to either [Unattached.UFP](#) or [Unattached.DFP](#) when directed.

4.5.2.2.2 ErrorRecovery State

This state appears in Figure 4-12, Figure 4-13, Figure 4-14, Figure 4-15 and Figure 4-16.

The ErrorRecovery state is where the port cycles its connection by removing all terminations from the CC pins for [tErrorRecovery](#) followed by transitioning to the appropriate [Unattached.UFP](#) or [Unattached.DFP](#) state based on port type.

The port should transition to the ErrorRecovery state from any other state when directed.

A port may choose not to support the ErrorRecovery state. If the ErrorRecovery state is not supported, the port shall be directed to the [Disabled](#) state if supported. If the Disabled state is not supported, the port shall be directed to either the [Unattached.UFP](#) or [Unattached.DFP](#) states.

4.5.2.2.2.1 ErrorRecovery State Requirements

The source port ([Rp](#)) shall not drive VBUS or VCONN.

The sink port ([Rd](#)) shall present a high-impedance to ground (above [zOPEN](#)) on its CC pins.

4.5.2.2.2.2 Exiting From ErrorRecovery State

A UFP shall transition to [Unattached.UFP](#) after [tErrorRecovery](#).

A DFP shall transition to [Unattached.DFP](#) after [tErrorRecovery](#).

A DRP shall transition to either [Unattached.UFP](#) or [Unattached.DFP](#) after [tErrorRecovery](#).

4.5.2.2.3 Unattached.UFP State

This state appears in Figure 4-13, Figure 4-14, Figure 4-15 and Figure 4-16.

When in the [Unattached.UFP](#) state, the port is waiting to detect the presence of a DFP.

A port with a dead battery shall enter this state while unpowered. This allows it to charge by transitioning to [Attached.UFP](#) when a DFP is attached.

4.5.2.2.3.1 Unattached.UFP Requirements

The port shall not drive VBUS or VCONN.

Both CC pins shall be independently terminated to ground through [Rd](#).

4.5.2.2.3.2 Exiting from Unattached.UFP State

The port shall transition to [Attached.UFP](#) when VBUS is detected. The port shall not transition to [Attached.UFP](#) based on a change of voltage on one of its CC pins.

A DRP that does not support USB Power Delivery or strongly prefers the DFP role may optionally transition to [Try.DFP](#) instead of [Attached.UFP](#) when VBUS is detected.

A DRP shall transition to [Unattached.DFP](#) within [tDRPTransition](#) after $tDRP - dcDFP.DRP \cdot tDRP$ or if VBUS is detected or if directed.

A UFP with accessory support shall transition to [Unattached.Accessory](#) within [tDRPTransition](#) after $dcDFP.DRP \cdot tDRP$ or if directed.

4.5.2.2.4 Attached.UFP State

This state appears in Figure 4-13, Figure 4-14, Figure 4-15 and Figure 4-16.

When in the [Attached.UFP](#) state, the port is attached and operating as a UFP.

4.5.2.2.4.1 Attached.UFP Requirements

Since only one CC pin is connected through the cable, only one CC pin will be within the [vRd-Connect](#) range. The port shall continue to terminate this CC pin to ground through [Rd](#).

If the port supports signaling on USB SuperSpeed pairs, it shall functionally connect the USB SuperSpeed pairs.

The port shall meet the [UFP Power Sub-State](#) requirements specified in Section 4.5.2.3.

The port may negotiate a [USB PD PR_Swap](#). When the port successfully completes a [USB PD PR_Swap](#), it shall source current on the CC pin connected through the cable and monitor its voltage.

The port may act as a VBUS power source either as a result of a [USB PD PR_Swap](#), or may continue to act as a power source when entering the [Attached.UFP](#) state from the [Attached.DFP](#) state after a [USB PD DR_Swap](#).

VCONN by default shall not be supplied by the UFP. A [USB PD VCONN_Swap](#) may be used to change the port sourcing VCONN to the UFP. A [USB PD DR_Swap](#) or [PR_Swap](#) shall not change the port sourcing VCONN.

4.5.2.2.4.2 Exiting from Attached.UFP State

A port that is acting as a power sink shall transition to [Unattached.UFP](#) when VBUS is no longer present.

For a port that has completed a [USB PD PR_Swap](#) and as a result is sourcing VBUS:

- The port shall transition to [Unattached.UFP](#) when the voltage on the monitored CC pin is within the [vOPEN](#) range. The UFP may de-bounce for [tPDDebounce](#).
- The port shall cease to supply VBUS within [tVBUSOFF](#) of exiting Attached.UFP.

A port that is supplying VCONN shall cease to supply it within [tVCONNOff](#) of exiting Attached.UFP, unless it is exiting as a result of a [USB PD DR_Swap](#).

A port that negotiates a [USB PD DR_Swap](#) shall transition to [Attached.DFP](#), and maintains its power role and CC termination.

If the port supports [Audio Adapter Accessory Mode](#) or [Debug Accessory Mode](#) and is acting as a power sink, it shall transition to [Accessory.Present](#) if the voltage on both CC pins is within the [vRa](#) range for longer than [tAccDetect](#).

4.5.2.2.5 Accessory.Present State

This state appears in Figure 4-14 and Figure 4-16.

If a port enters [Attached.UFP](#) but does not detect [Rp](#) on either of the CC pins, this means an accessory is attached.

4.5.2.2.5.1 Accessory.Present Requirements

In order to establish a proper termination on the CC pins for detecting which accessory is attached, the port shall advertise Default USB Power (see Table 4-10) on both CC pins independently.

The port may sink current over VBUS from the accessory, but shall not draw more than 500 mA from VBUS.

4.5.2.2.5.2 Exiting from Accessory.Present

The port shall transition to [AudioAccessory](#) when the voltage on both CC pins is within the [vRa](#) range for longer than [tCCDebounce](#).

The port shall transition to [DebugAccessory](#) when the voltage on both CC pins is within the [vRd](#) range for longer than [tCCDebounce](#).

The port shall transition to [Unattached.UFP](#) if VBUS is no longer present.

4.5.2.2.6 Unattached.DFP State

This state appears in Figure 4-12, Figure 4-15 and Figure 4-16.

When in the Unattached.DFP state, the port is waiting to detect the presence of a UFP.

4.5.2.2.6.1 Unattached.DFP Requirements

The port shall not drive VBUS or VCONN.

The port shall source current on both CC pins independently.

In order to establish a proper termination on the CC pins for detecting the attach of a UFP, the port shall provide an [Rp](#) that falls between the maximum resistance for Default USB Power and the minimum resistance for 3.0 A, alternatively between the minimum current for Default USB Power and the maximum current for 3.0 A, as specified in Table 4-10.

4.5.2.2.6.2 Exiting from Unattached.DFP State

If the port is not operating in DRP mode, it shall transition to [Attached.DFP](#) when the voltage on exactly one of the CC pins is within the [vRd](#) range for longer than [tCCDebounce](#).

A DRP shall transition to [Attach.DFP.DRPWait](#) when the voltage on exactly one of the CC pins is within the [vRd](#) range for longer than [tCCDebounce](#).

A DRP shall transition to [Unattached.UFP](#) within [tDRPTransition](#) after $\text{dcDFP.DRP} \cdot \text{tDRP}$ or if VBUS is detected or if directed.

If the port supports Audio Adapter Accessory Mode, it shall transition to [AudioAccessory](#) when both CC pins are within the [vRa](#) range for longer than [tAccDetect](#).

If the port supports Debug Accessory Mode, it shall transition to [DebugAccessory](#) when both CC pins are within the [vRd](#) range for longer than [tAccDetect](#).

4.5.2.2.7 Attached.DFP State

This state appears in Figure 4-12, Figure 4-15 and Figure 4-16.

When in the Attached.DFP state, the port is attached and operating as a DFP.

4.5.2.2.7.1 Attached.DFP Requirements

Since only one CC pin is connected through the cable, only one CC pin will be within the [vRd](#) range. The port shall source current on this CC pin and monitor its voltage.

The port shall advertise one of the three levels of VBUS power capability as specified in Table 4-10. The port may change its VBUS power capability advertisement at any time.

The port shall supply VBUS within [tVBUSON](#) of entering this state, and for as long as it is operating as a power source.

If the port supports signaling on USB SuperSpeed pairs, it shall:

- Functionally connect the USB SuperSpeed pairs
- For VCONN, do one of two things:
 - Apply VCONN unconditionally to the unused CC pin, or
 - Apply VCONN to the unused CC pin if the voltage on the unused CC pin is within the [vRa](#) range for longer than [tCCDebounce](#).

A port that does not support signaling on USB SuperSpeed pairs may supply VCONN in the same manner described above.

If the port supplies VCONN, it shall do so within [tVCONNON](#).

The port shall not supply VCONN if it has entered this state as a result of a [USB PD](#) DR_Swap, and was not previously supplying VCONN.

The port may negotiate a [USB PD](#) PR_Swap. When the port successfully completes a [USB PD](#) PR_Swap, it shall terminate the CC pin connected through the cable to ground through [Rd](#).

The port may act as a power sink as a result of either a [USB PD](#) PR_Swap, or by entering the Attached.DFP state from the [Attached.UFP](#) state after a [USB PD](#) DR_Swap. A port that is acting as a power sink shall not supply VBUS.

The port may negotiate a [USB PD VCONN_Swap](#). When the port successfully executes [USB PD VCONN_Swap](#) operation, it shall stop sourcing VCONN within [tVCONNOFF](#).

4.5.2.2.7.2 Exiting from Attached.DFP State

A DFP shall transition to [Unattached.DFP](#) when the voltage on the monitored CC pin is within the [vOPEN](#) range. The DFP may de-bounce for [tPDDebounce](#).

A DRP shall transition to [Lock.UFP](#) when the voltage on the monitored CC pin is within the [vOPEN](#) range. The DFP may de-bounce for [tPDDebounce](#).

A port that is supplying VBUS shall cease to supply it within [tVBUSOFF](#) of exiting Attached.DFP.

A port that is supplying VCONN shall cease to supply it within [tVCONNOFF](#) of exiting Attached.DFP, unless it is exiting as a result of a [USB PD DR_Swap](#).

For a port that has completed a [USB PD PR_Swap](#) and as a result is sinking VBUS, the port shall transition to [Unattached.DFP](#) when VBUS is no longer present.

A DRP that negotiates a [USB PD DR_Swap](#) shall transition to [Attached.UFP](#), and continue to act as a VBUS and VCONN source, and maintain its CC termination.

4.5.2.2.8 Attach.DFP.DRPWait State

This state appears in Figure 4-15 and Figure 4-16.

The Attach.DFP.DRPWait state is used to halt the UFP/DFP toggling for a period of [tDRPHold](#) once a DRP detects the presence of a UFP. This ensures that both ports have a chance to resolve to their respective roles.

The requirements for this state are identical to [Attached.DFP](#), except that [USB PD PR_Swap](#), [USB PD DR_Swap](#) and [USB PD VCONN_Swap](#) are not permitted.

4.5.2.2.8.1 Attach.DFP.DRPWait Requirements

Since only one CC pin is connected through the cable, only one CC pin will be within the [vRd](#) range. The port shall source current on this CC pin.

The port shall advertise one of the three levels of VBUS power capability as specified in Table 4-10. The port may change its VBUS power capability advertisement at any time.

The port shall supply VBUS within [tVBUSON](#).

If the port supports signaling on USB SuperSpeed pairs, it shall:

- Functionally connect the USB SuperSpeed pairs
- For VCONN, do one of two things:
 - Apply VCONN unconditionally to the unused CC pin, or
 - Apply VCONN to the unused CC pin if the voltage on the unused CC pin is within the [vRa](#) range for longer than [tCCDebounce](#).

A port that does not support signaling on USB SuperSpeed pairs may supply VCONN in the same manner described above.

If the port supplies VCONN, it shall do so within [tVCONNON](#).

The port shall not negotiate a [USB PD](#) PR_Swap, a [USB PD](#) DR_Swap or a [USB PD](#) VCONN_Swap until after it has entered the [Attached.DFP](#) state.

4.5.2.2.8.2 Exiting from Attach.DFP.DRPWait State

The port shall transition to [Attached.DFP](#) after [tDRPHold](#).

4.5.2.2.9 Lock.UFP State

This state appears in Figure 4-15 and Figure 4-16.

When a DRP sees a UFP removed, the DRP maintains the Lock.UFP state to avoid juggling the DFP role with its port partner.

4.5.2.2.9.1 Lock.UFP Requirements

The port shall not drive VBUS or VCONN.

Both CC pins shall be independently terminated to ground through [Rd](#).

4.5.2.2.9.2 Exiting from Lock.UFP State

The port shall transition to [Attached.UFP](#) when VBUS is detected.

The port shall transition to [Unattached.DFP](#) after [tDRPLock](#).

4.5.2.2.10 Try.DFP State

This state appears in Figure 4-16.

When in the Try.DFP state, the port is querying to determine if the port partner supports the UFP role.

4.5.2.2.10.1 Try.DFP Requirements

The port shall not drive VBUS or VCONN.

The port shall source current on both CC pins independently.

The port shall advertise one of the three levels of VBUS power capability as specified in Table 4-10. The port may change its VBUS power capability advertisement at any time.

4.5.2.2.10.2 Exiting from Try.DFP State

A DRP shall transition to [Attach.DFP.DRPWait](#) when the voltage on exactly one of the CC pins is within the [vRd](#) range for longer than [tCCDebounce](#).

A DRP shall transition to [Lock.UFP](#) after [tDRPTry](#).

4.5.2.2.11 Unattached.Accessory State

This state appears in Figure 4-14.

The Unattached.Accessory state allows accessory-supporting UFPs to connect to accessories, or to power Alternate Mode accessories from VCONN.

This state is functionally equivalent to the [Unattached.DFP](#) state in a DRP, except that [Attached.DFP](#) is not supported.

4.5.2.2.11.1 Unattached.Accessory Requirements

The port shall not drive VBUS or VCONN.

In order to establish a proper termination on the CC pins independently for detecting the attach of an accessory, the port shall provide an R_p that falls between the maximum resistance for Default USB Power and the minimum resistance for 3.0 A, alternatively between the minimum current for Default USB Power and the maximum current for 3.0 A, as specified in Table 4-10.

4.5.2.2.11.2 Exiting from Unattached.Accessory State

The port shall transition to [Unattached.UFP](#) within [tDRPTransition](#) after $dcDFP.DRP \cdot tDRP$.

If the port supports Audio Adapter Accessory Mode, it shall transition to [AudioAccessory](#) when the voltage on both CC pins is within the [vRa](#) range for longer than [tAccDetect](#).

If the port supports Debug Accessory Mode, it shall transition to [DebugAccessory](#) when the voltage on both CC pins is within the [vRd](#) range for longer than [tAccDetect](#).

If the port supports VCONN-powered accessories, it shall transition to [Powered.Accessory](#) when the voltage on one of the CC pins is within the [vRd](#) range for longer than [tCCDebounce](#) and the voltage on the other CC pin is within the [vRa](#) range for longer than [tCCDebounce](#).

4.5.2.2.12 AudioAccessory State

This state appears in Figure 4-12, Figure 4-14 and Figure 4-16.

The AudioAccessory state is used for the [Audio Adapter Accessory Mode](#) specified in Appendix A.

4.5.2.2.12.1 AudioAccessory Requirements

The port shall reconfigure its pins as detailed in Appendix A.

A port that sinks current from the audio accessory over VBUS shall not draw more than 500 mA.

The port shall advertise Default USB Power (see Table 4-10) on both CC pins independently.

The port shall monitor at least one of the CC pins to detect when the voltage is no longer inside the [vRa](#) range.

4.5.2.2.12.2 Exiting from AudioAccessory State

If the port is a UFP, the port shall transition to [Unattached.UFP](#) when the voltage of the monitored CC pins is outside the [vRa](#) range for longer than [tCCDebounce](#) and VBUS is not being supplied from the accessory.

If the port is a DFP or DRP, the port shall transition to [Unattached.DFP](#) when the voltage of the monitored CC pins is outside the [vRa](#) range for longer than [tCCDebounce](#) and VBUS is not being supplied from the accessory.

4.5.2.2.13 DebugAccessory

This state appears in Figure 4-12, Figure 4-14 and Figure 4-16.

The DebugAccessory state is used for the [Debug Accessory Mode](#) specified in Appendix B.

4.5.2.2.13.1 DebugAccessory Requirements

This mode is for debug only and shall not be used for communicating with commercial products.

The port shall advertise Default USB Power (see Table 4-10) on both CC pins independently.

The port shall monitor at least one of the CC pins to detect when the voltage rises above the [vRd](#) range.

4.5.2.2.13.2 Exiting from DebugAccessory State

If the port is a UFP, the port shall transition to [Unattached.UFP](#) when the voltage of the monitored CC pins is outside the [vRd](#) range for longer than [tPDDebounce](#) and VBUS is not being supplied from the accessory.

If the port is a DFP or DRP, the port shall transition to [Unattached.DFP](#) when the voltage of the monitored CC pins is outside the [vRd](#) range for longer than [tPDDebounce](#) and VBUS is not being supplied from the accessory.

4.5.2.2.14 Powered.Accessory State

This state appears in Figure 4-14.

When in the Powered.Accessory state, the port is powering a [VCONN-Powered Accessory](#).

4.5.2.2.14.1 Powered.Accessory Requirements

Since only one CC pin is connected through the cable, only one CC pin will be within the [vRd](#) range. The port shall advertise Default USB Power (see Table 4-10) on this CC pin and monitor its voltage.

The port shall supply VCONN (2.7 V minimum) on the unused CC pin within [tVconnON-PA](#) of entering the Powered.Accessory state.

The port shall not drive VBUS.

The port shall use [USB Power Delivery](#) Structured Vendor Defined Messages (Structured VDMs) to identify the accessory and enter an Alternate Mode.

4.5.2.2.14.2 Exiting from Powered.Accessory State

The port shall transition to [Unattached.UFP](#) when the voltage on the monitored CC pin is outside the [vRd](#) range for longer than [tPDDebounce](#).

The port shall transition to [Unsupported.Accessory](#) if it does not successfully enter an Alternate Mode within [tAMTimeout](#) (see Section 5.1).

The port shall cease to supply VCONN within [tVCONNOff](#) of exiting the Powered.Accessory state.

4.5.2.2.15 Unsupported.Accessory State

This state appears in Figure 4-14.

If a VCONN-powered accessory does not enter an Alternate Mode, the Unsupported.Accessory state is used to wait until the accessory is unplugged before continuing.

4.5.2.2.15.1 Unsupported.Accessory Requirements

Since only one CC pin is connected through the cable, only one CC pin will be within the [vRd](#) range. The port shall advertise Default USB Power (see Table 4-10) on this CC pin and monitor its voltage.

The port shall not drive VBUS or VCONN.

4.5.2.2.15.2 Exiting from Unsupported.Accessory

The port shall transition to [Unattached.UFP](#) when the voltage on the monitored CC pin is outside the [vRd](#) range for longer than [tCCDebounce](#).

4.5.2.3 UFP Power Sub-State Requirements

When in the [Attached.UFP](#) state, and when the DFP is supplying default VBUS, the port shall operate in one of the sub-states shown in Figure 4-17. The initial UFP Power Sub-State is [PowerDefault.UFP](#). Subsequently, the UFP Power Sub-State is determined by DFP's USB Type-C current advertisement. The [Attached.UFP](#) shall remain within the UFP Power Sub-States until either VBUS is removed or a [USB PD](#) contract is established with the DFP.

Figure 4-17 UFP Power Sub-States

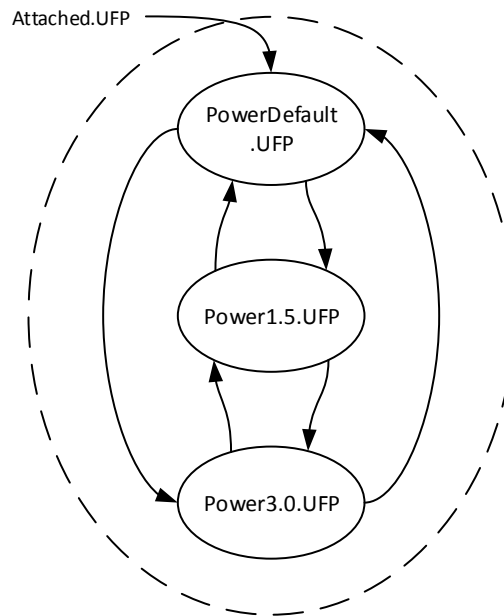

The UFP is only required to implement UFP Power Sub-State transitions if the UFP wants to consume more than default USB current.

4.5.2.3.1 PowerDefault.UFP Sub-State

This sub-state supports UFPs consuming current within the lowest range (default) of DFP-supplied current.

4.5.2.3.1.1 PowerDefault.UFP Requirements

The port shall draw no more than the default USB power from VBUS. See Section 4.6.2.1.

If the port wants to consume more than the default USB power, it shall monitor [vRd](#) to determine if more current is available from the DFP.

4.5.2.3.1.2 Exiting from PowerDefault.UFP

For any change on CC indicating a change in allowable power, the port shall not transition until the new [vRd](#) on CC has been stable for [tPDDebounce](#).

For a [vRd](#) in the [vRd-1.5](#) range, the port shall transition to the [Power1.5.UFP Sub-State](#).

For a [vRd](#) in the [vRd-3.0](#) range, the port shall transition to the [Power3.0.UFP Sub-State](#).

4.5.2.3.2 Power1.5.UFP Sub-State

This sub-state supports UFPs consuming current within the two lower ranges (default and 1.5 A) of DFP-supplied current.

4.5.2.3.2.1 Power1.5.UFP Requirements

The port shall draw no more than 1.5 A from VBUS.

The port shall monitor [vRd](#) while it is in this sub-state.

4.5.2.3.2.2 Exiting from Power1.5.UFP

For any change on CC indicating a change in allowable power, the port shall not transition until the new [vRd](#) on CC has been stable for [tPDDebounce](#).

For a [vRd](#) in the [vRd-USB](#) range, the port shall transition to the [PowerDefault.UFP Sub-State](#) and reduce its power consumption to the new range within [tSinkAdj](#).

For a [vRd](#) in the [vRd-3.0](#) range, the port shall transition to the [Power3.0.UFP Sub-State](#).

4.5.2.3.3 Power3.0.UFP Sub-State

This sub-state supports UFPs consuming current within all three ranges (default, 1.5 A and 3.0 A) of DFP-supplied current.

4.5.2.3.3.1 Power3.0.UFP Requirements

The port shall draw no more than 3.0 A from VBUS.

The port shall monitor [vRd](#) while it is in this sub-state.

4.5.2.3.3.2 Exiting from Power3.0.UFP

For any change on CC indicating a change in allowable power, the port shall not transition until the new [vRd](#) on CC has been stable for [tPDDebounce](#).

For a [vRd](#) in the [vRd-USB](#) range, the port shall transition to the [PowerDefault.UFP Sub-State](#) and reduce its power consumption to the new range within [tSinkAdj](#).

For a [vRd](#) in the [vRd-1.5](#) range, the port shall transition to the [Power1.5.UFP Sub-State](#) and reduce its power consumption to the new range within [tSinkAdj](#).

4.5.2.4 Connection States Summary

Table 4-8 defines the mandatory and optional states for each type of port.

Table 4-8 Mandatory and Optional States

	DFP	UFP	DRP
<u>Disabled</u>	Optional	Optional	Optional
<u>ErrorRecovery</u>	Optional	Optional	Optional
<u>Unattached.UFP</u>	N/A	Mandatory	Mandatory
<u>Attached.UFP</u>	N/A	Mandatory	Mandatory
<u>Unattached.DFP</u>	Mandatory	N/A	Mandatory
<u>Attached.DFP</u>	Mandatory	N/A	Mandatory
<u>Attach.DFP.DRPWait</u>	N/A	N/A	Mandatory
<u>Lock.UFP</u>	N/A	N/A	Mandatory
<u>Try.DFP</u>	N/A	N/A	Optional
<u>Accessory.Present</u>	N/A	Optional	Optional
<u>AudioAccessory</u>	Optional	Optional	Optional
<u>DebugAccessory</u>	Optional	Optional	Optional
<u>Unattached.Accessory</u>	N/A	Optional	N/A
<u>Powered.Accessory</u>	N/A	Optional	N/A
<u>Unsupported.Accessory</u>	N/A	Optional	N/A
<u>PowerDefault.UFP</u>	N/A	Mandatory	Mandatory
<u>Power1.5.UFP</u>	N/A	Optional	Optional
<u>Power3.0.UFP</u>	N/A	Optional	Optional

Support for [USB PD](#) and [USB PD](#) swapping mechanisms (PR_Swap, DR_Swap, and VCONN_Swap) are optional for all port types. When used, [USB PD](#) communications shall only occur within the following connection states:

- Attached.UFP
- Attached.DFP
- Powered.Accessory
- DebugAccessory

4.5.3 USB Port Interoperability Behavior

This section describes interoperability behavior between USB Type-C to USB Type-C ports and between USB Type-C to legacy USB ports.

4.5.3.1 USB Type-C Port to USB Type-C Port Interoperability Behaviors

The following sub-sections describe typical port-to-port interoperability behaviors for the various combinations of USB Type-C DFP, UFP and DRPs as presented in Table 4-4. In all of the described behaviors, the impact of [USB PD](#)-based swaps (PR_Swap, DR_Swap or VCONN_Swap) are not considered.

The figures in the following sections illustrate the CC1 and CC2 routing after the CC detection process is complete.

4.5.3.1.1 DFP to UFP Behavior

Figure 4-18 illustrates the functional model for a DFP connected to a UFP. The single CC wire that is in a standard cable is only shown in one of the four possible connection routes, CC1 to CC1.

Figure 4-18 DFP to UFP Functional Model

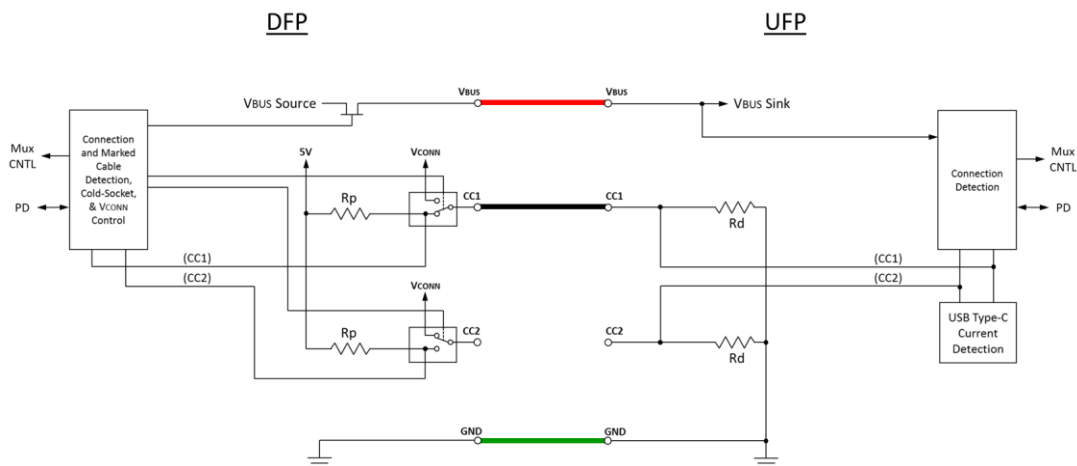

The following describes the behavior when a DFP is connected to a UFP.

1. DFP and UFP in the unattached state
2. DFP transitions from [Unattached.DFP](#) to [Attached.DFP](#)
 - DFP detects the UFP's pull-down on CC and enters [Attached.DFP](#)
 - DFP turns on VBUS and VCONN
3. UFP transitions from [Unattached.UFP](#) to [Attached.UFP](#)
 - UFP detects VBUS and enters [Attached.UFP](#)
4. While the DFP and UFP are in the attached state:
 - DFP adjusts [Rp](#) as needed to limit the current the UFP may draw
 - UFP detects and monitors [vRd](#) for available current on VBUS
 - DFP monitors CC for detach and when detected, enters [Unattached.DFP](#)
 - UFP monitors VBUS for detach and when detected, enters [Unattached.UFP](#)

4.5.3.1.2 DFP to DRP Behavior

Figure 4-19 illustrates the functional model for a DFP connected to a DRP. The single CC wire that is in a standard cable is only shown in one of the four possible connection routes, CC1 to CC1.

Figure 4-19 DFP to DRP Functional Model

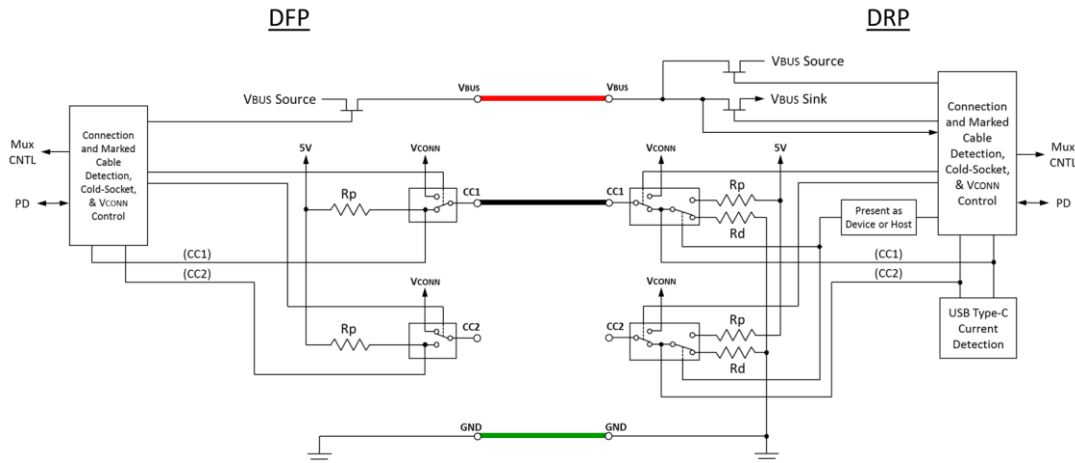

The following describes the behavior when a DFP is connected to a DRP.

1. DFP and DRP in the unattached state
 - DRP alternates between [Unattached.DFP](#) and [Unattached.UFP](#)
2. DFP transitions from [Unattached.DFP](#) to [Attached.DFP](#)
 - DFP detects the DRP's pull-down on CC and enters [Attached.DFP](#)
 - DFP turns on VBUS and VCONN
3. DRP transitions from [Unattached.UFP](#) to [Attached.UFP](#)
 - DRP in [Unattached.UFP](#) detects VBUS and enters [Attached.UFP](#)
4. While the DFP and DRP are in their respective attached states:
 - DFP adjusts R_p as needed to limit the current the UFP may draw
 - DRP detects and monitors v_{Rd} for available current on VBUS
 - DFP monitors CC for detach and when detected, enters [Unattached.DFP](#)
 - DRP monitors VBUS for detach and when detected, enters [Unattached.UFP](#) (and resumes toggling between [Unattached.UFP](#) and [Unattached.DFP](#))

4.5.3.1.3 DRP to UFP Behavior

Figure 4-20 illustrates the functional model for a DRP connected to a UFP. The single CC wire that is in a standard cable is only shown in one of the four possible connection routes, CC1 to CC1.

Figure 4-20 DRP to UFP Functional Model

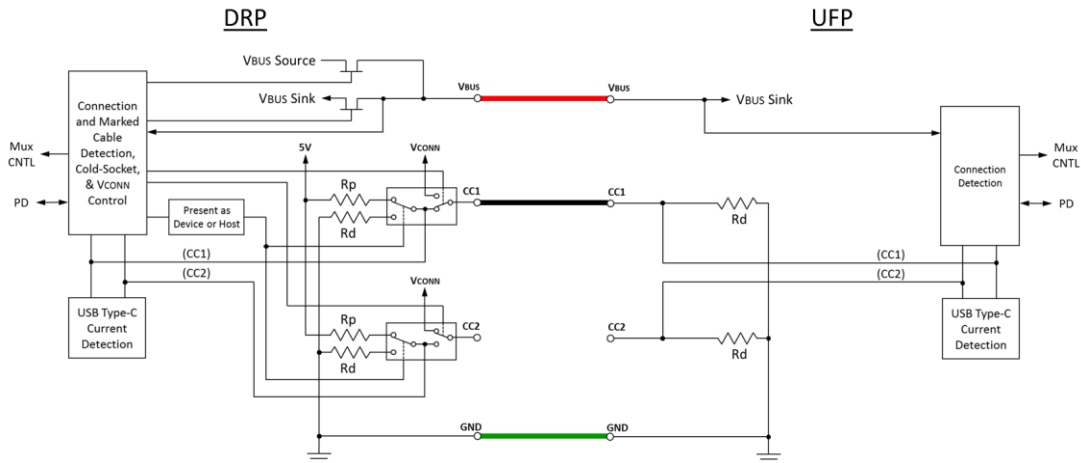

The following describes the behavior when a DRP is connected to a UFP.

1. DRP and UFP in the unattached state
 - DRP alternates between [Unattached.DFP](#) and [Unattached.UFP](#)
2. DRP transitions from [Unattached.DFP](#) to [Attach.DFP.DRPWait](#)
 - DRP in [Unattached.DFP](#) detects the UFP in [Unattached.UFP](#)'s pull-down on CC and enters [Attach.DFP.DRPWait](#)
 - DRP in [Attach.DFP.DRPWait](#) turns on VBUS and VCONN
3. UFP transitions from [Unattached.UFP](#) to [Attached.UFP](#)
 - UFP detects VBUS and enters [Attached.UFP](#)
4. DRP transitions from [Attach.DFP.DRPWait](#) to [Attached.DFP](#)
 - DRP in [Attach.DFP.DRPWait](#) times out ($t_{DRPHold}$) and transitions to [Attached.DFP](#)
5. While the DRP and UFP are in their respective attached states:
 - DRP adjusts R_p as needed to limit the current the UFP may draw
 - UFP detects and monitors v_{Rd} for available current on VBUS
 - DRP monitors CC for detach and when detected, enters [Lock.UFP](#)
 - DRP in [Lock.UFP](#) times out ($t_{DRPLock}$) and transitions to [Unattached.DFP](#) (and resumes toggling between [Unattached.UFP](#) and [Unattached.DFP](#))
 - UFP monitors VBUS for detach and when detected, enters [Unattached.UFP](#)

4.5.3.1.4 DRP to DRP Behavior

Two behavior descriptions based on the connection state diagrams are provided below. In the first case, the two DRPs accept the resulting DFP-to-UFP relationship achieved randomly

whereas in the second case the DRP #2 chooses to drive the random result to the opposite result using the [Try.DFP](#) mechanism.

Figure 4-21 illustrates the functional model for a DRP connected to a DRP in the first case described. The single CC wire that is in a standard cable is only shown in one of the four possible connection routes, CC1 to CC1. Port numbers have been arbitrarily assigned in the diagram to assist the reader to understand the process description.

Figure 4-21 DRP to DRP Functional Model – CASE 1

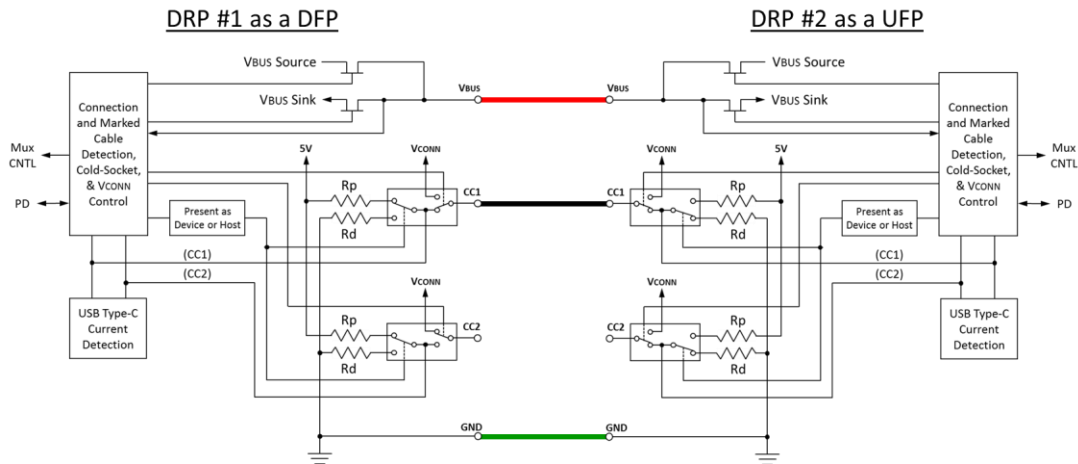

CASE 1: The following describes the behavior when a DRP is connected to another DRP. In this flow, the two DRPs accept the resulting DFP-to-UFP relationship achieved randomly.

1. Both DRPs in the unattached state
 - DRP #1 and DRP #2 alternate between [Unattached.DFP](#) and [Unattached.UFP](#)
2. DRP #1 transitions from [Unattached.DFP](#) to [Attach.DFP.DRPWait](#)
 - DRP #1 in [Unattached.DFP](#) detects the DRP #2 in [Unattached.UFP](#)'s pull-down on CC and enters [Attach.DFP.DRPWait](#)
 - DRP #1 in [Attach.DFP.DRPWait](#) turns on VBUS and VCONN
3. DRP #2 transitions from [Unattached.UFP](#) to [Attached.UFP](#)
 - DRP #2 in [Unattached.UFP](#) detects VBUS and enters [Attached.UFP](#)
4. DRP #1 transitions from [Attach.DFP.DRPWait](#) to [Attached.DFP](#)
 - DRP #1 in [Attach.DFP.DRPWait](#) times out ([tDRPHold](#)) and transitions to [Attached.DFP](#)
5. While the DRPs are in their respective attached states:
 - DRP #1 adjusts [Rp](#) as needed to limit the current DRP #2 may draw
 - DRP #2 detects and monitors [vRd](#) for available current on VBUS
 - DRP #1 monitors CC for detach and when detected, enters [Lock.UFP](#)
 - DRP #1 in [Lock.UFP](#) times out ([tDRPLock](#)) and transitions to [Unattached.DFP](#) (and resumes toggling between [Unattached.UFP](#) and [Unattached.DFP](#))
 - DRP #2 monitors VBUS for detach and when detected, enters [Unattached.UFP](#) (and resumes toggling between [Unattached.UFP](#) and [Unattached.DFP](#))

Figure 4-22 illustrates the functional model for a DRP connected to a DRP in the second case described.

Figure 4-22 DRP to DRP Functional Model – CASE 2

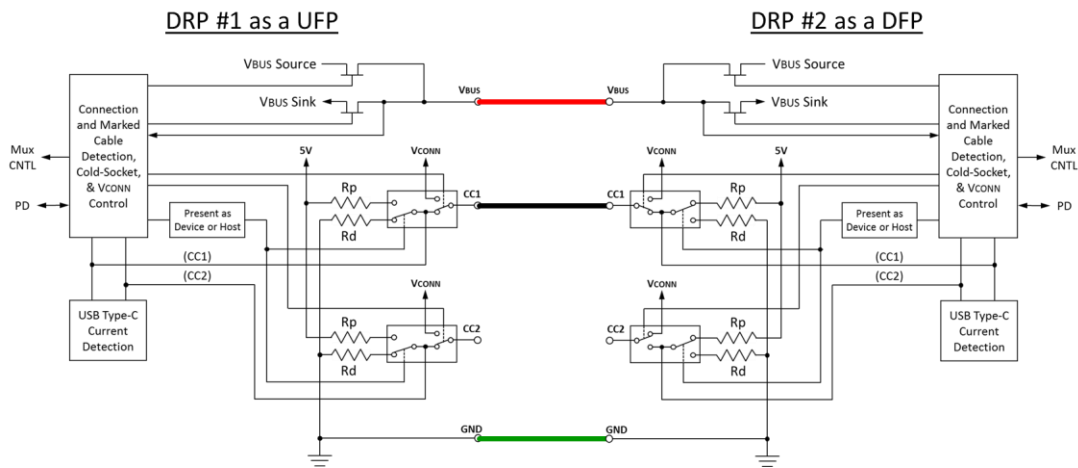

CASE 2: The following describes the behavior when a DRP is connected to another DRP. In this flow, the DRP #2 chooses to drive the random result to the opposite result using the [Try.DFP](#) mechanism.

1. Both DRPs in the unattached state
 - DRP #1 and DRP #2 alternate between [Unattached.DFP](#) and [Unattached.UFP](#)
2. DRP #1 transitions from [Unattached.DFP](#) to [Attach.DFP.DRPWait](#)
 - DRP #1 in [Unattached.DFP](#) detects the DRP #2 in [Unattached.UFP](#)'s pull-down on CC and enters [Attach.DFP.DRPWait](#)
 - DRP #1 in [Attach.DFP.DRPWait](#) turns on VBUS and VCONN
3. DRP #2 transitions from [Unattached.UFP](#) to [Try.DFP](#)
 - DRP #2 in [Unattached.UFP](#) detects VBUS but strongly prefers the DFP role, so transitions to [Try.DFP](#)
 - DRP #2 in [Try.DFP](#) asserts a pull-up on CC and waits
4. DRP #1 transitions from [Attach.DFP.DRPWait](#) to [Lock.UFP](#) via [Attached.DFP](#)
 - DRP #1 in [Attach.DFP.DRPWait](#) times out ([tDRPHold](#)) and transitions to [Attached.DFP](#)
 - DRP #1 in [Attached.DFP](#) no longer detects DRP #2's pull-down on CC and transitions to [Lock.UFP](#).
 - DRP #1 in [Lock.UFP](#) turns off VBUS and VCONN and applies a pull-down on CC
5. DRP #2 transitions from [Try.DFP](#) to [Attached.DFP](#) via [Attach.DFP.DRPWait](#)
 - DRP #2 in [Try.DFP](#) detects the DRP #1 in [Lock.UFP](#)'s pull-down on CC and enters [Attach.DFP.DRPWait](#)
 - DRP #2 in [Attach.DFP.DRPWait](#) turns on VBUS
 - DRP #2 in [Attach.DFP.DRPWait](#) times out ([tDRPHold](#)) and transitions to [Attached.DFP](#)

- DRP #2 in [Attached.DFP](#) turns on VCONN
6. DRP #1 transitions from [Lock.UFP](#) to [Attached.UFP](#)
 - DRP #1 in [Lock.UFP](#) detects VBUS and enters [Attached.UFP](#)
 7. While the DRPs are in their respective attached states:
 - DRP #2 adjusts R_p as needed to limit the current DRP #1 may draw
 - DRP #1 detects and monitors v_{Rd} for available current on VBUS
 - DRP #2 monitors CC for detach and when detected, enters [Lock.UFP](#)
 - DRP #2 in [Lock.UFP](#) times out ($t_{DRPLock}$) and transitions to [Unattached.DFP](#) (and resumes toggling between [Unattached.UFP](#) and [Unattached.DFP](#))
 - DRP #1 monitors VBUS for detach and when detected, enters [Unattached.UFP](#) (and resumes toggling between [Unattached.UFP](#) and [Unattached.DFP](#))

4.5.3.1.5 DFP to DFP Behavior

Figure 4-23 illustrates the functional model for a DFP connected to a DFP. The single CC wire that is in a standard cable is only shown in one of the four possible connection routes, CC1 to CC1. Port numbers have been arbitrarily assigned in the diagram to assist the reader to understand the process description.

Figure 4-23 DFP to DFP Functional Model

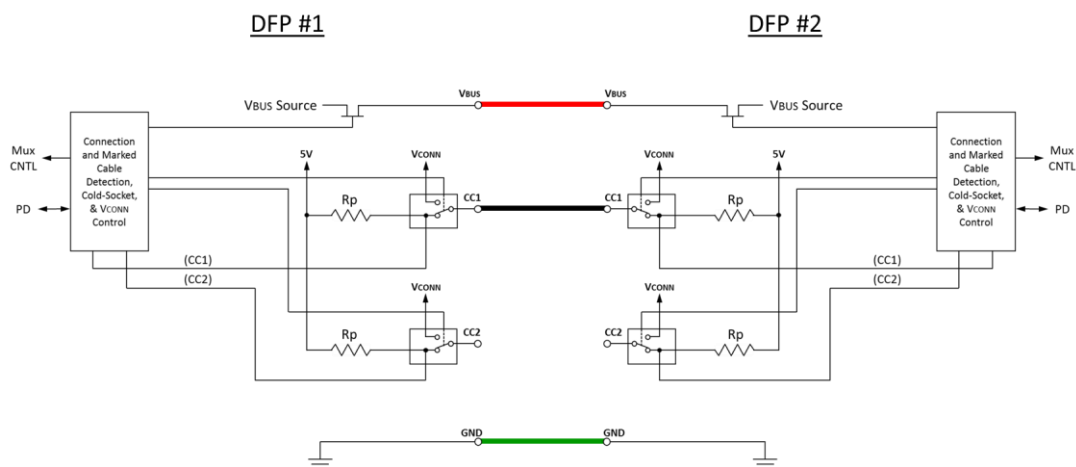

The following describes the behavior when a DFP is connected to another DFP.

1. Both DFPs in the unattached state
 - DFP #1 fails to detect a UFP's pull-down on CC and remains in [Unattached.DFP](#)
 - DFP #2 fails to detect a UFP's pull-down on CC and remains in [Unattached.DFP](#)

4.5.3.1.6 UFP to UFP Behavior

Figure 4-24 illustrates the functional model for a UFP connected to a UFP. The single CC wire that is in a standard cable is only shown in one of the four possible connection routes, CC1 to CC1. Port numbers have been arbitrarily assigned in the diagram to assist the reader to understand the process description.

Figure 4-24 UFP to UFP Functional Model

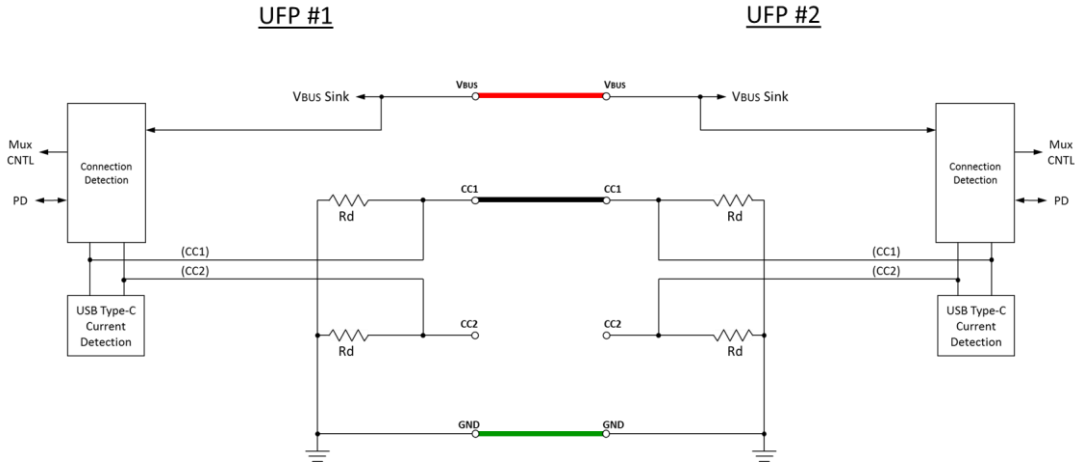

The following describes the behavior when a UFP is connected to another UFP.

1. Both UFPs in the unattached state

- UFP #1 fails to detect VBUS supplied by a DFP and remains in [Unattached.UFP](#)
- UFP #2 fails to detect VBUS supplied by a DFP and remains in [Unattached.UFP](#)

4.5.3.2 USB Type-C port to Legacy Port Interoperability Behaviors

The following sub-sections describe port-to-port interoperability behaviors for the various combinations of USB Type-C DFP, UFP and DRPs and legacy USB ports.

4.5.3.2.1 DFP to Legacy Device Port Behavior

Figure 4-25 illustrates the functional model for a DFP connected to a legacy device port. This model is based on having an adapter present as a UFP to the DFP. This adapter has a USB Type-C plug on one end plugged into the DFP and either a USB Standard-B plug, USB Micro-B plug, USB Mini-B plug, or a USB Standard-A receptacle on the other end.

Figure 4-25 DFP to Legacy Device Port Functional Model

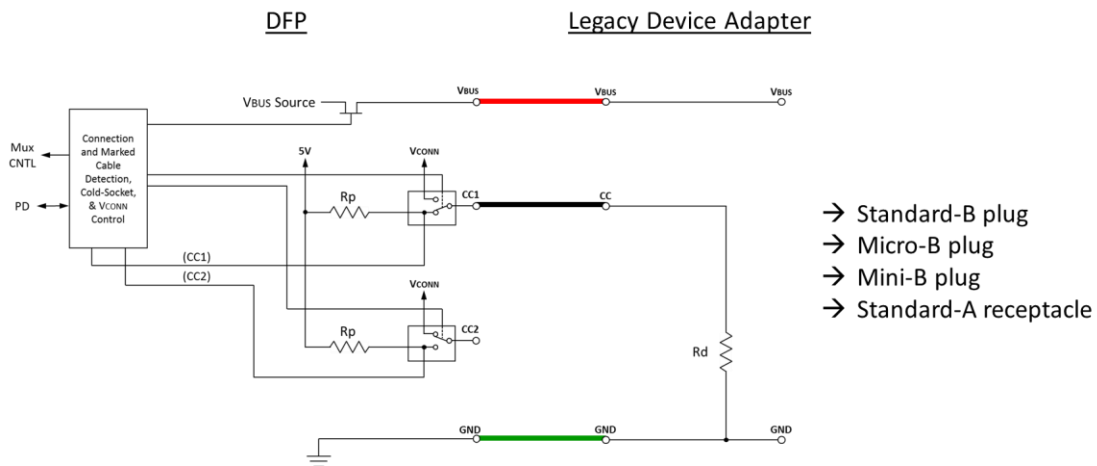

The following describes the behavior when a DFP is connected to a legacy device adapter that has an [Rd](#) to ground so as to mimic the behavior of a UFP.

1. DFP in the unattached state
2. DFP transitions from [Unattached.DFP](#) to [Attached.DFP](#)
 - DFP detects the adapter's pull-down on CC and enters [Attached.DFP](#)
 - DFP turns on VBUS and VCONN
3. While the DFP is in the attached state:
 - DFP monitors CC for detach and when detected, enters [Unattached.DFP](#)

4.5.3.2.2 Legacy Host Port to UFP Behavior

Figure 4-26 illustrates the functional model for a legacy host port connected to a UFP. This model is based on having an adapter that presents itself as a host to the UFP, this adapter is either a USB Standard-A legacy plug or a USB Micro-B legacy receptacle on one end and the USB Type-C plug on the other end plugged into a UFP.

Figure 4-26 Legacy Host Port to UFP Functional Model

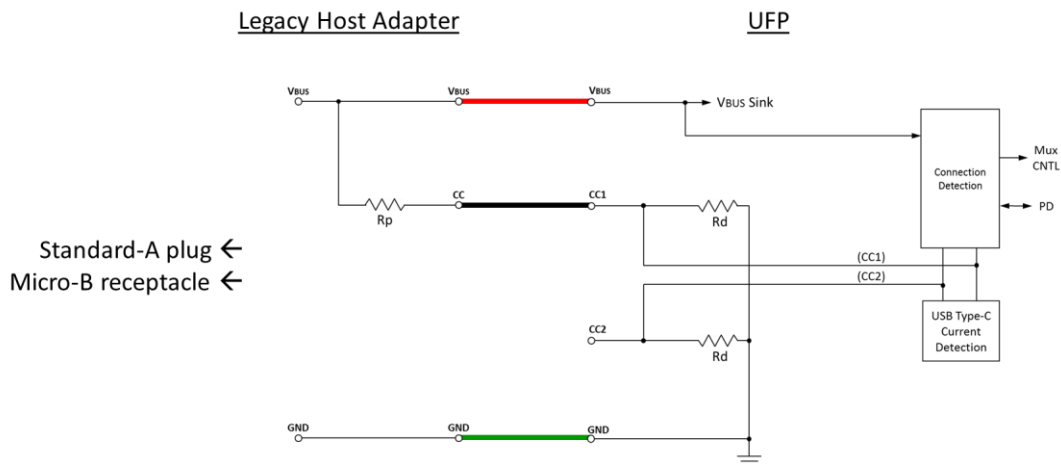

The following describes the behavior when a legacy host adapter that has an [Rp](#) to VBUS so as to mimic the behavior of a DFP that is connected to a UFP. The value of [Rp](#) shall indicate an advertisement of Default USB Power (See Table 4-10).

1. UFP in the unattached state
2. UFP transitions from [Unattached.UFP](#) to [Attached.UFP](#)
 - UFP detects VBUS and enters [Attached.UFP](#)
3. While the UFP is in the attached state:
 - UFP monitors VBUS for detach and when detected, enters [Unattached.UFP](#)

USB Type-C-based products that support [USB PD](#) BFSK are responsible for protecting the CC inputs from voltages greater than 5 V – see Section 4.6.2.4.

4.5.3.2.3 DRP to Legacy Device Port Behavior

Figure 4-27 illustrates the functional model for a DRP connected to a legacy device port. This model is based on having an adapter present as a UFP to the DRP. This adapter has a USB Type-C plug on one end plugged into a DRP and either a USB Standard-B plug, USB Micro-B plug, USB Mini-B plug, or a USB Standard-A receptacle on the other end.

Figure 4-27 DRP to Legacy Device Port Functional Model

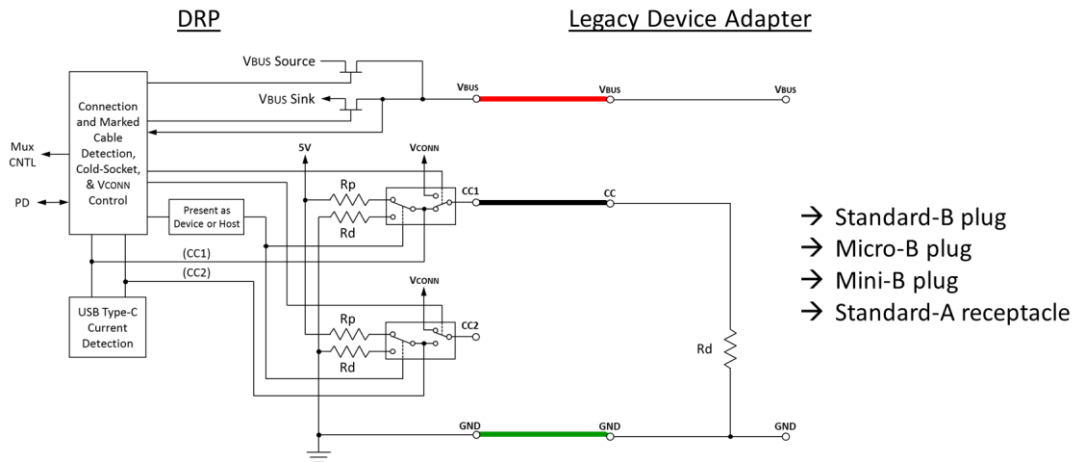

The following describes the behavior when a DRP is connected to a legacy device adapter that has an [Rd](#) to ground so as to mimic the behavior of a UFP.

1. DRP in the unattached state
 - DRP alternates between [Unattached.DFP](#) and [Unattached.UFP](#)
2. DRP transitions from [Unattached.DFP](#) to [Attached.DFP](#)
 - DRP in [Unattached.DFP](#) detects the adapter's pull-down on CC and enters [Attach.DFP.DRPWait](#)
 - DRP in [Attach.DFP.DRPWait](#) turns on VBUS and VCONN
 - DRP in [Attach.DFP.DRPWait](#) times out ([tDRPHold](#)) and transitions to [Attached.DFP](#)
3. While the DRP is in the attached state:
 - DRP monitors CC for detach and when detected, enters [Lock.UFP](#)
 - DRP in [Lock.UFP](#) times out ([tDRPLock](#)) and transitions to [Unattached.DFP](#) (and resumes toggling between [Unattached.UFP](#) and [Unattached.DFP](#))

4.5.3.2.4 Legacy Host Port to DRP Behavior

Figure 4-28 illustrates the functional model for a legacy host port connected to a DRP operating as a UFP. This model is based on having an adapter that presents itself as a host to the DRP operating as a UFP, this adapter is either a USB Standard-A legacy plug or a USB Micro-B legacy receptacle on one end and the USB Type-C plug on the other end plugged into a DRP.

Figure 4-28 Legacy Host Port to DRP Functional Model

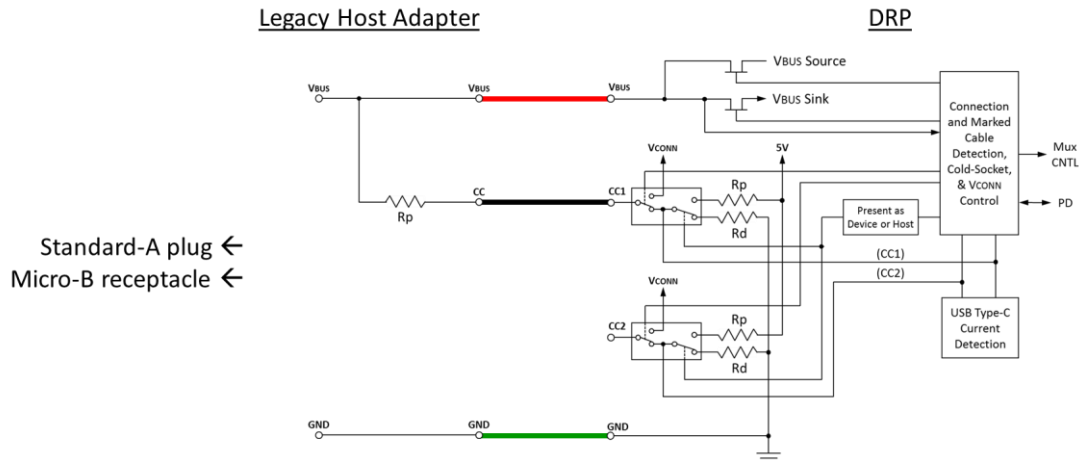

The following describes the behavior when a legacy host adapter that has an [Rp](#) to VBUS so as to mimic the behavior of a DFP is connected to a DRP. The value of [Rp](#) shall indicate an advertisement of Default USB Power (See Table 4-10).

1. DRP in the unattached state
 - DRP alternates between [Unattached.DFP](#) and [Unattached.UFP](#)
2. DRP transitions from [Unattached.UFP](#) to [Attached.UFP](#)
 - DRP in [Unattached.UFP](#) detects VBUS and enters [Attached.UFP](#)
 - DRP in [Unattached.UFP](#) may support [Try.DFP](#) and if so, may transition through [Try.DFP](#) and [Lock.UFP](#) prior to entering [Attached.UFP](#)
3. While the DRP is in the attached state:
 - DRP monitors VBUS for detach and when detected, enters [Unattached.UFP](#) (and resumes toggling between [Unattached.UFP](#) and [Unattached.DFP](#))

USB Type-C-based products that support [USB PD](#) BFSK are responsible for protecting the CC inputs from voltages greater than 5 V – see Section 4.6.2.4.

4.6 Power

Power delivery over the USB Type-C connector takes advantage of the existing USB methods as defined by: the [USB 2.0](#) and [USB 3.1](#) specifications, the [USB BC 1.2](#) specification and the [USB Power Delivery](#) specification. The USB Type-C Current mechanism allows the DFP to offer more current than defined by the [USB BC 1.2](#) specification.

All USB Type-C-based devices shall support USB Type-C Current and may support other USB-defined methods for power. The following order of precedence of power negotiation shall be followed: [USB BC 1.2](#) supersedes the [USB 2.0](#) and [USB 3.1](#) specifications, USB Type-C

Current at 1.5 A and 3.0 A supersedes [USB BC 1.2](#), and [USB Power Delivery](#) supersedes USB Type-C Current. Table 4-9 summarizes this order of precedence of power source usage.

Table 4-9 Precedence of power source usage

Precedence	Mode of Operation	Nominal Voltage	Maximum Current
Highest ↓ Lowest	USB PD	Configurable	5 A
	USB Type-C Current @ 3.0 A	5 V	3.0 A
	USB Type-C Current @ 1.5 A	5 V	1.5 A
	USB BC 1.2	5 V	Up to 1.5 A
	Default USB Power	USB 3.1	5 V
USB 2.0		5 V	500 mA

For example, once the PD mode (e.g. a power contract has been negotiated) has been entered, the device shall abide by that power contract ignoring any other previously made or offered by the USB Type-C Current, [USB BC 1.2](#) or [USB 2.0](#) and [USB 3.1](#) specifications. When the PD mode is exited, the device shall fallback in order to the USB Type-C Current, [USB BC 1.2](#) or [USB 2.0](#) and [USB 3.1](#) specification power levels.

All USB Type-C ports shall tolerate being connected to USB power source supplying default USB power, e.g. a host being connected to a legacy USB charger that always supplies VBUS.

4.6.1 Power Requirements during USB Suspend

USB Type-C implementations with [USB Type-C Current](#), [USB PD](#) and VCONN, along with active cables, requires the need to expand the traditional USB suspend definition.

4.6.1.1 VBUS Requirements during USB Suspend

The [USB 2.0](#) and [USB 3.1](#) specifications define the amount of current a UFP is allowed to consume during suspend.

USB suspend power rules shall apply when the [USB Type-C Current](#) is at the Default USB Power level or when [USB PD](#) is being used and the Suspend bit is set appropriately.

When [USB Type-C Current](#) is set at 1.5 A or 3.0 A, the UFP is allowed to continue to draw current from VBUS during USB suspend. During USB suspend, the UFP's requirement to track and meet the [USB Type-C Current](#) advertisement remains in force (See Section 4.5.2.3).

[USB PD](#) provides a method for the source to communicate to the sink whether or not the sink has to follow the USB power rules for suspend.

4.6.1.2 VCONN Requirements during USB Suspend

If the DFP supplies VBUS power during USB suspend, it shall also supply at least 7.5 mA to VCONN.

Electronically marked cables shall draw no more than 7.5 mA from VCONN during USB suspend.

4.6.2 VBUS Power Provided Over a USB Type-C Cable

The minimum requirement for VBUS power supplied over the USB Type-C cable matches the existing requirement for VBUS supplied over existing legacy USB cables. [USB Power Delivery](#) is an optional capability that is intended to work over un-modified USB Type-C to USB Type-C cables, therefore any USB Type-C cable assembly that incorporates electronics that gets its power from VBUS shall be tolerant up to 20 V.

4.6.2.1 USB Type-C Current

Default USB voltage and current are defined by the [USB 2.0](#) and [USB 3.1](#) specifications. All USB Type-C current advertisements are at the USB VBUS voltage defined by these specifications.

The USB Type-C Current feature provides the following extensions:

- Higher current than defined by the [USB 2.0](#), the [USB 3.1](#) or the [BC 1.2](#) specifications
- Allows the power source to manage the current it provides

The USB Type-C connector uses CC pins for configuration including an ability for a DFP to advertise to its port partner (UFP) the amount of current it can supply:

- Default values defined by the USB Specification
- 1.5 A
- 3.0 A

A UFP that takes advantage of the additional current offered (e.g., 1.5 A or 3.0 A) shall monitor the CC pins and shall adjust its current consumption within [tSinkAdj](#) to remain within the value advertised by the DFP. While a [USB PD](#) contract is in place, a UFP is not required to monitor USB Type-C current advertisements and shall not respond to USB Type-C current advertisements.

The DFP shall source VBUS to the UFP within [tVBUSON](#). VBUS shall be in the specified voltage range at the advertised current.

A port sourcing VBUS shall protect itself from a sink that draws current in excess of the port's USB Type-C Current advertisement.

The DFP adjusts [Rp](#) (or current source) to advertise which of the three current levels it supports. See Table 4-10 for the termination requirements for the DFP to advertise currents.

The value of [Rp](#) establishes a voltage ([vRd](#)) on CC that is used by the UFP to determine the maximum current it may draw.

Table 4-21 defines the CC voltage range observed by the UFP that only support default USB current.

If the UFP wants to consume more than the default USB current, it shall track [vRd](#) to determine the maximum current it may draw. See Table 4-22.

Figure 4-29 and Figure 4-30 illustrate where the UFP monitors CC for [vRd](#) to detect if the host advertises more than the default USB current.

Figure 4-29 UFP Monitoring for Current in Pull-Up/Pull-Down CC Model

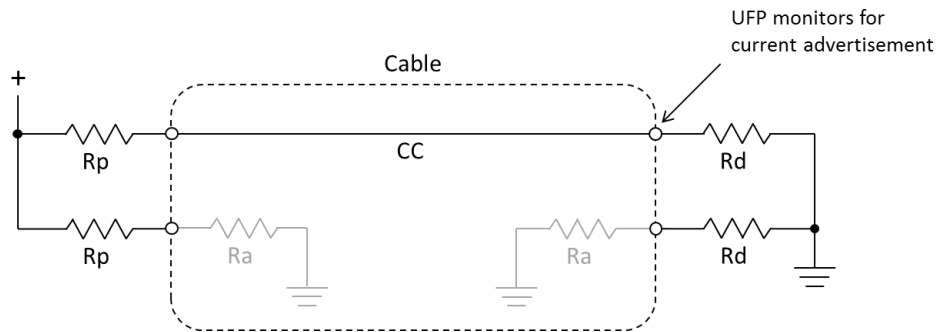
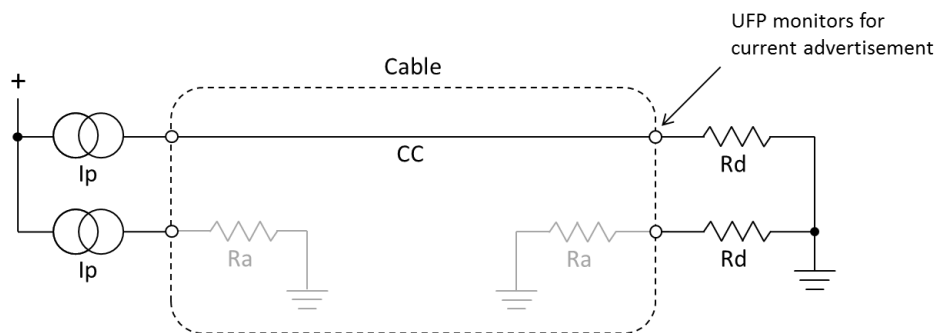

Figure 4-30 UFP Monitoring for Current in Current Source/Pull-Down CC Model



4.6.2.2 USB Battery Charging 1.2

[USB Battery Charging Specification, Revision 1.2](#) defines a method that uses the USB 2.0 D+ and D- pins to advertise VBUS can supply up to 1.5 A. Support for [USB BC 1.2](#) charging is optional.

USB Type-C-based [BC 1.2](#) chargers that are capable of supplying at least 1.5 A shall advertise [USB Type-C Current](#) at the 1.5 A level, otherwise the charger shall advertise [USB Type-C Current](#) at the Default USB Power level. A USB Type-C-based [BC 1.2](#) charger that also supports [USB Type-C Current](#) at 3.0 A may advertise [USB Type-C Current](#) at 3.0 A.

4.6.2.3 Proprietary Power Source

A proprietary power source (i.e., battery charger) with a USB Type-C-captive cable or a USB Type-C receptacle that is capable of supplying at least 1.5 A and less than 3.0 A shall advertise [USB Type-C Current](#) at least at the 1.5 A level.

A proprietary power source with a USB Type-C-captive cable or a USB Type-C receptacle that is capable of supplying at least 3.0 A shall advertise [USB Type-C Current](#) at least at the 3.0 A level.

4.6.2.4 USB Power Delivery

[USB Power Delivery](#) is a feature on the USB Type-C connector. When [USB PD](#) is implemented, [USB PD](#) Bi-phase Mark Coded (BMC) carried on the CC wire shall be used for [USB PD](#) communications between USB Type-C ports.

At attach, VBUS shall be operationally stable prior to initiating [USB PD](#) communications.

Figure 4-31 illustrates how the [USB PD](#) BMC signaling is carried over the USB Type-C cable's CC wire.

Figure 4-31 USB PD over CC Pins

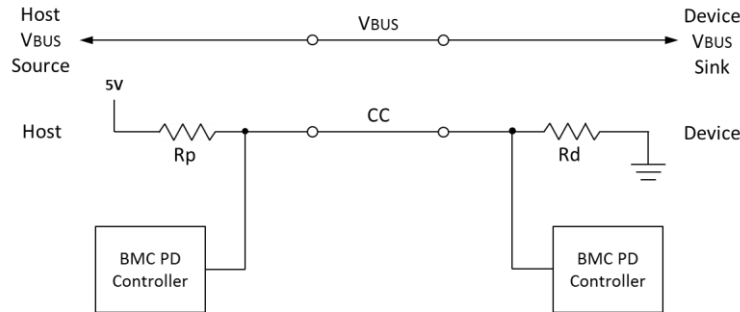
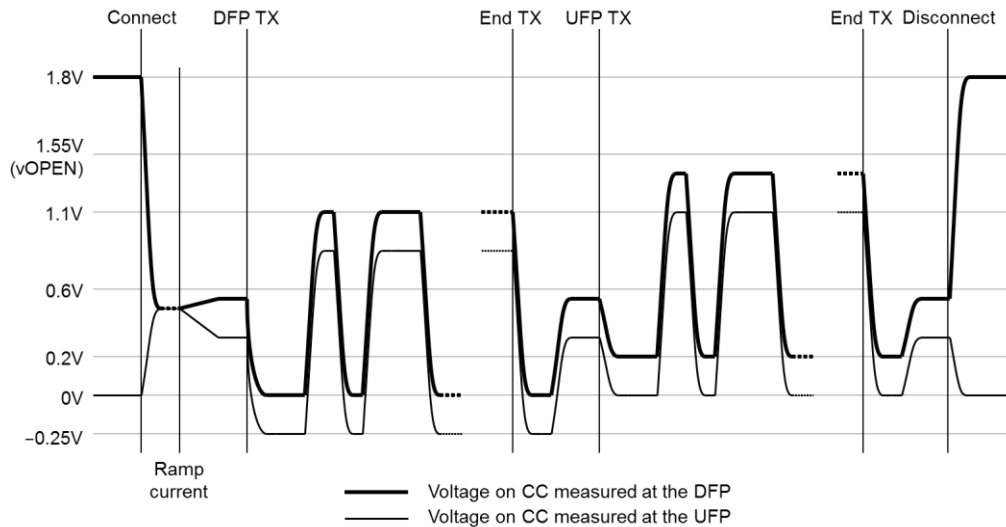

Figure 4-32 illustrates [USB PD](#) BMC signaling as seen on CC from both the perspective of the DFP and UFP. The breaks in the signaling are intended to represent the passage of time.

Figure 4-32 USB PD BMC Signaling over CC



While a [USB PD](#) contract is in place, the provider shall advertise a [USB Type-C Current](#) of either 1.5 A or 3.0 A.

4.6.3 Supporting USB PD BFSK in Addition to USB PD BMC

For USB Type-C to legacy cables and adapters, two situations exist where [USB PD](#) BFSK may be used to negotiate greater than 5 V: USB Type-C to USB Standard-A PD cable and USB Type-C to USB Micro-B receptacle adapter. In both of these cases, [Rp](#) may be pulled up to a value higher than 5 V because VBUS may range up to 20 V for a [USB PD](#) negotiated contract. USB Type-C-based products that support [USB PD](#) BFSK and request a voltage greater than 5 V shall protect the CC inputs from termination voltages higher than 5 V as some adapters may present an [Rp](#) pulled up to VBUS that may be as high as 20 V.

Figure 4-33 illustrates an example of protecting the CC input from a higher voltage and does so in a manner that does not interfere with [USB PD](#) BMC communication.

Figure 4-33 Example implementation of CC input protection in a UFP

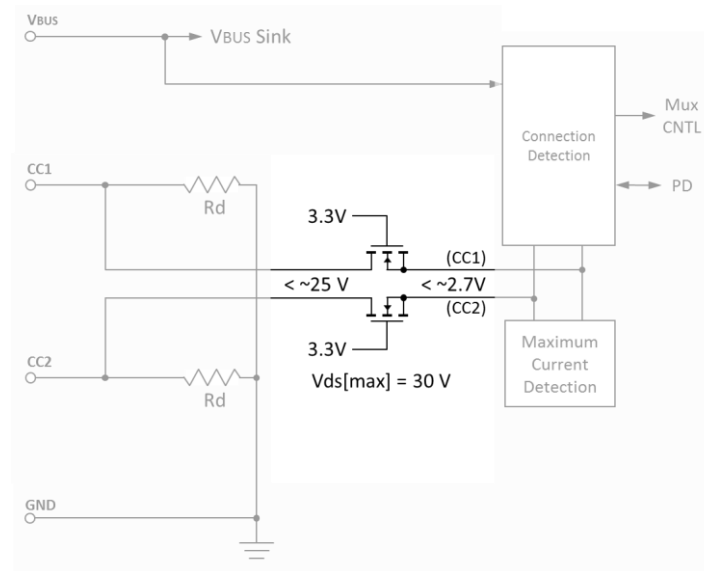

The [USB PD](#) Binary Frequency Shift Keying (BFSK) on VBUS may in addition be used to communicate with legacy [USB PD](#) products. [USB PD](#) BFSK shall only be used if [USB PD](#) BMC fails to establish PD communication, i.e. fails to receive a [USB PD](#) GoodCRC message in response to a [USB PD](#) Capabilities message following two hard resets. USB Type-C-based UFPs that support [USB PD](#) BFSK and want to request more than 1.5 A shall supply VCONN and confirm that the cable is [electronically marked](#) and capable of the desired current level (see Section 5.2.2).

4.7 USB Hubs

USB hubs are defined by the [USB 2.0](#) and [USB 3.1](#) specifications. USB hubs implemented with one or more USB Type-C connectors shall comply with the [USB 3.1 Specification](#).

USB hubs shall have one UFP that may be a Charging UFP (See Section 4.8.3). The hub shall clearly identify to the user its UFP. This may be accomplished by physical isolation, labeling or a combination of both.

USB hub's DFPs shall not have DRP capability.

CC pins are used for port-to-port connections and shall be supported on all USB Type-C connections on the hub.

USB hub ports shall not implement or pass-through Alternate or Accessory Modes. SBU pins shall not be connected ([zSBU Termination](#)) on any USB hub port.

The USB hub's DFPs shall support power source requirements for a DFP. See Section 4.8.1.

4.8 Chargers

4.8.1 DFP as a Power Source

DFPs (e.g. battery chargers, hub DFPs and hosts) may all be used for battery charging. When a charger with a USB Type-C receptacle or a USB Type-C captive cable, it shall follow all the applicable requirements.

- A DFP shall expose its power capabilities using the [USB Type-C Current](#) method and it may additionally support other USB-standard methods ([USB BC 1.2](#) or [USB-PD](#)).
- A DFP may also expose its identity and/or power capabilities using a proprietary (e.g. non-USB-standard) method. A proprietary method may source up to 5 A if it has a captive cable capable of carrying that level of current. See Section 4.6.2.3 for additional requirements.
- A USB Type-C power provider advertising its current capability using [USB BC 1.2](#) shall meet the requirements in Section 4.6.2.2 regarding USB Type-C Current advertisement.
- A USB Type-C power provider that has negotiated a [USB-PD](#) contract shall meet the requirements in Section 4.6.2.4 regarding [USB Type-C Current](#) advertisement.
- If a USB Type-C power provider is capable of supplying a voltage greater than default VBUS, it shall fully conform to the [USB-PD](#) specification, and shall negotiate its power contracts using only [USB-PD](#).
- If a USB Type-C power provider is capable of reversing source and sink power roles, it shall fully conform to the [USB-PD](#) specification, and shall negotiate its power contracts using only [USB-PD](#).
- If a USB Type-C power provider is capable of supplying a current greater than 3.0 A, it shall use the [USB-PD](#) Discovery Identity to determine the current carrying capacity of the cable.

4.8.1.1 Chargers with USB Type-C Receptacles

- A charger with a USB Type-C receptacle (DFP) shall only apply power to VBUS when it detects a UFP is attached and shall remove power from VBUS when it detects the UFP is detached ([vOPEN](#)).
- A charger with a USB Type-C receptacle shall not advertise current exceeding 3.0 A except when it uses the [USB-PD](#) Discover Identity mechanism to determine the cable's actual current carrying capability and then it shall limit the advertised current accordingly.

4.8.1.2 Chargers with USB Type-C Captive Cables

- A charger with a USB Type-C captive cable may supply VBUS at any time. It is recommended that such a charger only apply power to VBUS when it detects a UFP is present and remove power from VBUS when it detects the UFP is not present ([vOPEN](#)).
- A charger with a USB Type-C captive cable shall limit its current advertisement so as not to exceed the current capability of the cable (up to 5 A).

4.8.2 Non-USB Charging Methods

A charger with a USB Type-C connector may employ additional proprietary charging methods to source power beyond what is allowed by the USB defined methods. When implemented, proprietary methods must meet the following requirements:

- The method shall only be used to establish identity and/or a current level at default VBUS voltage in a manner not defined by the USB methods
- The method shall only define the current level and shall not change the voltage delivered on VBUS
- The method shall not alter the DFP's role to source VBUS or the UFP's role to sink VBUS

- See Section 4.6.2.3 for additional requirements regarding USB Type-C Current advertisement.

A product with a USB Type-C connector that sinks power may support proprietary charging methods, these products shall not support methods that redefine VBUS voltage beyond what is defined by the [USB 2.0](#) and [USB 3.1](#) specifications.

4.8.3 Charging UFP

A Charging UFP is a special sub-class of a DRP that is capable of supplying power, but not capable of acting as a host. For example a hub's UFP or a monitor's UFP that operates as a device but not as a host.

The Charging UFP shall follow the rules for a DRP (See Section 4.5.1.4 and Figure 4-15). It shall also follow the requirements for the DFP as Power Source (See Section 4.8.1). The Charging UFP shall support [USB PD](#) and shall support the DR_Swap command.

4.8.4 Charging a System with a Dead Battery

A system that supports being charged by USB whose battery is dead shall apply [Rd](#) to both CC1 and CC2 and follow all UFP rules. When it is connected to a DFP or Charging UFP, the system will receive the default VBUS. It may use any allowed method to increase the amount of power it can use to charge its battery.

Circuitry to present [Rd](#) in a dead battery case only needs to guarantee the voltage on CC is pulled within the same range as the voltage clamp implementation of [Rd](#) in order for a DFP to recognize the UFP and provide VBUS. For example, a 20% resistor of value [Rd](#) in series with a FET with $V_{GTH(max)} < V_{CLAMP(max)}$ with the gate weakly pulled to CC would guarantee detection and be removable upon power up.

When the system with a dead battery has sufficient charge, it may use the [USB PD](#) DR_Swap message to become the DFP.

4.9 Electronically Marked Cables

All USB Full-Featured Type-C cables shall be electronically marked. USB 2.0 Type-C cables may be electronically marked.

Electronically marked cables shall support [USB Power Delivery](#) Structured VDM Discover Identity command directed to SOP'. This provides a method to determine the characteristics of the cable, e.g. its current carrying capability, its performance, vendor identification, etc. This may be referred to as the USB Type-C Cable ID function.

Prior to an explicit [USB PD](#) contract, a Charging UFP is allowed to use SOP' to discover the cable's identity. After an explicit [USB PD](#) contract has been negotiated, only the DFP shall communicate with SOP'.

An electronically marked cable incorporates electronics that require VCONN, although VBUS or another source may be used. Electronically marked cables that do not incorporate data bus signal conditioning circuits shall consume no more than 70 mW from VCONN. During USB suspend, electronically marked cables shall not draw more than 7.5 mA from VCONN, see Section 4.6.1.2.

Figure 4-34 illustrates a typical electronically marked cable. The isolation elements (Iso) shall prevent VCONN from traversing end-to-end through the cable. [Ra](#) is required in the cable to allow the DFP to determine that VCONN is needed.

Figure 4-34 Electronically Marked Cable with VCONN connected through the cable

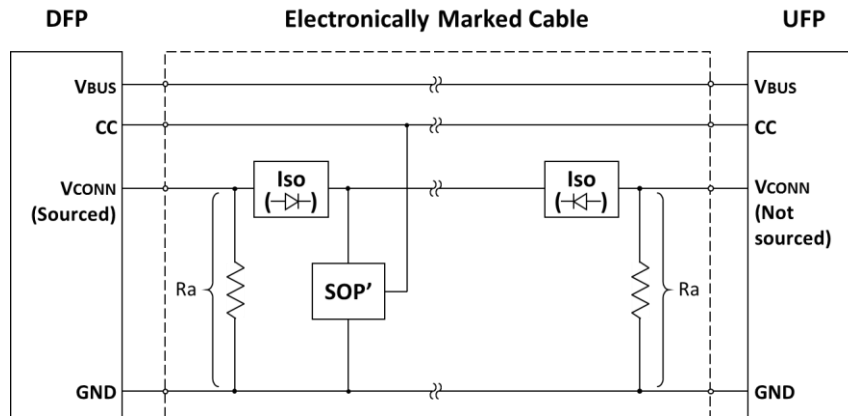
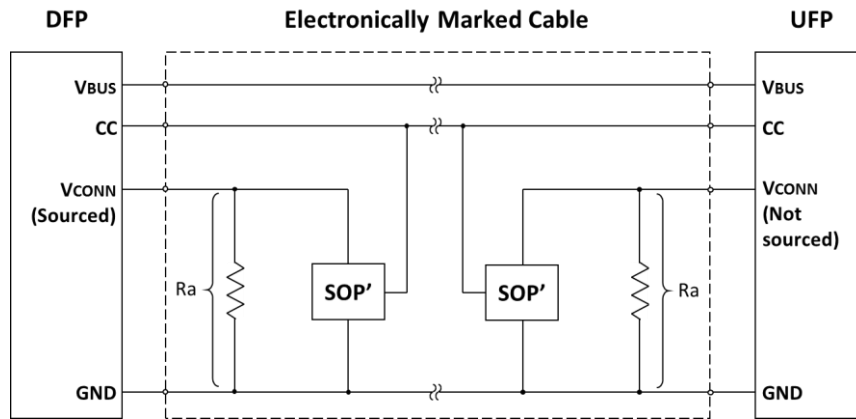

Figure 4-35 illustrates an electronically marked cable where the VCONN wire does not extend through the cable, therefore an SOP' element is required at each end of the cable. In this case, no isolation elements are needed.

Figure 4-35 Electronically Marked Cable with SOP' at both ends



For cables that only respond to SOP', the location of the responder is not relevant.

An active cable is an electronically marked cable that incorporates data bus signal conditioning circuits, for example to allow for implementing longer cables. Active cables shall not draw more than 1 W from VCONN, see Section 4.4.3.

Active cables may or may not require configuration management. Requirements for active cables that require configuration management are provided in Section 5.2.

Refer to Section 4.4.3 for the requirements of a DFP to supply VCONN. When VCONN is not present, a powered cable shall not interfere with normal CC operation including UFP detection, current advertisement and [USB PD](#) operation.

4.10 VCONN-Powered Accessories

A VCONN-powered accessory is a direct-attach UFP that implements an [Alternate Mode](#) (See Section 5.1) and can operate with just VCONN.

The VCONN-powered accessory exposes a maximum impedance to ground of [Ra](#) on the VCONN pin and [Rd](#) on the CC pin.

When operating in the UFP role and when VBUS is not present, VCONN-powered accessories shall treat the application of VCONN as an attach signal, and shall respond to [USB Power Delivery](#) messages.

When powered by only VCONN, a VCONN-powered accessory shall negotiate an [Alternate Mode](#). If it fails to negotiate an [Alternate Mode](#) within [tAMTimeout](#), its port partner removes VCONN.

VCONN-powered accessories shall be able to operate over a range of 2.7 V to 5.5 V on VCONN.

The removal of VCONN when VBUS is not present shall be treated as a detach event.

When VBUS is supplied, a VCONN-powered accessory is subject to all of the requirements for UFPs, including presenting a [USB Billboard Device Class](#) interface if negotiation for an Alternate Mode fails.

4.11 Parameter Values

4.11.1 Termination Parameters

Table 4-10 provides the values that shall be used for the DFP's [Rp](#) or current source. Other pull-up voltages shall be allowed if they remain less than 5.5 V and fall within the correct voltage ranges on the UFP side – see Table 4-18, Table 4-19 and Table 4-20. Note: when two DFPs are connected together, they may use different termination methods which could result in unexpected current flow.

Table 4-10 DFP CC Termination (Rp) Requirements

DFP Advertisement	Current Source to 1.7 – 5.5 V	Resistor pull-up to 4.75 – 5.5 V	Resistor pull-up to 3.3 V ± 5%
Default USB Power	80 µA ± 20%	56 kΩ ± 20%	36 kΩ ± 20%
1.5 A @ 5 V	180 µA ± 8%	22 kΩ ± 5%	12 kΩ ± 5%
3.0 A @ 5 V	330 µA ± 8%	10 kΩ ± 5%	4.7 kΩ ± 5%

The UFP may find it convenient to implement [Rd](#) in multiple ways simultaneously (a wide range [Rd](#) when unpowered and a trimmed [Rd](#) when powered). Transitions between [Rd](#) implementations that do not exceed [tCCDebounce](#) shall not be interpreted as exceeding the wider [Rd](#) range. Table 4-11 provides the methods and values that shall be used for the UFP's [Rd](#) implementation.

Table 4-11 UFP CC Termination (Rd) Requirements

Rd Implementation	Nominal value	Can detect power capability?	Max voltage on pin
± 20% voltage clamp¹	1.1 V	No	1.32 V
± 20% resistor to GND	5.1 kΩ	No	2.18 V
± 10% resistor to GND	5.1 kΩ	Yes	2.04 V

Note:

1. The clamp implementation inhibits [USB PD](#) communication although the system can start with the clamp and transition to the resistor once it is able to do [USB PD](#).

Table 4-12 provides the impedance value to ground on VCONN in powered cables.

Table 4-12 Powered cable Termination Requirements

	Minimum Impedance	Maximum Impedance
Ra	800 Ω ¹	1.2 kΩ

Note:

1. The minimum impedance may be less when powering active circuitry.

Table 4-13 provides the minimum impedance value to ground on CC for a self-powered device (UFP) to be undetected by a DFP.

Table 4-13 UFP CC Termination Requirements

	Minimum Impedance to GND
zOPEN	126 kΩ

Table 4-14 provides the impedance value for an SBU to appear open.

Table 4-14 SBU Termination Requirements

	Termination	Notes
zSBUTermination	≥ 950 kΩ	Functional equivalent to an open circuit

4.11.2 Timing Parameters

Table 4-15 provides the timing values that shall be met for delivering power over VBUS and VCONN.

Table 4-15 VBUS and VCONN Timing Parameters

	Minimum	Maximum	Description
tVBUSON	0 ms	275 ms	From the time the UFP is attached until the DFP supplies VBUS.
tVBUSOFF	0 ms	650 ms	From the time the UFP is detached until the DFP removes VBUS and reaches vSafe0V (See USB PD). Note: In the case where the UFP is sourcing VBUS, e.g. USB PD PR_Swap, the UFP monitors vRd to detect detach.
tVCONNON	0 ms	10 ms	From the time the DFP supplied VBUS in either the Attach.DFP.DRPWait or Attached.DFP states.
tVCONNON-PA	0 ms	100 ms	From the time a UFP with accessory support enters the Powered.Accessory state until the UFP sources VCONN.
tVCONNOFF	0 ms	35 ms	From the time that a UFP is detached or as directed until the VCONN supply is disconnected and bulk capacitance is removed.
tSinkAdj	tPDDebounce	60 ms	Response time for a UFP to adjust its current consumption to be in the specified range due to a change in USB Type-C Current advertisement

Figure 4-36 illustrates the timing parameters associated with the DRP toggling process. The [tDRP](#) parameter represents the overall period for a single cycle during which the port is exposed as both a DFP and a UFP. The portion of the period where the DRP is exposed as a DFP is established by [dcDFP.DRP](#) and the maximum transition time between the exposed states is dictated by [tDRPTransition](#).

Figure 4-36 DRP Timing

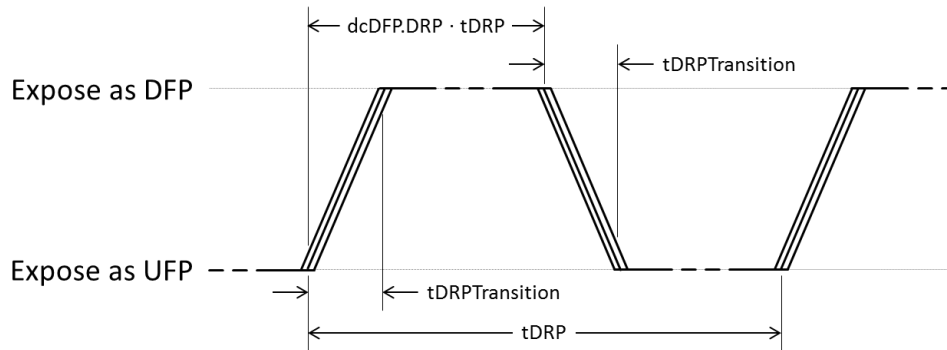

Table 4-16 provides the timing values that shall be met for DRPs. The clock used to control DRP swap should not be derived from a precision timing source such as a crystal, ceramic resonator, etc. to help minimize the probability of two DRP devices indefinitely failing to resolve into a DFP to UFP relationship. Similarly, the percentage of time that a DRP spends advertising DFP not be derived from a precision timing source.

Table 4-16 DRP Timing Parameters

	Minimum	Maximum	Description
tDRP	50 ms	100 ms	The period a DRP shall complete a DFP to UFP and back advertisement
dcDFP.DRP	30%	70%	The percent of time that a DRP shall advertise DFP during tDRP
tDRPTransition	0 ms	1 ms	The time a DRP shall complete transitions between DFP and UFP roles during role resolution
tDRPHold	100 ms	150 ms	Wait time associated with the Attach.DFP.DRPWait state
tDRPLock	100 ms	150 ms	Wait time associated with the Lock.UFP state
tDRPTry	400 ms	450 ms	Wait time associated with the Try.DFP

Table 4-17 provides the timing requirement for CC connection behaviors.

Table 4-17 CC Timing

	Minimum	Maximum	Description
tCCDebounce	2 ms	15 ms	Time a port shall wait before it can determine it is attached
tPDDebounce	10 ms	20 ms	Time a port shall wait before it can determine it is either detached or a change in USB Type-C current due to the potential for USB PD BMC signaling on CC
tAccDetect	50 ms	200 ms	Time before Accessory Mode shall be entered
tErrorRecovery	25 ms		Time a port shall remain in the ErrorRecovery state.

4.11.3 Voltage Parameters

Table 4-18, Table 4-19 and Table 4-20 provide the CC voltage values that a DFP shall use to detect what is attached based on the [USB Type-C Current](#) advertisement (Default USB, 1.5 A @ 5 V, or 3.0 A @ 5 V) that the DFP is offering.

Table 4-18 CC Voltages on DFP Side - Default USB

	Minimum Voltage	Maximum Voltage	Threshold
Powered cable/adaptor (vRa)	0.00 V	0.15 V	0.20 V
UFP (vRd)	0.25 V	1.50 V	1.60 V
No connect (vOPEN)	1.65 V		

Table 4-19 CC Voltages on DFP Side - 1.5 A @ 5 V

	Minimum Voltage	Maximum Voltage	Threshold
Powered cable/adaptor (vRa)	0.00 V	0.35 V	0.40 V
UFP (vRd)	0.45 V	1.50 V	1.60 V
No connect (vOPEN)	1.65 V		

Table 4-20 CC Voltages on DFP Side - 3.0 A @ 5 V

	Minimum Voltage	Maximum Voltage	Threshold
Powered cable/adaptor (vRa)	0.00 V	0.75 V	0.80 V
UFP (vRd)	0.85 V	2.45 V	2.60 V
No connect (vOPEN)	2.75 V		

Table 4-21 provides the CC voltage values that shall be detected across a UFP's [Rd](#) for a UFP that does not support higher than default [USB Type-C Current](#) DFP advertisements.

Table 4-21 Voltage on UFP CC Pins (Default USB Type-C Current only)

Detection	Min voltage	Max voltage	Threshold
vRa	-0.25 V	0.15 V	0.2 V
vRd-Connect	0.25 V	2.18 V	

Table 4-22 provides the CC voltage values that shall be detected across a UFP's [Rd](#) for a UFP that implements detection of higher than default [USB Type-C Current](#) DFP advertisements. This table includes consideration for the effect that the IR drop across the cable GND has on the voltage across the UFP's [Rd](#).

Table 4-22 Voltage on UFP CC pins (Multiple DFP Current Advertisements)

Detection	Min voltage	Max voltage	Threshold
vRa	-0.25 V	0.15 V	0.2 V
vRd-Connect	0.25 V	2.04 V	
vRd-USB	0.25 V	0.61 V	0.66 V
vRd-1.5	0.70 V	1.16 V	1.23 V
vRd-3.0	1.31 V	2.04 V	

4.12 Summary of Ports by Product Type

The USB Type-C ports can exist in any one of 16 possible states. These states are characterized by:

- DFP (host-mode) or UFP (device-mode)
- Sourcing ([Rp](#)) or sinking ([Rd](#)) VBUS
- Data capable or not
- Sourcing VCONN

Table 4-23 summarizes all of the port states as differentiated by these four characteristics. This informative table may be helpful in understanding where a port starts (as indicated by bold ✓ marks) and the states the port traverses to get to an end condition for a particular type of host, hub or device.

It should be noted that some products are shown to have multiple possible starting states, these port types include DRPs, DFPs that default to UFPs in dead battery conditions, or UFPs that support upstream charging of dead battery hosts.

If applicable, the two primary [USB PD](#)-based swapping mechanisms are listed in the table for each product port types:

- Power Swap (PS) using [USB PD](#) PR_Swap : swaps VBUS source ([Rp](#)) and sink ([Rd](#))
- Data Swap (DS) using [USB PD](#) DR_Swap : swaps DFP (host-mode) and UFP (device-mode) roles

For product port types that support [USB PD](#), a third [USB PD](#)-based swapping mechanism may be supported:

- VCONN Swap using [USB PD](#) VCONN_Swap : swaps which end sources of VCONN

Subscripts highlight which of these three swapping mechanisms may be used in the transition from one port state to another. For example, for a Host DFP that supports PR_Swap under normal conditions, the initial port state would be 1 (DFP, Source, Yes, On) but would transition to 2 (DFP, Sink, Yes, On) with a [USB-PD](#) PR_Swap. For a DRP-based product, port transitions are dependent on the order that swaps are applied from the initial port state.

Table 4-23 Summary of Ports and Behaviors by Product Type

	DFP/UFP		DFP		DFP		DFP		DFP		DFP		DFP		DFP		DFP		DFP		UFP		UFP	
	Source	Sink	Source	Sink	Source	Sink	Source	Sink	Source	Sink	Source	Sink	Source	Sink	Source	Sink	Source	Sink	Source	Sink	Source	Sink	Source	Sink
VBUS	Yes	No	Yes	No	Yes	No	Yes	No	Yes	No	Yes	No	Yes	No	Yes	No	Yes	No	Yes	No	Yes	No	Yes	No
Data	Yes	No	Yes	No	Yes	No	Yes	No	Yes	No	Yes	No	Yes	No	Yes	No	Yes	No	Yes	No	Yes	No	Yes	No
VCONN	On	On	On	On	Off	Off	Off	Off	Off	Off	Off	Off	Off	Off	Off	Off	Off	Off	Off	Off	Off	Off	Off	Off
	1	2	3	4	5	6	7	8	9	10	11	12	13	14	15	16								
Host	DFP	✓			✓																			
	DFP with PS	✓	✓1		✓	✓1,3																		✓4
Host/ Device	DRP	✓			✓																	✓		
	DRP with PS	✓	✓1		✓	✓1,3			✓1,3				✓1	✓								✓		✓4
	DRP with DS	✓			✓				✓2,3				✓2	✓								✓		
	DRP with PS/DS	✓	✓1			✓	✓1,3		✓1,2,3				✓1,2	✓								✓		✓4
Device	UFP									✓3				✓								✓		
	UFP with PS								✓1,3	✓3			✓1	✓								✓		
Hub Hub (UFP)	Hub UFP									✓3				✓								✓		
	Charging UFP			✓4			✓4		✓1,3	✓3		✓1	✓									✓		
Hub Hub (DFP)	Hub DFP	✓			✓																			
	DFP with PS	✓	✓1		✓	✓1,3																		
Power supply/Charger			✓																					
Power sucking device																								✓

Notes: 1 = PR_Swap (PS) used; 2 = DR_Swap (DS) used; 3 = VCONN_Swap used; 4 = Dead battery state/support

5 Functional Extensions

5.1 Alternate Modes

All hosts and devices (except chargers) using a USB Type-C receptacle shall expose a USB interface. In the case where the host or device optionally supports Alternate Modes:

- The host and device shall use [USB Power Delivery](#) Structured Vendor Defined Messages (Structured VDMs) to discover, configure and enter/exit modes to enable Alternate Modes
- The device is strongly encouraged to provide equivalent USB functionality where such exists for best user experience
- Where no equivalent USB functionality is implemented, the device shall provide a USB interface exposing a [USB Billboard Device Class](#) used to provide information needed to identify the device

As Alternate Modes do not traverse the USB hub topology, they shall only be used between a directly connected host and device.

5.1.1 Alternate Mode Architecture

The [USB Power Delivery](#) Structured VDMs are defined to extend the functionality a device exposes. Only Structured VDMs shall be used to alter the USB functionality or reconfigure the pins the USB Type-C Connector exposes. Structured VDMs provide a standard method to identify the modes a device supports and to command the device to enter and exit a mode. The use of Structured VDMs are in addition to the normal [USB PD](#) messages used to manage power. Structured VDMs may be interspersed within the normal [USB PD](#) messaging stream, however they may not be inserted in the middle of an ongoing PD power negotiation.

The Structured VDMs consist of a request followed by a response. The response is either a successful completion of the request (ACK), an indication that the device needs time before it can service a request (BUSY), or a rejection of the request (NAK). A host and device do not enter a mode when either a NAK or BUSY is returned.

Multiple modes may exist and/or function concurrently. For example, a Structured VDM may be used to manage an active cable at the same time that another Structured VDM is used to manage the device so that both the cable and device are operating in a compatible mode.

5.1.2 Alternate Mode Requirements

The host and device shall negotiate a [USB PD](#) Explicit Contract before Structured VDMs may be used to discover or enter an Alternate Mode.

The ACK shall be sent after switching to the Alternate Mode has been completed by the UFP for Enter Mode and Exit Mode requests. See Section 6.4.4 in the [USB Power Delivery Specification](#).

If a device fails to successfully enter an Alternate Mode within [tAMTimeout](#) then the device shall minimally expose a [USB 2.0](#) interface ([USB Billboard Device Class](#)) that is powered by VBUS.

When a device offers multiple modes, especially where multiple Alternate Mode definitions are needed in order to be compatible with multiple host-side implementations, successfully entering an Alternate Mode may be predicated on only one of the available modes being successfully recognized by a host. In this case, the device is not required to expose but may still expose a [USB Billboard Device Class](#) interface to indicate to the host the availability and status of the modes it supports.

The host may send an Enter Mode after [tAMETimeout](#). If the device enters the mode, it shall respond with an ACK and discontinue exposing the [USB Billboard Device Class](#) interface. The device may expose the [USB Billboard Device Class](#) interface again with updated capabilities.

The current supplied over VCONN may be redefined by a specific Alternate Mode but the power shall not exceed the current rating of the pin (See Section 3.7.7.4).

5.1.2.1 Alternate Mode Pin Reassignment

Figure 5-1 illustrates the only pins that shall be available for functional reconfiguration in a full-featured cable. The pins highlighted in yellow are the only pins that shall be reconfigured.

Figure 5-1 Pins Available for Reconfiguration over the Full-Featured Cable

A12	A11	A10	A9	A8	A7	A6	A5	A4	A3	A2	A1
GND	RX2+	RX2-	VBUS	SBU1	D-	D+	CC	VBUS	TX1-	TX1+	GND
GND	TX2+	TX2-	VBUS	VCONN			SBU2	VBUS	RX1-	RX1+	GND
B1	B2	B3	B4	B5	B6	B7	B8	B9	B10	B11	B12

Figure 5-2 illustrates the only pins that shall be available for functional reconfiguration in direct connect applications such as a cradle dock, captive cable or a detachable notebook. The pins highlighted in yellow are the only pins that shall be reconfigured. Three additional pins are available because this configuration is not limited by the cable wiring.

Figure 5-2 Pins Available for Reconfiguration for Direct Connect Applications

A12	A11	A10	A9	A8	A7	A6	A5	A4	A3	A2	A1
GND	RX2+	RX2-	VBUS	SBU1	D-	D+	CC	VBUS	TX1-	TX1+	GND
GND	TX2+	TX2-	VBUS	VCONN			SBU2	VBUS	RX1-	RX1+	GND
B1	B2	B3	B4	B5	B6	B7	B8	B9	B10	B11	B12

5.1.2.2 Alternate Mode Electrical Requirements

Signaling during the use of Alternate Modes shall comply with all relevant cable assembly, adapter assembly and electrical requirements of Chapter 3.

Two requirements are specified in order to minimize risk of damage to the USB SuperSpeed transmitters and receivers in a USB host or device:

- When operating in an Alternate Mode and pin pairs A2, A3 (TX1) and B2, B3 (TX2) are used, these shall be AC coupled in or before the plug.
- Alternate Mode signals being received at the USB Type-C receptacle shall not exceed the value specified for VTX-DIFF-PP in Table 6-17 of the [USB 3.1](#) specification.

When in an Alternate Mode, activity on the SBU lines shall not interfere with [USB PD](#) BMC communications or interfere with detach detection.

The USB Safe State is defined by the [USB PD](#) specification. The USB Safe State defines an electrical state for the SBU1/2 and SSTX/SSRX for DFPs, UFPs, and Active Cables when transitioning between USB and an Alternate Mode. SBU1/2 and SSTX/SSRX must transition

to the USB Safe State before entering to or exiting from an Alternate Mode. Table 5-1 defines the electrical requirements for the USB Safe State. See the USB-PD Specification for more detail on entry/exit mechanisms to the USB Safe State.

Table 5-1 USB Safe State Electrical Requirements

	SBU1/2	SSTX^{1,2}	SSRX²	B6/B7⁴
Common-mode voltage	0 to 1.5 V	0 to 1.5 V	0 to 1.5 V	0 to 1.5 V
Impedance to ground³	< 4 MΩ	< 4 MΩ	25 KΩ – 4 MΩ	< 4 MΩ

Notes:

1. SSTX common-mode voltage is defined on the integrated circuit side of the AC coupling capacitors.
2. Unused SSTX and SSRX signals should transition to USB Safe State if wired to the connector but not used.
3. The DFP and UFP shall provide a discharge path to ground in USB Safe State when a connection to the USB Type-C receptacle is present.
4. Applies to docking solutions that redefine pins B6 and B7.

5.1.3 Parameter Values

Table 5-2 provides the timeout requirement for a device that supports Alternate Modes to enable a [USB Billboard Device Class](#) interface when none of the modes supported by the device are successfully recognized and configured by the DFP to which the device is attached.

Table 5-2 USB Billboard Device Class Availability Following Alternate Mode Entry Failure

	Maximum	Description
tAMETimeout	1000 ms	The time between a UFP attach until a USB Billboard Device Class interface is exposed when an Alternate Mode is not successfully entered

While operating in an Alternate Mode, the signaling shall not cause noise ingress on to USB signals operating concurrently that exceeds the Vnoise parameters given in Table 5-3.

Table 5-3 Alternate Mode Signal Noise Ingression Requirements

	Limit	Bandwidth
Vnoise on BMC	10 mV	100 ns time constant filter
Vnoise on D+/D- (Single-ended)	40 mV	500 MHz
Vnoise on D+/D- (Differential)	10 mV	500 MHz

Note: Each Vnoise parameter is the max noise ingress level allowed onto the respective interface that is due to all aggressors from the Alternate Mode signaling, under respective worst case scenarios. Aggressors include Alternate Mode interface signals on the SBU wires that couple within USB Type-C cable to the respective victim interface, according to USB Type C cable specification Section 3.7.3.3.

5.1.4 Example Alternate Mode – USB/PCIe Dock

This example illustrates the use of Structured VDMs to expose and access functionality beyond the basic functionality defined by the USB Type-C Connector. The device uses its USB Type-C connector to make connection when placed in a cradle dock. This example only illustrates the functional connections.

5.1.4.1 USB/PCIe Dock Example

- The cradle dock provides mechanical alignment and attachment in addition to those provided by the USB Type C connector and allows for only one orientation.
- The dock uses [USB PD](#) to manage charge/power to the Device.
- The dock uses PCIe to connect additional dock functions, e.g. a network controller.
- The dock has a USB hub that exposes three external USB ports and attached internal USB Devices, e.g. a USB audio Device (a 3.5 mm audio jack).

Figure 5-3 illustrates the USB/PCIe dock example in a block diagram form.

Figure 5-3 USB/PCIe Dock Example

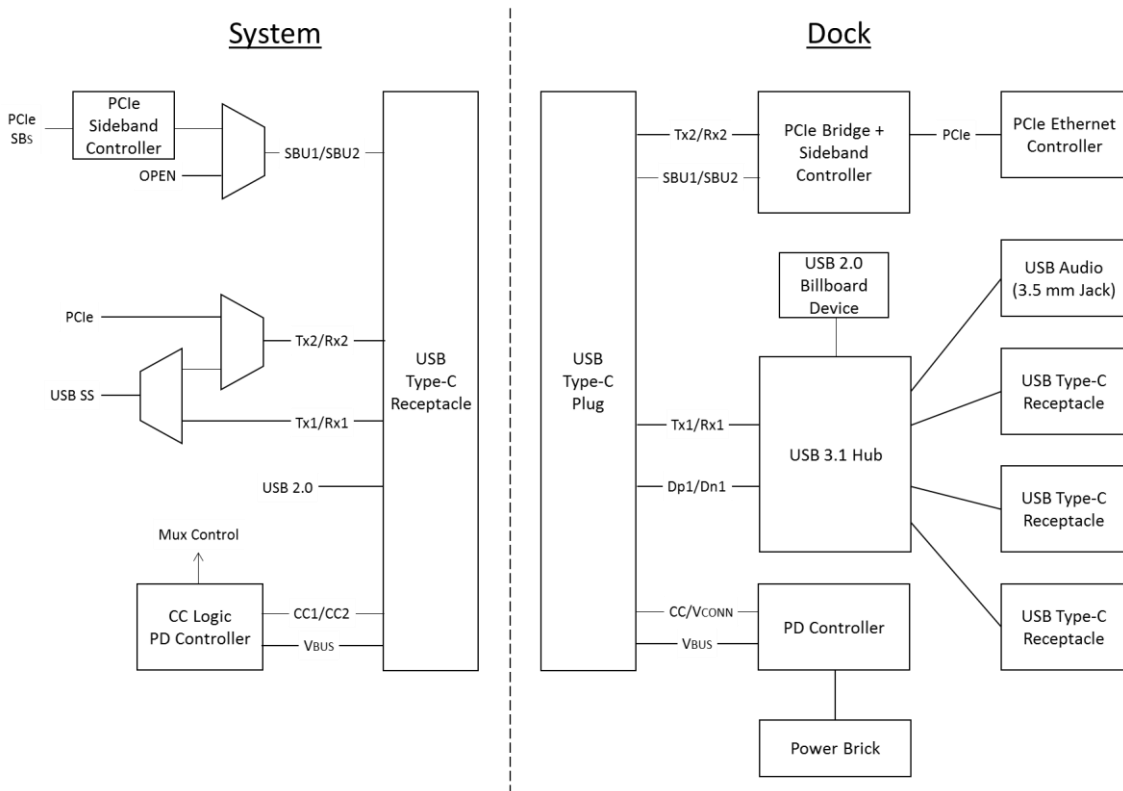

The system uses [USB PD](#) Structured VDMs to communicate with the dock to discover that it supports a compatible Alternate Mode. The system then uses a Structured VDM to enter the dock mode. Since [USB PD](#) is used, it may also be used to negotiate power for the system and dock. In this example, the USB SuperSpeed signals allow the dock to work as a USB-only dock with a system that does not fully support the dock or even [USB PD](#).

5.1.4.2 Functional Overview

The following summarizes the behavior resulting from attaching the example USB/PCIe Dock for three likely host system cases.

1. Host system does not support [USB PD](#) or supports [USB PD](#) without Structured VDMs
 - Since the Host does not support [USB PD](#), it will not look for SVIDs using the Structured VDM method.
 - The host discovers the USB hub and operates as it would when connected to any USB hub.
 - Since the host does not support [USB PD](#), after [tAMTimeout](#) the dock will expose a [USB Billboard Device Class](#) interface that the host will enumerate. The host then reports to the user that an unsupported Device has been connected, identifying the type of Device from the [USB Billboard Device Class](#) information.
2. Host system supports [USB PD](#) and Structured VDMs but does not support this specific USB/PCIe Dock
 - The host discovers the USB hub and operates as it would when connected to any USB hub.
 - The Host looks for SVIDs that it recognizes. The VID associated with this USB/PCIe Dock may or may not be recognized by the Host.
 - If that VID is recognized by the Host, the Host then requests the modes associated with this VID. The mode associated with this USB/PCIe Dock is not recognized by the Host.
 - Since the host does not recognize the mode as being supported, after [tAMTimeout](#) the dock will expose a [USB Billboard Device Class](#) interface that the host will enumerate. The host then reports to the user that an unsupported Device has been connected, identifying the type of Device from the [USB Billboard Device Class](#) information.
3. Host system supports this specific USB/PCIe Dock
 - The Host looks for SVIDs that it recognizes. The VID associated with this USB/PCIe Dock is recognized by the Host.
 - The Host then requests the modes associated with this VID. The mode associated with this USB/PCIe Dock is recognized by the Host.
 - Since this mode is recognized as supported, the Host uses the Enter Mode command to reconfigure the USB Type-C receptacle and enter the USB/PCIe Dock mode.
 - The device may expose the [USB Billboard Device Class](#) interface with updated capabilities.

5.1.4.3 Operational Summary

The following summarizes the basic process of discovery through configuration when the USB/PCIe Dock is attached to the Host.

1. Host detects presence of a device (CC pins) and connector orientation
2. Host applies default VBUS
3. Host applies VCONN because the dock presents [Ra](#)
4. Host uses [USB PD](#) to make power contract with the Dock device

5. Host runs the Discover Identify process
 - a. Sends Discover Identity message
 - b. Receives an ACK message with information identifying the cable
6. Host runs the Discover SVIDs process
 - a. Sends Discover SVID message
 - b. Receives an ACK message with list of SVIDs for which the Dock device has modes
7. Host runs the Discover Modes process
 - a. Sends Discover Modes VDM for the VIDs previously discovered
 - b. Receives an ACK message with a list of modes associated with each VID
 - c. If USB/PCIe Dock mode not found – fall out and enumerate USB bus for the [USB Billboard Device Class](#) interface and inform the user of the error - done
 - d. Else
8. Host runs the Enter Mode process
 - a. Sends Enter Mode VDM with VID and USB/PCIe Dock mode
 - b. Receives an ACK message – Host is now attached to the USB/PCIe Dock and supports PCIe signaling to interface additional functions in combination with USB signaling
9. Host stays in the USB/PCIe Dock mode until
 - a. Explicitly exited by an Exit Mode VDM
 - b. System physically removed from the USB/PCIe Dock
 - c. Hard Reset on [USB PD](#)
 - d. VBUS is removed

5.2 Managed Active Cables

Active cables that require configuration (managed active cable) shall use [USB Power Delivery](#) Structured VDMs to discover and configure the cable.

[USB Power Delivery](#) Structured VDMs provide a standardized mechanism for identifying and managing the functionality of active cables.

Some managed active cables only have a single [USB PD](#) controller in the cable that responds to [USB PD](#) Structured VDMs sent to SOP'.

When a managed active cable requires independent management at each end of the cable, separate [USB PD](#) controllers responding to [USB PD](#) Structured VDMs sent to SOP' and SOP'' can be located in each plug.

5.2.1 Requirements for Managed Active Cables that respond to SOP' and SOP''

After a power-on reset event or a [USB PD](#) Hard Reset, the [USB PD](#) controller attached to the DFP is assigned SOP' and the [USB PD](#) controller attached to the UFP is assigned SOP''. After a [USB PD](#) Cable Reset, the plug being supplied VCONN responds to SOP' independent of whether it is the plug attached to the DFP or UFP. The controllers can sense whether they are SOP' or SOP'' based on the presence of VCONN at the plug's VCONN pin as only one port supplies VCONN.

Figure 5-4 illustrates the process that shall be followed to assign SOP' and SOP'' to the ends attached to the DFP and UFP, respectively, at power on. In the Unassigned state, the active cable will not respond to any [USB PD](#) communication sent to SOP' or SOP''. The parameter [tVCONNStable](#) allows time for the active cable to set up to communicate.

Figure 5-4 Managed Active Cable Plug SOP' and SOP'' Assignment

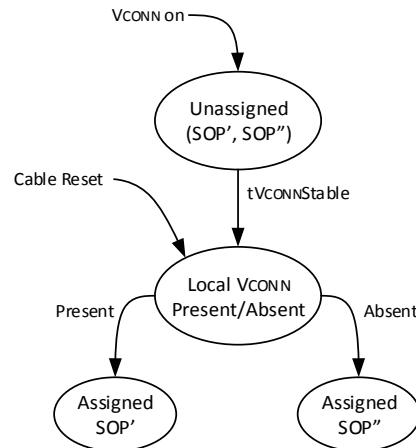

When VCONN is removed, the plug's local VCONN shall discharge to below its SOP' detection threshold within 20 ms.

A managed active cable shall assure that the two [USB PD](#) controllers are uniquely assigned via the mechanism described here, one as SOP' and the other as SOP''.

[USB PD](#) supports three types of USB Type-C-related swaps that may or may not impact VCONN:

- [USB PD](#) VCONN_Swap – The port previously not supplying VCONN sources VCONN and the assignment of SOP' and SOP'' remain unchanged.
- [USB PD](#) DR_Swap – The assignment of SOP' and SOP'' remain unchanged.
- [USB PD](#) PR_Swap – The assignment of SOP' and SOP'' remain unchanged.

Managed active USB Type-C to USB Type-C cables shall by default support USB operation. Multi-modal cables (e.g., an active cable that supports an [Alternate Mode](#) in addition to USB SuperSpeed) that use the TX/RX signal pairs shall minimally support [USB 3.1](#) Gen 1 operation. They are encouraged to support both Gen 1 and Gen 2 operation.

Figure 5-5 illustrates a typical managed active cable. The isolation elements (Iso) shall prevent VCONN from traversing end-to-end through the cable. [Ra](#) is required in the cable to allow the DFP to determine that VCONN is needed.

Figure 5-5 Managed Active Cable

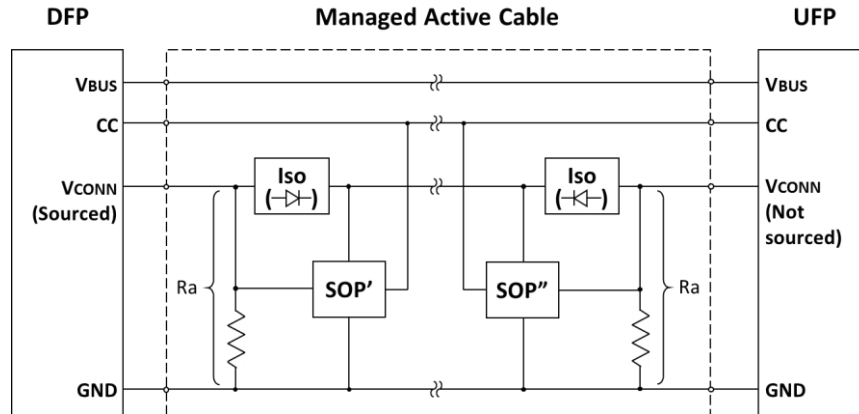

5.2.1.1 Parameter Values

Table 5-2 provides the power on timing requirements for SOP' and SOP'' to be ready to communicate.

Table 5-4 SOP' and SOP'' Timing

	Maximum	Description
tVCONNStable	100 ms	The time between the application of VCONN until SOP' and SOP'' shall be ready for communication.

5.2.2 Cable Message Structure

[USB PD](#) Structured VDMs shall be used to identify and manage active cables. Cables that require additional functionality, for example to program parameters in the active electronics, may define proprietary Structured VDMs to provide the necessary functionality. In all cases, these messages shall only use SOP' and SOP''. They shall not use SOP.

SOP' and SOP'' are defined to allow a vendor to communicate individually with each end the cable. With one exception, only the DFP shall be allowed to communicate with SOP' and SOP'' after an explicit [USB PD](#) contract has been entered. The exception is when a UFP has confirmed that it is communicating with a [USB PD](#) BFSK-based source and needs to communicate with SOP' to identify if the cable is capable of greater than 1.5 A.

For active cables that support both SOP' and SOP'', after attach or a [USB PD](#) Cable Reset, the plug directly connected to the DFP shall only respond to SOP' and the plug directly connected to the UFP shall only respond to SOP''.

The assignment of SOP' and SOP'' to each plug remains persistent until VCONN is removed or a subsequent [USB PD](#) Cable Reset.

The Discover Identity message shall start with SOP'.

5.2.3 Modal Cable Management

In addition to supporting the Discover Identity message, managed active cables shall support the following [USB Power Delivery](#) Structured VDMs. These VDMs shall start with SOP'.

5.2.3.1 Discover SVIDs

The managed active cable shall return a list of SVIDs that it supports.

5.2.3.2 Discover Modes

The managed active cable shall return a list of [Alternate Modes](#) it supports for each SVID.

5.2.3.3 Enter Mode

The managed active cable shall use the Enter Mode command to enter an [Alternate Mode](#). The behavior of the cable following Enter Mode is vendor specific.

5.2.3.4 Exit Mode

The managed active cable shall use the Exit Mode command to exit an [Alternate Mode](#) previously entered. Exit Mode shall return the cable to its default USB operation.

A Audio Adapter Accessory Mode

A.1. Overview

Analog audio headsets are supported by multiplexing four analog audio signals onto pins on the USB Type-C connector when in the Audio Adapter Accessory Mode. The four analog audio signals are the same as those used by a traditional 3.5 mm headset jack. This makes it possible to use existing analog headsets with a 3.5 mm to USB Type-C adapter. The audio adapter architecture allows for an audio peripheral to provide up to 500 mA back to the system for charging.

An analog audio adapter could be a very basic USB Type-C adapter that only has a 3.5 mm jack or it could be an analog audio adapter with a 3.5 mm jack and a USB Type-C receptacle to enable charge-through. It could also be a headset that replaces its 3.5 mm plug with a USB Type-C plug.

A.2. Detail

An analog audio adapter shall use a captive cable with a USB Type-C plug or include an integrated USB Type-C plug.

The analog audio adapter shall identify itself by presenting a resistance to GND of $\leq R_a$ on both A5 (CC) and B5 (VCONN) of the USB Type-C plug. If pins A5 and B5 are shorted together, the effective resistance to GND shall be less than $R_a/2$.

A DFP that supports analog audio adapters shall detect the presence of an analog audio adapter by detecting a resistance to GND of less than R_a on both A5 (CC) and B5 (VCONN).

Table A-1 shows the pin assignments at the USB Type-C plug that shall be used to support analog audio.

Table A-1 USB Type-C Analog Audio Pin Assignments

Plug Pin	USB Name	Analog Audio Function	Location on 3.5 mm Jack	Notes
A5	CC			Connected to digital GND with resistance $\leq R_a$. System uses for presence detect.
B5	VCONN			Connected to digital GND with resistance $\leq R_a$. System uses for presence detect.
A6/B6	Dp	Right	Ring 1	Analog audio right channel A6 and B6 may be shorted together in the adapter.
A7/B7	Dn	Left	Tip	Analog audio left channel A7 and B7 may be shorted together in the adapter.
A8	SBU1	Mic/AGND	Ring 2	Analog audio microphone (OMTP & YD/T) or Audio GND (CTIA).
B8	SBU2	AGND/Mic	Sleeve	Audio GND (OMTP & YD/T or analog audio microphone (CTIA).
A1/A12 B1/B12	GND			Digital GND (DGND) used as the ground reference and current return for CC1, CC2, and VBUS.
A4/A9 B4/B9	VBUS			Not connected unless the audio adapter uses this connection to provide 5 V @ 500 mA for charging the system's battery.
Others				Other pins shall not be connected.

The analog audio signaling presented by the headset on the 3.5 mm jack is expected to comply with at least one of the following:

- The traditional American headset jack pin assignment, with the jack sleeve used for the microphone signal, supported by CTIA-The Wireless Association
- “Local Connectivity: Wired Analogue Audio” from the Open Mobile Terminal Forum (OMTP) forum
- “Technical Requirements and Test Methods for Wired Headset Interface of Mobile Communication Terminal” (YT/D 1885-2009) from the China Communications Standards Association

When in the Audio Adapter Accessory Mode, the system shall not provide VCONN power on either CC1 or CC2. Failure to do this may result in VCONN being shorted to GND when an analog audio peripheral is present.

The system shall connect A6/B6, A7/B7, A8 and B8 to an appropriate audio codec upon entry into the Audio Adapter Accessory Mode. The connections for A8 (SBU1) and B8 (SBU2) pins are dependent on the adapter's orientation. Depending on the orientation, the microphone and analog ground pins may be swapped. These pins are already reversed between the two major standards for headset jacks and support for this is built into the headset connection of many codecs or can be implemented using an autonomous audio headset switch. The system shall work correctly with either configuration.

A.3. Electrical Requirements

The maximum ratings for pin voltages are referenced to GND (pins A1, A12, B1, and B12). The non-GND pins on the plug shall be isolated from GND on the USB Type-C connector and shall be isolated from the USB plug shell. To minimize the possibility of ground loops

between systems, AGND shall be connected to GND only within the system containing the USB Type-C receptacle. Both the system and audio device implementations shall be able to tolerate the Right, Left, Mic, and AGND signals being shorted to GND. The current provided by the amplifier driving the Right and Left signals shall not exceed ± 150 mA per audio channel, even when driving a 0Ω load.

Table A-2 shows allowable voltage ranges on the pins in the USB Type-C plug that shall be met.

Table A-2 USB Type-C Analog Audio Pin Electrical Parameter Ratings

Plug Pin	USB Name	Analog Audio Function	Min	Max	Units	Notes
A6/B6	Dp	Right	-3.0	3.0	V	A6 and B6 may be shorted together in the analog audio adapter
A7/B7	Dn	Left	-3.0	3.0	V	A7 and B7 may be shorted together in the analog audio adapter
A8	SBU1	Mic/AGND	-0.4	3.3	V	
B8	SBU2	AGND/Mic	-0.4	3.3	V	

The maximum voltage ratings for Left and Right signals are selected to encompass a 2 Vrms sine wave ($2.828 V_p = 5.657 V_{pp} = 6$ dBV) which is a common full-scale voltage for headset audio output.

Headset microphones operate on a positive bias voltage provided by the system's audio codec and AC-couple the audio signal onto it. Some headsets may produce an audio signal level up to 0.5 Vrms ($0.707 V_p = 1.414 V_{pp} = -6$ dBV) but this is biased so that the voltage does not swing below GND. The bias voltage during operation is typically around 1.25 V but it varies quite a bit depending on the specifics of the manufacturer's design, therefore the maximum voltage rating for the SBU pins is selected to allow a variety of existing solutions.

While one SBU pin carries the Mic signal, the other SBU pin serves as AGND carrying the return current for Left, Right, and Mic. If we assume a worst-case headset speaker impedance of 16Ω per speaker, then the worst-case return current for the speakers is ± 0.2 A. If we assume that the worst-case resistance from the AGND pin to GND within the USB Type-C system is 1Ω (due to FET R_{ON} within the signal multiplexer, contact, and trace resistances), then the voltage of the AGND pin with respect to USB Type-C GND can vary between ± 0.2 V. The minimum voltage rating for the SBU pins has been selected to allow for this scenario with some additional margin to account for Mic signal return current and tolerances.

The system shall exhibit no more than -48 dB linear crosstalk between the Left and Right audio channels and exhibit no more than -51 dB linear crosstalk from the Left or Right channel to the Mic channel. Crosstalk measurements shall be made using a measurement adapter plug that supports USB Type-C analog audio connections according to Table A-1. In the measurement adapter, the Left and Right channels are terminated with 32Ω resistors to AGND, the Mic channel is terminated with $2k \Omega$ resistor to AGND; AGND is connected to USB Type-C Plug Pin A8, and the Mic channel is connected to USB Type-C Plug Pin B8.

Crosstalk shall be measured by using the system to drive a sine wave signal to the Left output channel and zero signal to the Right output channel. The system shall configure the Mic channel according to the default Mic operating mode supported by the system. AC voltage levels at the Left, Right and Mic channels are measured across the corresponding termination resistors using a third-octave filter at the sine signal frequency. Left - Right

crosstalk is reported as ratio of the Right channel voltage to the Left channel voltage expressed in decibels. Similarly, the Left – Mic crosstalk is reported. The measurements shall be conducted at 31.5, 63, 125, 250, 500, 1000, 2000, 4000, 8000 and 16000 Hz frequencies. The measurements shall be repeated so that the sine wave signal is driven to the Right channel and Right – Left and Right – Mic crosstalk results are obtained. Both USB Type-C plug orientations shall be measured.”

A.4. Example Implementations

A.4.1. Passive 3.5 mm to USB Type-C Adapter – Single Pole Detection Switch

Figure A-1 illustrates how a simple 3.5 mm analog audio adapter can be made. In this design, there is an audio plug that contains a single-pole detection switch that is used to completely disconnect the CC and VCONN pins from digital GND when no 3.5 mm plug is inserted. This has the effect of triggering the USB Type-C presence detect logic upon insertion or removal of either the 3.5 mm plug or the audio adapter itself.

Figure A-1 Example Passive 3.5 mm to USB Type-C Adapter

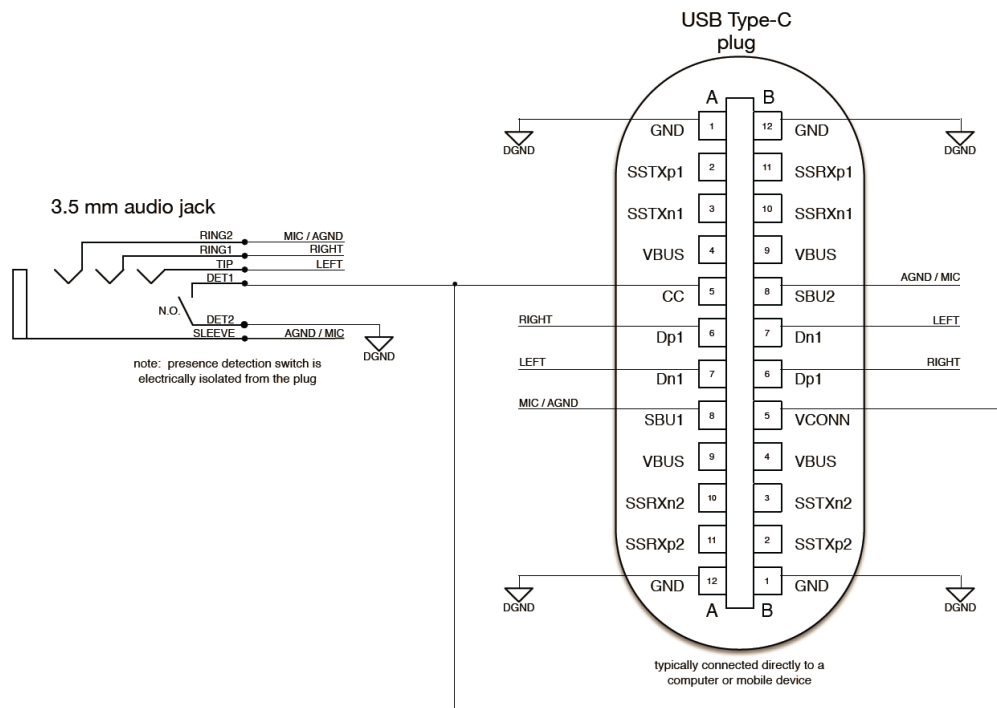

A.4.2. 3.5 mm to USB Type-C Adapter Supporting 500 mA Charge-Through

Figure A-2 illustrates a 3.5 mm analog audio adapter that supports charge-through operation. Charging power comes into the adapter through a USB Type-C receptacle and is routed directly to the adapter’s USB Type-C plug, which is plugged into the device being charged. This design is limited to providing 500 mA of charge-through current since it has no way to advertise greater current-sourcing capability. The USB Type-C receptacle presents Rd on both of its CC pins because a CC pull-down must be present for the receptacle to indicate that it wants to consume VBUS current. USB Type-C systems that support analog audio should ensure that charging is not interrupted by insertion or removal of the 3.5 mm audio plug and that audio is not interrupted by insertion or removal of the cable connected

to the audio adapter's USB Type-C receptacle by using the system's presence detection logic monitoring the states of both CC pins and VBUS.

Figure A-2 Example 3.5 mm to USB Type-C Adapter Supporting 500 mA Charge-Through

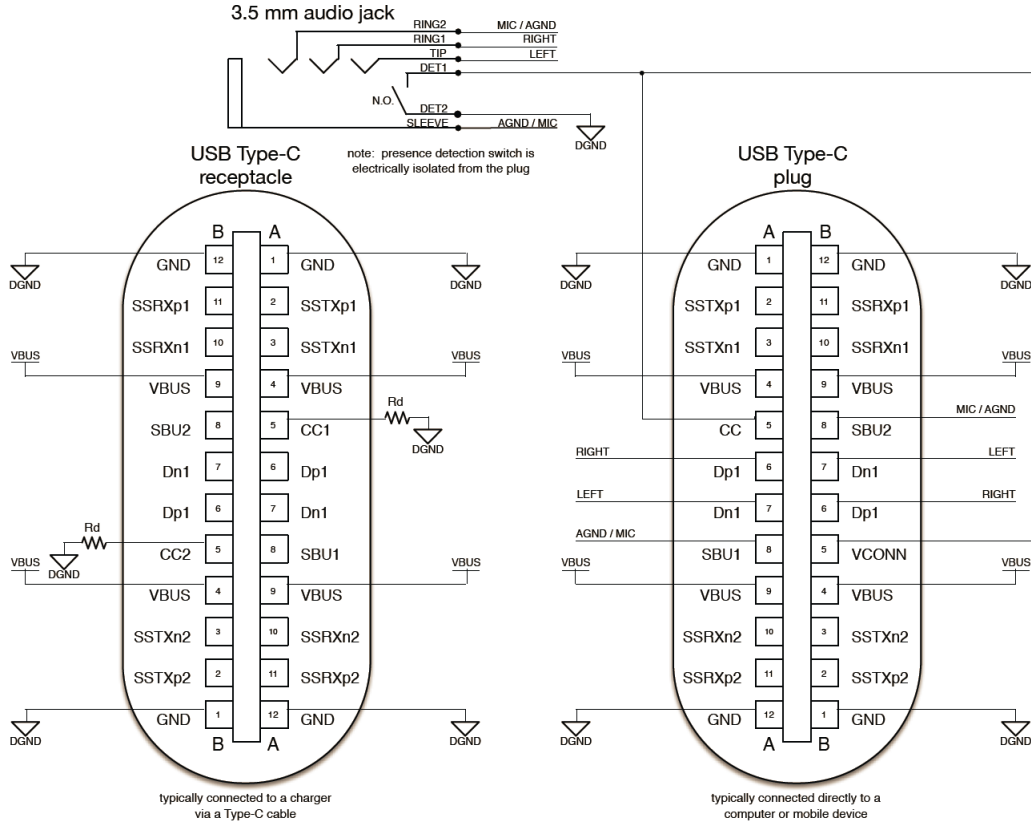

B Debug Accessory Mode

This appendix is reserved for the future definition of the Debug Accessory Mode.